



OPERATOR'S AND PARTS MANUAL

COMPACT TRACTOR PALLET FORK



PALADIN™
LIGHT CONSTRUCTION GROUP

 **BRADCO**

 **FFC**

 **HARLEY**

 **MCMILLEN**

 **SWEEPSTER**

The Power of Combined Excellence

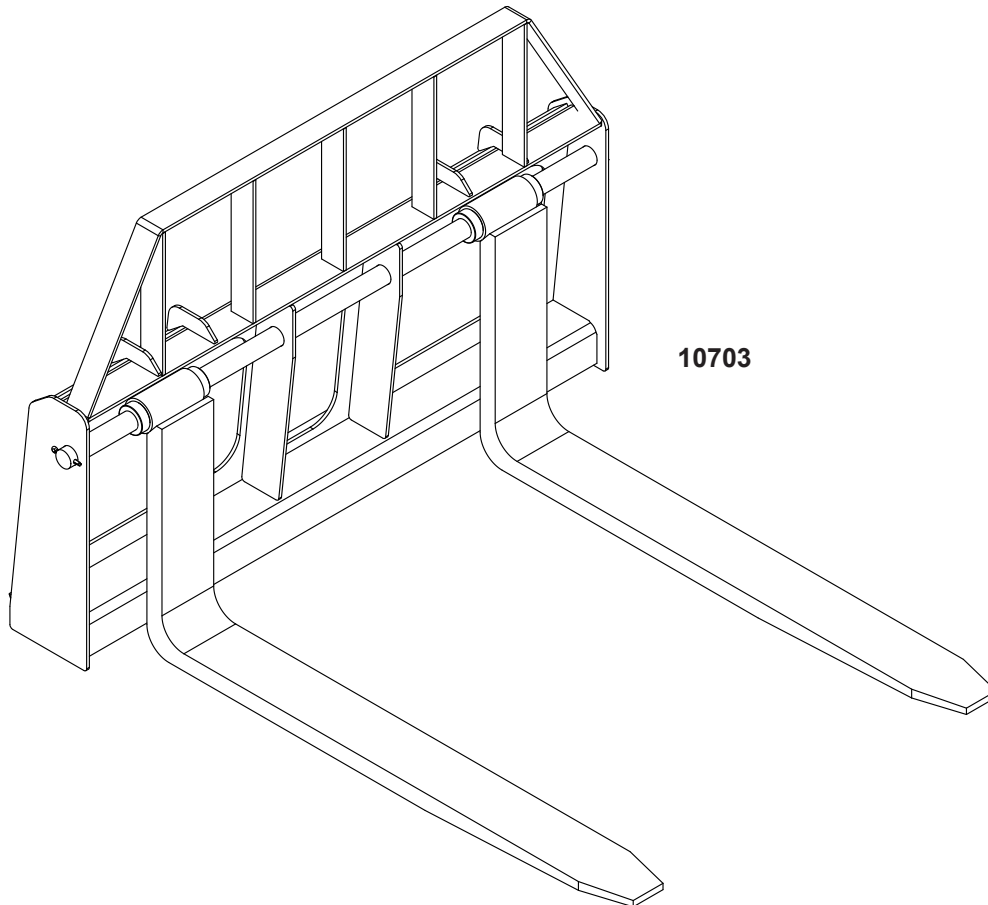

SERIAL NUMBER: _____

MODEL NUMBER: _____

Manual Number: 51-10033
Part Number: 10703 & 10743
Rev. 2

TABLE OF CONTENTS

INTRODUCTION	2
GENERAL INFORMATION	2
SERIAL NUMBER	2
OWNER AND OPERATOR SAFETY INFORMATION	
SAFETY STATEMENTS	3
SAFETY PRECAUTIONS	3-5
SAFETY SIGNS	6-7
SPECIFICATIONS	8-9
MOUNTING	10
OPERATION	11
MAINTENANCE	12
SERVICE	13
10703 & 10743 PARTS ILLUSTRATION & LIST	14
WARRANTY	i

INTRODUCTION

Congratulations on your purchase of a new FFC Compact Tractor Pallet Fork. This product has been designed and built to lift stable objects vertically. You or any other person who will be assembling, operating, maintaining, or working with this product are required to read and completely understand the information and instructions contained in this manual. If anyone does not fully understand every part of this manual, please obtain further assistance by contacting the dealer from which this product was purchased or by contacting FFC at the telephone number or address listed on the cover of this manual. Keep this manual available for reference whenever this product is being handled or used. Provide this manual to any new owners and/or operators. This manual covers model(s) 10703 and 10743.

GENERAL INFORMATION

The purpose of this manual is to assist in assembling, mounting, operating, and maintaining your attachment. Read this manual carefully to obtain valuable information and instructions that will help you achieve years of safe and dependable service.

The illustrations and data used in this manual were current at the time of printing, but due to possible engineering and/or production changes, this product may vary slightly in detail. FFC reserves the right to redesign and/or change components as may be necessary without notification to anyone. Throughout this manual, references may be made to:

Tractor	The engine-driven machine to which this product must be attached.
Right, Left, Front, Rear	Directions that are determined in relation to the operator of the equipment when seated in the normal operation position.
IMPORTANT	Precautions that must be followed to prevent substandard performance.

SERIAL NUMBER LOCATION

Always refer to the model and serial number when ordering parts or requesting information from your dealer. See Safety Signs section for the location of the serial number plate for this product.

Reference Information	
Model Number	Tractor Make & Model
Serial Number	Loader Model
Date Purchased	Loader Serial Number

SAFETY STATEMENTS



THIS SYMBOL BY ITSELF OR WITH A WARNING WORD THROUGHOUT THIS MANUAL IS USED TO CALL YOUR ATTENTION TO INSTRUCTIONS INVOLVING YOUR PERSONAL SAFETY OR THE SAFETY OF OTHERS. FAILURE TO FOLLOW THESE INSTRUCTIONS CAN RESULT IN INJURY OR DEATH.



DANGER

THIS SIGNAL WORD IS USED WHERE SERIOUS INJURY OR DEATH WILL RESULT IF THE INSTRUCTIONS ARE NOT FOLLOWED PROPERLY.



WARNING

THIS SIGNAL WORD IS USED WHERE SERIOUS INJURY OR DEATH COULD RESULT IF THE INSTRUCTIONS ARE NOT FOLLOWED PROPERLY.



CAUTION

THIS SIGNAL WORD IS USED WHERE MINOR INJURY COULD RESULT IF THE INSTRUCTIONS ARE NOT FOLLOWED PROPERLY.

NOTICE

NOTICE INDICATES A PROPERTY DAMAGE MESSAGE.

GENERAL SAFETY PRECAUTIONS

WARNING! READ MANUAL PRIOR TO INSTALLATION



Improper installation, operation, or maintenance of this equipment could result in serious injury or death. Operators and maintenance personnel should read this manual, as well as all manuals related to this equipment and the tractor thoroughly before beginning installation, operation, or maintenance. **FOLLOW ALL SAFETY INSTRUCTIONS IN THIS MANUAL AND THE TRACTOR'S MANUAL(S).**



READ AND UNDERSTAND ALL SAFETY STATEMENTS

Read all safety decals and safety statements in all manuals prior to operating or working on this equipment. Know and obey all OSHA regulations, local laws, and other professional guidelines for your operation. Know and follow good work practices when assembling, maintaining, repairing, mounting, removing, or operating this equipment.



KNOW YOUR EQUIPMENT

Know your equipment's capabilities, dimensions and operations before operating. Visually inspect your equipment before you start, and never operate equipment that is not in proper working order with all safety devices intact. Check all hardware to ensure it is tight. Make certain that all locking pins, latches, and connection devices are properly installed and secured. Remove and replace any damaged, fatigued, or excessively worn parts. Make certain all safety decals are in place and are legible. Keep decals clean, and replace them if they become worn and hard to read.

GENERAL SAFETY PRECAUTIONS

WARNING! PROTECT AGAINST FLYING DEBRIS



Always wear proper safety glasses, goggles or a face shield when driving pins in or out, or when any operation causes dust, flying debris, or any other hazardous material.

WARNING! LOWER OR SUPPORT RAISED EQUIPMENT



Do not work under raised booms without supporting them. Do not use support material made of concrete blocks, logs, buckets, barrels or any other material that could suddenly collapse or shift positions. Make sure support material is solid, not decayed, warped, twisted, or tapered. Lower booms to ground level or onto blocks. Lower booms and attachments to the ground before leaving the cab or operator's station.

WARNING! USE CARE WITH HYDRAULIC FLUID PRESSURE



Hydraulic fluid under pressure can penetrate the skin and cause serious injury or death. Hydraulic leaks under pressure may not be visible. Before connecting or disconnecting hydraulic hoses, read your tractor's operator's manual for detailed instructions on connecting and disconnecting hydraulic hoses or fittings.

- Keep unprotected body parts, such as face, eyes, and arms as far away as possible from a suspected leak. Flesh injected with hydraulic fluid may develop gangrene or other permanent disabilities.
- If injured by injected fluid, see a doctor at once. If your doctor is not familiar with this type of injury, ask him to research immediately to determine proper treatment.
- Wear safety glasses, protective clothing, and use a sound piece of cardboard or wood when searching for hydraulic leaks. **DO NOT USE YOUR HANDS!** **SEE ILLUSTRATION.**

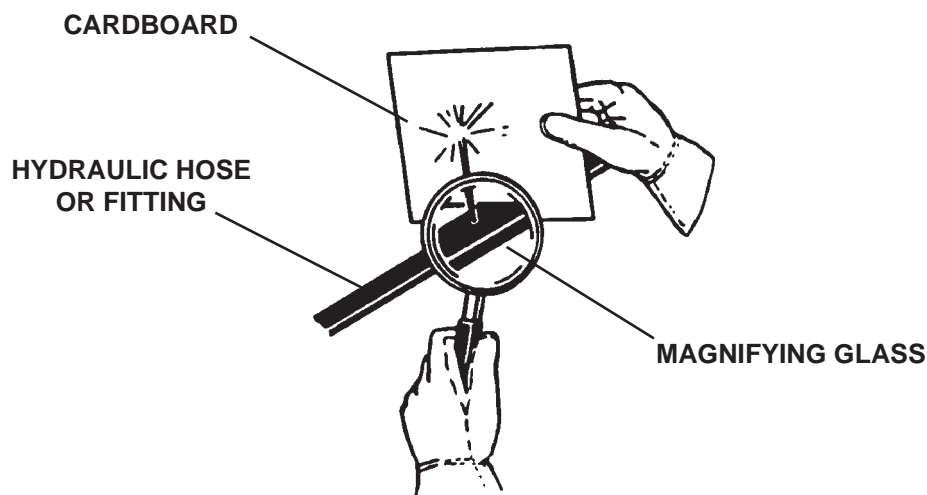

GENERAL SAFETY PRECAUTIONS

WARNING! DO NOT MODIFY MACHINE OR ATTACHMENTS



Modifications may weaken the integrity of the attachment and may impair the function, safety, life, and performance of the attachment. When making repairs, use only the manufacturer's genuine parts, following authorized instructions. Other parts may be substandard in fit and quality. Never modify any ROPS (Roll Over Protection Structure) or FOPS (Falling Object Protective Structure) equipment or device. Any modifications must be authorized in writing by the manufacturer.

WARNING! SAFELY MAINTAIN AND REPAIR EQUIPMENT



- Do not wear loose clothing, or any accessories that can catch in moving parts. If you have long hair, cover or secure it so that it does not become entangled in the equipment.
- Work on a level surface in a well-lit area.
- Use properly grounded electrical outlets and tools.
- Use the correct tool for the job at hand. Make sure they are in good condition for the task required.
- Wear the protective equipment specified by the tool manufacturer.

WARNING! SAFELY OPERATE EQUIPMENT



Do not operate equipment until you are completely trained by a qualified operator in how to use the controls, know its capabilities, dimensions, and all safety requirements. See your machine's manual for these instructions.

- Keep all step plates, grab bars, pedals, and controls free of dirt, grease, debris, and oil.
- Never allow anyone to be around the equipment when it is operating.
- Do not allow riders on the attachment or the tractor.
- Do not operate the equipment from anywhere other than the correct operators position.
- Never leave equipment unattended with the engine running or with this attachment in a raised position.
- Do not alter or remove any safety feature from the tractor or this attachment.
- Know your work site safety rules as well as traffic rules and flow. When in doubt on any safety issue, contact your supervisor or safety coordinator for an explanation.

WARNING! KNOW WHERE UTILITIES ARE



Observe overhead electrical and other utility lines. Be sure equipment will clear them. When digging, call your local utilities for location of buried utility lines, gas, water, and sewer, as well as any other hazard you may encounter.

SAFETY SIGN LOCATIONS

The diagrams on this page show the location of the decals used on the FFC Pallet Forks. The decals are identified by their part numbers, with reductions of the actual decals located on the following page. Use this information to order replacements for lost or damaged decals. Be sure to read all decals before operating the attachment. They contain information you need to know for both safety and product longevity.

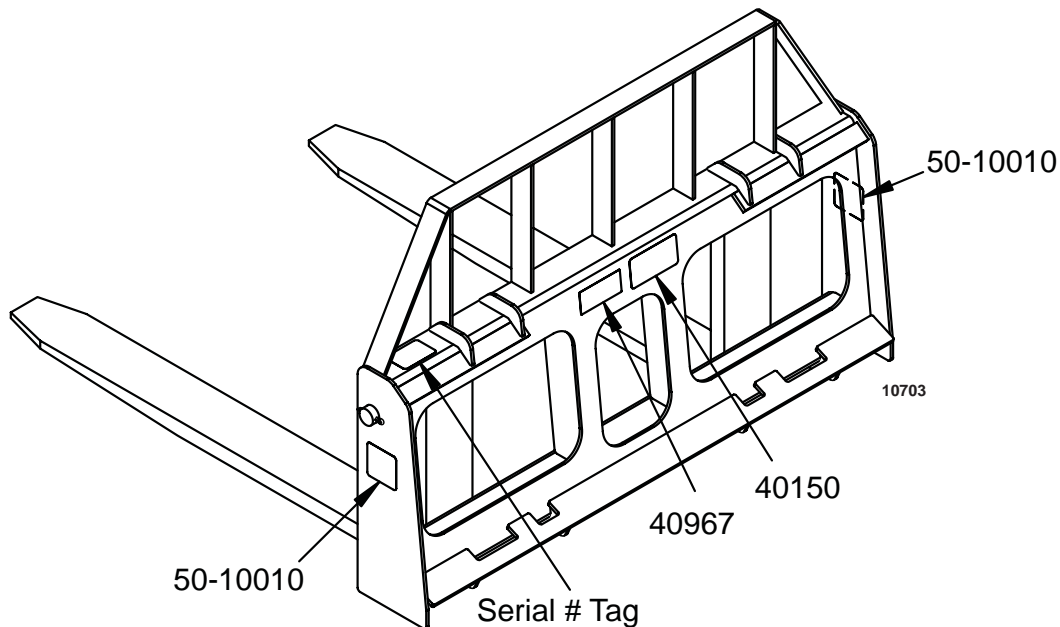

INSTRUCTIONS

- Keep all safety signs clean and legible.
- Replace all missing, illegible, or damaged safety signs.
- Replacement parts for parts with safety signs attached must also have safety signs attached.
- Safety signs are available, free of charge, from your dealer or from FFC.

PLACEMENT OR REPLACEMENT OF SAFETY SIGNS

1. Clean the area of application with non-flammable solvent, and then wash the same area with soap and water.
2. Allow the surface to fully dry.
3. Remove the backing from the safety sign, exposing the adhesive surface.
4. Apply the safety sign to the position shown in the diagram above and smooth out any bubbles.

SAFETY SIGNS

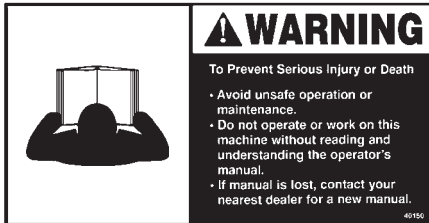

PART #40150
WARNING! READ MANUAL



PART #40967
WARNING! SPECIFICATIONS



PART #50-10010
CAUTION! DO NOT DETACH LOADER

TRACTOR/LOADER SPECIFICATIONS

IMPORTANT Exceeding any of the maximum recommended tractor/loader specifications **CAN** result in damage to this product and **WILL** void all FFC warranties.

DESCRIPTION	SPECIFICATIONS	
	10703	10743
Tractor HP	40 HP maximum	80 HP maximum
Operating Weight of Tractor	4,000 lbs. maximum	8,000 lbs. maximum
Lift Capacity of Tractor's Loader	2,000 lbs. maximum	4,000 lbs. maximum
Rear Ballast	As required to maintain full tractor stability. (Note the shipping weight of your model, then see the operator's manual(s) for your tractor and loader for ballasting needs.)	

ATTACHMENT SPECIFICATIONS

Model Number	Overall Width	Overall Height	Overall Depth	Shipping Weight
10703-42	47-5/8"	31"	51"	335#
10703-48	47-5/8"	31"	57"	355#
10743-42	47-5/8"	31"	51"	420#
10743-48	47-5/8"	31"	57"	445#

BOLT TORQUE



BOLT TORQUE SPECIFICATIONS

GENERAL TORQUE SPECIFICATION TABLES

Use the following charts when determining bolt torque specifications when special torques are not given. Always use grade 5 or better when replacing bolts.



SAE BOLT TORQUE SPECIFICATIONS

NOTE: The following torque values are for use with extreme pressure lubricants, plating or hard washer applications. Increase torque 15% when using hardware that is unplated and either dry or lubricated with engine oil.

Bolt Size		SAE GRADE 5 TORQUE				SAE GRADE 8 TORQUE				Bolt head identification marks as per grade. NOTE: Manufacturing Marks Will Vary
		Pounds Feet		Newton-Meters		Pounds Feet		Newton-Meters		
Inches	Millimeters	UNC	UNF	UNC	UNF	UNC	UNF	UNC	UNF	
1/4	6.35	8	9	11	12	10	13	14	18	<div style="text-align: center;"> <p>GRADE 2</p>  <p>GRADE 5</p>  <p>GRADE 8</p>  </div>
5/16	7.94	14	19	19	23	20	25	27	34	
3/8	9.53	30	36	41	49	38	46	52	62	
7/16	11.11	46	54	62	73	60	71	81	96	
1/2	12.70	68	82	92	111	94	112	127	152	
9/16	14.29	94	112	127	152	136	163	184	221	
5/8	15.88	128	153	174	207	187	224	254	304	
3/4	19.05	230	275	312	373	323	395	438	536	
7/8	22.23	340	408	461	553	510	612	691	830	
1	25.40	493	592	668	803	765	918	1037	1245	
1-1/8	25.58	680	748	922	1014	1088	1224	1475	1660	
1-1/4	31.75	952	1054	1291	1429	1547	1700	2097	2305	
1-3/8	34.93	1241	1428	1683	1936	2023	2312	2743	3135	
1-1/2	38.10	1649	1870	2236	2535	2686	3026	3642	4103	

METRIC BOLT TORQUE SPECIFICATIONS

NOTE: The following torque values are for use with metric hardware that is unplated and either dry or lubricated with engine oil. Reduce torque 15% when using hardware that has extreme pressure lubricants, plating or hard washer applications.

Bolt head identification marks as per grade.		
		

Size of Bolt	Grade No.	Pitch (mm)	Pounds Feet	Newton-Meters	Pitch (mm)	Pounds Feet	Newton-Meters
M6	5.6	1.0	3.6-5.8	4.9-7.9	-	-	-
	8.8		5.8-4	7.9-12.7		-	-
	10.9		7.2-10	9.8-13.6		-	-
M8	5.6	1.25	7.2-14	9.8-19	1.0	12-17	16.3-23
	8.8		17-22	23-29.8		19-27	25.7-36.6
	10.9		20-26	27.1-35.2		22-31	29.8-42
M10	5.6	1.5	20-25	27.1-33.9	1.25	20-29	27.1-39.3
	8.8		34-40	46.1-54.2		35-47	47.4-63.7
	10.9		38-46	51.5-62.3		40-52	54.2-70.5
M12	5.6	1.75	28-34	37.9-46.1	1.25	31-41	42-55.6
	8.8		51-59	69.1-79.9		56-68	75.9-92.1
	10.9		57-66	77.2-89.4		62-75	84-101.6
M14	5.6	2.0	49-56	66.4-75.9	1.5	52-64	70.5-86.7
	8.8		81-93	109.8-126		90-106	122-143.6
	10.9		96-109	130.1-147.7		107-124	145-168
M16	5.6	2.0	67-77	90.8-104.3	1.5	69-83	93.5-112.5
	8.8		116-130	157.2-176.2		120-138	162.6-187
	10.9		129-145	174.8-196.5		140-158	189.7-214.1
M18	5.6	2.0	88-100	119.2-136	1.5	100-117	136-158.5
	8.8		150-168	203.3-227.6		177-199	239.8-269.6
	10.9		175-194	237.1-262.9		202-231	273.7-313
	5.6		108-130	146.3-176.2		132-150	178.9-203.3

MOUNTING

WARNING! READ MANUAL PRIOR TO INSTALLATION



Improper installation, operation, or maintenance of this equipment could result in serious injury or death. Operators and maintenance personnel should read this manual, as well as all manuals related to this equipment and the tractor/loader thoroughly before beginning installation, operation, or maintenance. **FOLLOW ALL SAFETY INSTRUCTIONS IN THIS MANUAL AND THE TRACTOR'S MANUAL(S).**

1. Place this product on a firm, level surface that is large enough to safely accommodate this product, your tractor/loader and all workers involved in the mounting process.
2. Refer to the operator's manual(s) for your tractor and loader. Follow the mounting instructions contained therein.
3. Carefully raise the loader and cycle the tilt cylinders to check clearances and to verify that all mounting procedures have been successfully completed.

ADJUSTING THE FORK TINES

With the loader arms lowered and completely rolled back, shut down the prime mover, set the parking brake and remove the key. (If tines are still in contact with the ground the loader arms may need to be raised just enough to eliminate contact.)

FLOATING FORK TINES (10703 & 10743 Pallet Fork): Loosen the set screws on the set collars and slide the tines into the desired position making sure that the left and right tine are the same distance from the center of the frame. Tighten set screws to secure the tines in place.

WARNING! Never exceed the recommended lifting capacity of any approved fork tines or the prime mover.



NOTE: Fork tine capacities are pounds per pair at a 24" load center. (The center of gravity of the allowable loads must be applied within the first 24" of the fork tines when measured from the front face of the vertical section of the fork tine out toward the tip of the horizontal section of the fork tine.)

OPERATION

**Read all Safety Precautions before operating your new attachment.
Refer to your machines operator's manual for attachment operation.**

The pallet fork was designed to lift stable objects vertically. There are two different pallet fork frames (floating) available along with two different length fork tines (42" and 48"). The 10703 floating tines have a load rating of 3750 lbs and the 10743 floating tines have a load rating of 5500 lbs.

1. Approach the load in such a fashion that the weight will be centered between the fork tines. The heaviest side should be closest to the fork frame and not near the tips of the fork tines.
2. Before lifting make certain the fork tines are completely under the load and level.
3. Lift the load slightly to make sure the load is stable. If load appears unstable, lower and reposition the tines to achieve full stability.
4. Raise the load to the MINIMUM height required for the terrain.
5. During material handling; keep the fork tines level, stop and start loader gradually, slow down before turning and avoid any obstacles, bumps or holes.
6. Check load frequently to ensure stability.



**Operate the attachment only when properly seated at the operator's station.
Any other method could result in serious personal injury or death.**

Do not exceed the recommended lifting capacity of any approved fork tines or the prime mover. Keep lifting surface of the forks level at all times. Do not use the fork tines for prying or any purpose other than lifting.

Do not lift round or square bales.

Reduce speed when driving over rough terrain, on a slope, or turning, to avoid overturning the vehicle.

Secure the load properly. Unsecured loads can fall unexpectedly. When handling a load, keep the forks as close to the ground as possible.

Before exiting the prime mover, lower the pallet fork to the ground, turn off the prime mover's engine, remove the key and apply the brakes.

Do not detach loader from tractor with the attachment installed. Equip loader with materials bucket when detaching.

MAINTENANCE



KNOW YOUR EQUIPMENT

Know your equipment's capabilities, dimensions and operations before operating. Visually inspect your equipment before you start, and never operate equipment that is not in proper working order with all safety devices intact. Check all hardware to ensure it is tight. Make certain that all locking pins, latches, and connection devices are properly installed and secured. Remove and replace any damaged, fatigued, or excessively worn parts. Make certain all safety decals are in place and are legible. Keep decals clean, and replace them if they become worn and hard to read.

BEFORE EACH USE

- Make sure that all nuts and bolts are in place and properly tightened.
- Make sure that all other fasteners are in place and are performing their specified function.
- Make sure that all safety signs are in place, are clean, and are legible.
- Replace any damaged parts and excessively worn parts.

IMPORTANT: When replacing parts, use only factory approved replacement parts. Manufacturer will not claim responsibility for use of unapproved parts or accessories and/or other damages as a result of their use.

MONTHLY OR EVERY 40 HOURS OF OPERATION

- Check all bolts, nuts and bearings for tightness. Tighten or replace as needed.
- Clean equipment of dirt, oil, grease, etc. This will assist you in making a visual inspection and help avoid overlooking worn or damaged components.

SERVICE

WARNING! DO NOT MODIFY MACHINE OR ATTACHMENTS



Modifications may weaken the integrity of the and may impair the function, safety, life, and performance of the . When making repairs, use only the manufacturer's genuine parts, following authorized instructions. Other parts may be substandard in fit and quality. Never modify any ROPS (Roll Over Protection Structure) or FOPS (Falling Object Protective Structure) equipment or device. Any modifications must be authorized in writing by the manufacturer.

10703 & 10743 PALLET FORK PARTS ILLUSTRATION & LIST

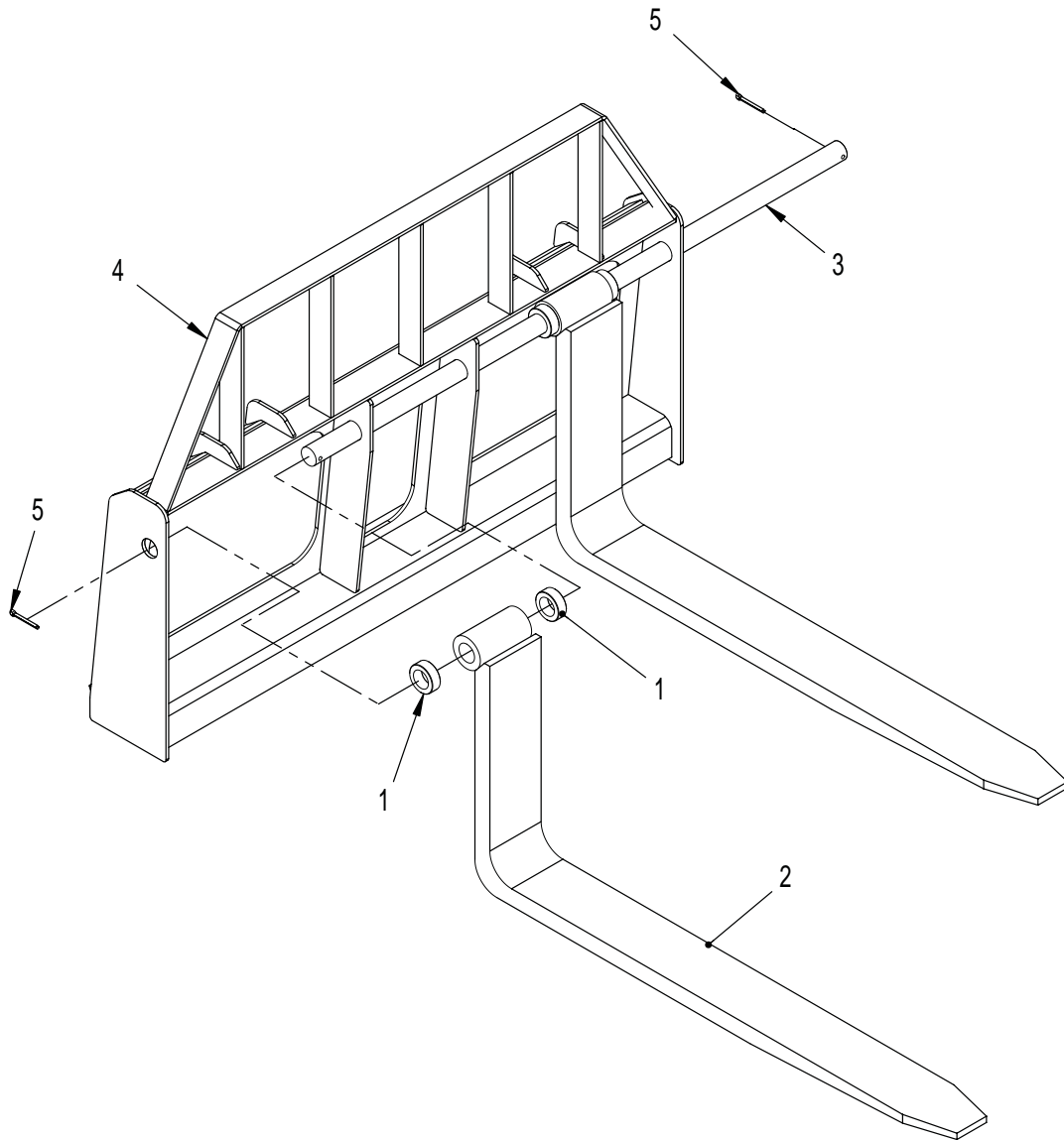

ITEM	QTY.	10703-42	10703-48	10743-42	10743-48	DESCRIPTION
1	4		07-10128		07-10129	Set Collar
2	2	07-10137	07-10143	07-10138	07-10147	Floating Fork Tines
3	1		13-52090		13-52019	Fork Rod
4	1		13-52334		13-53383	Frame Weldment
5	2		1613		1613	Cotter Pin .25" x 2" Grade 2

NOTE: All parts are the same as 10703-48 or 10743-48 except for those parts numbered under the other models.

Limited Warranty

Except for the Excluded Products as described below, all new products are warranted to be free from defects in material and/or workmanship during the Warranty Period, in accordance with and subject to the terms and conditions of this Limited Warranty.

1. Excluded Products. The following products are excluded from this Limited Warranty:

(a) Any cable, part that engages with the ground (i.e. sprockets), digging chain, bearing, teeth, tamping and/or demolition head, blade cutting edge, pilot bit, auger teeth and broom brush that either constitutes or is part of a product.

(b) Any product, merchandise or component that, in the opinion of Paladin Light Construction¹, has been (i) misused; (ii) modified in any unauthorized manner; (iii) altered; (iv) damaged; (v) involved in an accident; or (vi) repaired using parts not obtained through Paladin Light Construction.

2. Warranty Period. The Limited Warranty is provided only to those defects that occur during the Warranty Period, which is the period that begins on the first to occur of: (i) the date of initial purchase by an end-user, (ii) the date the product is first leased or rented, or (iii) the date that is six (6) months after the date of shipment by Paladin Light Construction as evidenced by the invoiced shipment date (the "Commencement Date") and ends on the date that is twelve (12) months after the Commencement Date.

3. Terms and Conditions of Limited Warranty. The following terms and conditions apply to the Limited Warranty hereby provided:

(a) Option to Repair or Replace. Paladin Light Construction shall have the option to repair or replace the product.

(b) Timely Repair and Notice. In order to obtain the Limited Warranty, (i) the product must be repaired within thirty (30) days from the date of failure, and (ii) a claim under the warranty must be submitted to Paladin Light Construction in writing within thirty (30) days from the date of repair.

(c) Return of Defective Part or Product. If requested by Paladin Light Construction, the alleged defective part or product shall be shipped to Paladin Light Construction at its manufacturing facility or other location specified by Paladin Light Construction, with freight PRE-PAID by the claimant, to allow Paladin Light Construction to inspect the part or product.

Claims that fail to comply with any of the above terms and conditions shall be denied.

LIMITATIONS AND EXCLUSIONS.

THIS LIMITED WARRANTY IS IN LIEU OF ALL OTHER WARRANTIES, EXPRESS OR IMPLIED, INCLUDING WITHOUT LIMITATION THE WARRANTIES OF MERCHANTABILITY, FITNESS FOR A PARTICULAR PURPOSE AND ANY WARRANTY BASED ON A COURSE OF DEALING OR USAGE OF TRADE.

IN NO EVENT SHALL PALADIN LIGHT CONSTRUCTION BE LIABLE FOR CONSEQUENTIAL OR SPECIAL DAMAGES.

IN NO EVENT SHALL PALADIN LIGHT CONSTRUCTION BE LIABLE FOR ANY LOSS OR CLAIM IN AN AMOUNT IN EXCESS OF THE PURCHASE PRICE, OR, AT THE OPTION OF PALADIN LIGHT CONSTRUCTION, THE REPAIR OR REPLACEMENT, OF THE PARTICULAR PRODUCT ON WHICH ANY CLAIM OF LOSS OR DAMAGE IS BASED. THIS LIMITATION OF LIABILITY APPLIES IRRESPECTIVE OF WHETHER THE CLAIM IS BASED ON BREACH OF CONTRACT, BREACH OF WARRANTY, NEGLIGENCE OR OTHER CAUSE AND WHETHER THE ALLEGED DEFECT IS DISCOVERABLE OR LATENT.

¹Attachment Technologies Inc., a subsidiary of Paladin Brands Holding, Inc. (PBHI) is referred to herein as Paladin Light Construction.

