



609 & 611 POWER BACKHOES OPERATOR'S MANUAL



PALADIN LIGHT CONSTRUCTION



SERIAL NUMBER: _____

MODEL NUMBER: _____

Manual Number: OM554
Part Number: 75454
Rev. 4

TABLE OF CONTENTS

POWERBACKHOES

TO THE OWNER	A
SAFETY PRECAUTIONS	B
Safety Alert Symbol	
The Operator	
The Vehicle	
Working With The Backhoe	
Transporting The Backhoe	
Maintenance	
INTERNATIONAL SYMBOLS	C
PRE-OPERATION	D
General Information	
Preparing the Vehicle	
Bucket Options	
Backhoe - Major Component Nomenclature	
OPERATING INSTRUCTIONS	G
General Information	
Controls	
Before You Start Digging	
Basic Digging Technique	
Special Applications	
Transporting	
LUBRICATION	H
General Information	
Backhoe Lubrication Diagram	
MAINTENANCE	L
Every 8 Hours	
Every 40 Hours	
Control Valve	
Replacing Bucket Tooth Points	
Changing Buckets	
Hose Routing	
Cylinder Seal Replacement	
BACKHOE STORAGE	M
TROUBLE SHOOTING	N
BOLT TORQUE	O
SPECIFICATIONS	P
DECALS	Q
PRE-DELIVERY CHECKLIST	R
LIMITED WARRANTY	S

TO THE OWNER

GENERAL COMMENTS

Congratulations on the purchase of your new backhoe! Your backhoe was carefully designed and manufactured to give you many years of dependable service. Your backhoe will require some minor maintenance (such as cleaning and lubricating) to keep it in top working condition. Be sure to observe all maintenance procedures and safety precautions in this manual and on the safety decals located on the backhoe and on any equipment on which the backhoe is mounted.

ABOUT THIS MANUAL

Read this manual before using your backhoe. This manual has been designed to help you to do a better, safer job. Read this manual carefully, and become familiar with the operating procedures before attempting to operate your new backhoe. **Remember, never let anyone operate this backhoe without them having read and completely understand the "Safety Precautions" and "Operating Instructions" section of this manual, or having them be fully trained by an experienced, qualified person who has read and completely understands the "Safety Precautions" and "Operating Instructions" (see sections B and G respectively).**

SERVICE

When servicing your backhoe, remember to use only original manufacturer replacement parts. Substitute parts may not meet the standards required for safe, dependable operation.

To facilitate parts ordering, record the model and serial number of your backhoe in the space provided on this page. This information may be obtained from the backhoe identification plate located on the left side of the backhoe console.

MODEL _____ **SERIAL NO.** _____

Your parts department needs this information to insure that you receive the correct parts or attachments for your specific backhoe.

SAFETY ALERT SYMBOL



This is the "Safety Alert Symbol" used by this industry. This symbol is used to warn of possible injury. Be sure to read all warnings carefully. They are included for your safety and for the safety of others working around you.

SAFETY PRECAUTIONS

TAKE NOTE! THIS SAFETY ALERT SYMBOL FOUND THROUGHOUT THIS MANUAL IS USED TO CALL YOUR ATTENTION TO INSTRUCTIONS INVOLVING YOUR PERSONAL SAFETY OR OTHERS. FAILURE TO FOLLOW THESE INSTRUCTIONS CAN RESULT IN INJURY OR DEATH.



THIS SYMBOL MEANS:

ATTENTION!

BECOME ALERT!

YOUR SAFETY IS INVOLVED!

SIGNAL WORDS: Note the use of signal words DANGER, WARNING, and CAUTION with the safety messages. The appropriate signal word for each has been selected using the following guidelines:

DANGER: Indicates an imminently hazardous situation, which if not avoided, will result in death or serious injury. This signal word is to be limited to the most extreme situations, **typically for machine components which, for functional purposes, cannot be guarded.**

WARNING: Indicates a potentially hazardous situation, which if not avoided, could result in death or serious injury, and **includes hazards that are exposed when guards are removed. It may also be used to alert against unsafe practices.**

CAUTION: Indicates a potentially hazardous situation, which if not avoided, **may result in minor or moderate injury. It may also be used to alert against unsafe practices.**

THE OPERATOR

A careful operator is the best operator. Most accidents can be avoided by taking certain precautions. The following precautions are suggested here to help prevent accidents. Read and understand these safety precautions before operating the vehicle and backhoe. Make sure that the equipment is operated only by responsible individuals with the proper instruction. The operator should be familiar with the controls, all safety precautions and all potential hazards.

This is the "Safety Alert Symbol" used by this industry.



Remember, when you see this symbol it means: **ATTENTION BECOME ALERT! YOUR SAFETY IS INVOLVED!** This symbol with its appropriate warnings are throughout this book. Be sure all operators read them before using the backhoe.

THE VEHICLE

1. **READ THE ENTIRE VEHICLE AND BACKHOE OPERATOR'S SAFETY MANUALS BEFORE EVER ATTEMPTING TO USE THE VEHICLE. THIS KNOWLEDGE IS NECESSARY FOR SAFE OPERATION.**
2. **Follow all safety decals on the vehicle. Keep them clean and replace them if they become worn and hard to read.**
3. **Pay attention to the job at hand. Do not let your mind lose concentration on what you are doing.**
4. **Know the limitations of your equipment. Do not use equipment for anything other than what it was originally designed.**
5. **Always use the seat belt if the vehicle has a ROPS. Do not use it if there is no ROPS. Check the seat belt daily and replace if frayed or damaged.**

SAFETY PRECAUTIONS

6. **Do not take passengers** on the vehicle or backhoe. There is no safe place for a passenger.
7. **Use the handholds and step plates** when getting on/off the vehicle. Failure to do so could cause a fall.
8. **Inspect the vehicle** before you try to operate the unit. Check for needed maintenance or repairs and be sure to have them done before using the equipment.
9. **Before performing maintenance**. Set the parking brake, place the gear shift lever in neutral, turn off the vehicle and remove the key.
10. **Wear appropriate clothing** such as a hard hat, safety glasses, ear plugs, etc. Do not wear loose fitting clothing, it could get caught on the equipment.
11. **Never operate or transport unit with covers or shields removed**.
12. **Never leave unit running unattended**. Follow vehicle operator's manual for correct operation.
13. **Reduce speed** when driving over rough terrain, on a slope, or turning, to avoid overturning the vehicle.
14. **Do not smoke** when refueling the vehicle. Allow room in the gas tank for expansion. Wipe up any spilled fuel. Secure cap tightly when done.
15. **Do not modify the backhoe or it's mounting frames** in any way unless authorized by ATI Incorporated to do so. Unauthorized modifications could result in equipment damage and/or personal injury.
16. **Look before backing**.

WORKING WITH THE BACKHOE

1. **Never operate backhoe by standing up on, or beside the machine**. Operate only from the backhoe seat.
2. **Do not lift or carry people on the backhoe**, they could fall and be crushed.
3. **Do not adjust relief valve setting**. This valve is factory set and should be adjusted only by a qualified service person. Incorrect valve setting could result in equipment damage and/or personal injury.
4. **Check your work area**. Avoid hitting overhead electrical wires, underground cables and pipes, fence post, gas lines, etc.

SAFETY PRECAUTIONS

5. **Block off work area** from all bystanders, livestock, etc. Allow plenty of room for backhoe reach and swing.
6. **When operating on slopes, dig with the backhoe uphill, and avoid full reach and swinging the backhoe bucket to the downhill side.** Tipping could result.
7. **Operate backhoe only from backhoe seat.**
8. **Use your backhoe only for digging.** Do not use it to pull things, as a battering ram, or attach ropes, chains, etc., to the unit.
9. **Never work under raised stabilizers or a raised bucket.**
10. **Lower stabilizers and bucket when removing backhoe.** This will increase the stability of the unit.
11. **Do not dig close to stabilizers,** the ground could collapse from under the backhoe
12. **Do not lift loads in excess of backhoe capacity.**
13. **Always lower the backhoe bucket and stabilizers to the ground,** shut off engine, remove key, and apply the parking brake before leaving the unit unattended.

TRANSPORTING THE BACKHOE

1. **Be sure to engage the boom lock and swing lock before transporting backhoe.** Failure to do so could cause an unstable traveling condition.
2. **Allow for height of backhoe** when transporting backhoe so as not to catch unit on low overhangs or wires.
3. **When driving on public roads** use safety lights, reflectors, Slow Moving Vehicle signs, etc., to prevent accidents. Check with local governments for regulations that may affect you.
4. **Do not drive close to ditches, excavations, etc.,** cave in could result. Drive slow over rough terrain.

SAFETY PRECAUTIONS

MAINTENANCE

1. **Never work on equipment while it is running.** Block up equipment, set hand brake, lower bucket and stabilizers, turn off the tractor and remove the key before performing repairs.
2. **Never make hydraulic repairs while the system is under pressure, or the cylinders are under load.** Serious personal injury or death could result.
3. **Observe proper maintenance schedules and repairs to keep unit in safe working order.**
4. **Always wear safety goggles or glasses when working on equipment.**
5. **Use a brass drift and hammer when pressing out pins to prevent the pin from shattering.**

WARNING! Escaping fluid under pressure can have sufficient force to penetrate the skin, causing serious personal injury. Fluid escaping from a very small hole can be almost invisible. Use a piece of cardboard or wood, rather than hands to search for suspected leaks.





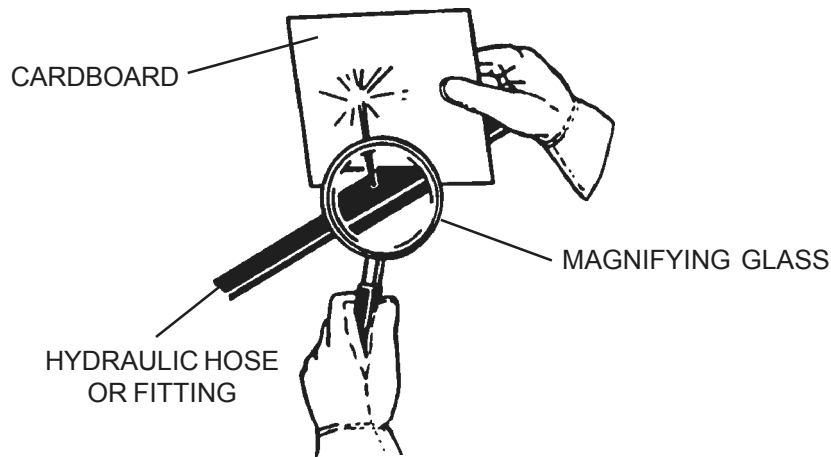

Keep unprotected body parts, such as face, eyes, and arms as far away as possible from a suspected leak. Flesh injected with hydraulic fluid may develop gangrene or other permanent disabilities.

If injured by injected fluid, see a doctor at once. If your doctor is not familiar with this type of injury, ask him to research immediately to determine proper treatment.



INTERNATIONAL SYMBOLS

As a guide to the operation of your equipment, various international symbols have been utilized on the instruments and controls. The symbols are shown below with an indication of their meaning.

	Engine speed		Alternator charge
	Hours recorded		Power take-off (on)
	Engine water temperature		Power take-off (off)
	Lights		"Tortoise," slow or minimum setting
	Horn		"Hare," fast or maximum setting
	Engine oil pressure		Caution
	Hazard warning		Control lever operating direction
	Axle connect		Rock shaft (raised)
	Axle disconnect		Rock shaft (lowered)
	Continuously variable		Remote cylinder (extended)
	Increase		Remote cylinder (retracted)
	Decrease		Remote cylinder (FLOAT)
	Diesel fuel		Differential lock
	Creeper range		Read operators manual
	High range		Neutral
	Low range		Forward
			Reverse

PRE-OPERATION

609 & 611 POWER BACKHOES

GENERAL INFORMATION

The purpose of this manual is to assist in setting up, operating and maintaining your backhoe. Read it carefully. It furnishes information and instructions that will help you achieve years of dependable performance.

Right and left, when referred to in this manual, are determined from the operator's control position when facing the backhoe.

The illustrations and data used in this manual were current (according to the information available to us) at the time of printing, however, we reserve the right to redesign and change the backhoes as may be necessary without notification.

PREPARING THE VEHICLE

WARNING! Never let anyone operate this vehicle and backhoe without understanding all of the "Safety Precautions" and "Operating Instructions" sections of this manual. (See Section B and G respectively.) Always choose hard, level ground to park the vehicle on and set the brake so that the unit cannot roll.



BACKHOE

Basic backhoes are shipped complete with bucket. However, several bucket options are available for the backhoe. Refer to the table for proper identification of backhoe bucket options.

STANDARD POWER DIG BUCKET ASSEMBLIES

12"	#68212
16"	#68216
18"	#68218
20"	#68220
24"	#68224

SEVERE DUTY POWER DIG BUCKET ASSEMBLIES

12"	#85012
16"	#85016
18"	#85018
20"	#85020
24"	#85024

PRE-OPERATION

BACKHOE MAJOR COMPONENT NOMENCLATURE 609 & 611 POWER BACKHOES

GENERAL INFORMATION

Throughout this manual, reference is made to various backhoe components. The purpose of this page is to acquaint you with the various names of these components. This knowledge will be helpful when reading through this manual or when ordering service parts.

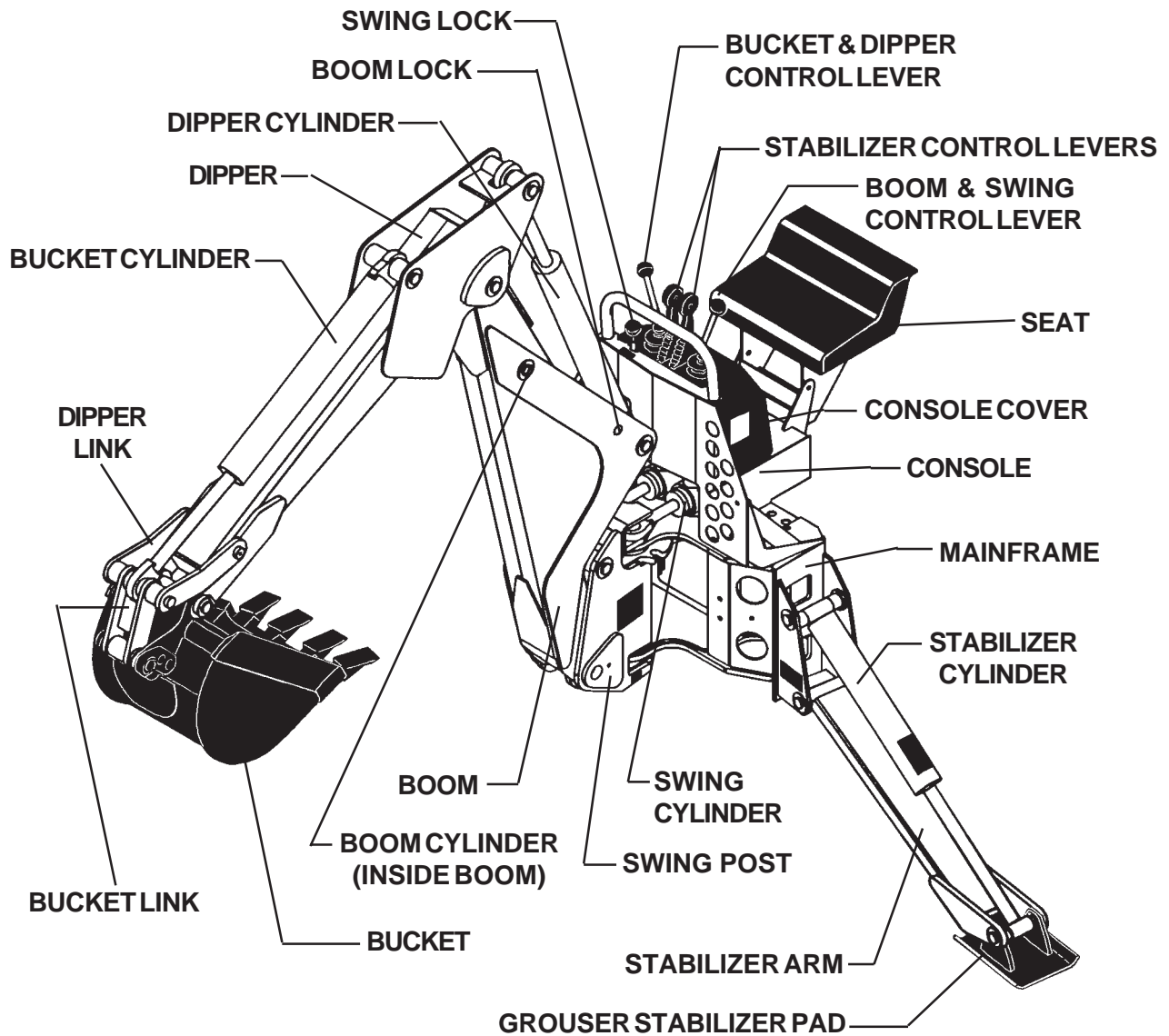

OPERATING INSTRUCTIONS

CONTROLS

GENERAL INFORMATION

Your backhoe is operated by four different control levers. Two are for stabilizer operation and the other two operate the swing, boom, dipper, and bucket functions. The information contained below will help you become familiar with the operation of each control lever. Read the safety precautions (Section B) of this manual before attempting to use the backhoe. Remember, right and left when referred to on this page are determined by the operator's position seated at the backhoe controls facing the bucket.

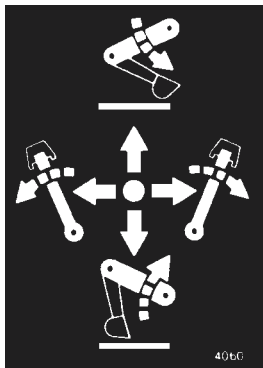

**BOOM/SWING
CONTROL LEVER**

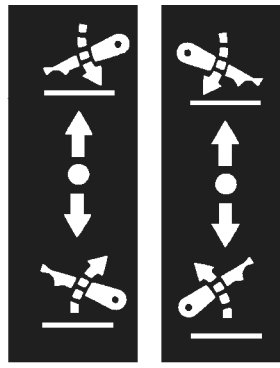

**LEFT RIGHT
STABILIZERS**

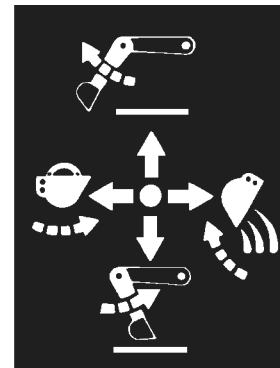

**DIPPER/BUCKET
CONTROL LEVER**

BACKHOE STABILIZER LEVERS

Moving the stabilizer lever(s) forward will bring the backhoe stabilizer (s) "Down". Moving the stabilizer lever(s) rearward will raise the backhoe stabilizers "Up". Both stabilizers are required to be down for proper stability of the backhoe when in operation.

BOOM/SWING LEVER (LEFT HAND LEVER)

Pushing the boom/swing lever forward will "Lower" the boom dipstick and bucket. Pulling the lever rearward will "Lift" the boom, dipstick, and bucket.

Pushing the boom/swing lever to the left will swing the boom and bucket to the "Left". Pushing the lever to the right will swing the boom, and bucket to the "Right".

DIPPER/BUCKET LEVER (RIGHT HAND LEVER)

Pushing the dipper/bucket lever forward will move the dipper "Out" or away from the operator. Pulling the lever rearward will move (crowd) the dipper "In" or toward the operator.

Pushing the dipper/bucket lever to the left will "Fill" or curl the bucket (move inward). Pushing the lever to the right will "Dump" the bucket (move outward).

OPERATING INSTRUCTIONS

OPERATING TECHNIQUES ATTACHMENT TYPE BACKHOES

GENERAL INFORMATION

When operating the backhoe, smoothness of technique should be strived for at all times. Smoothness will come with experience and practice at feathering the controls. Establish a flowing digging cycle to increase operator efficiency and save unnecessary wear on the machine.

Observe the following points to obtain the best results and to fully utilize the digging force of the backhoe.

WARNING! Operate the backhoe only when seated at the controls. Any other method could result in serious personal injury or death.



Never attempt to drive the tractor when seated at the backhoe controls.

Check the prospective digging area for hidden utility lines before operating the backhoe or when in doubt of their location, contact the local utility companies. When operating the backhoe in an area where utilities are expected to be present, throttle the backhoe down and proceed with caution. If you feel the backhoe bucket made contact with anything out of the ordinary, stop digging at once. Have the obstruction checked by hand. If a utility line has been damaged, contact the affected utility at once.

BEFORE YOU START DIGGING

Before any excavating is started, it is always a good idea to plan out the job first. Various things need to be considered and taken into account prior to the actual digging. The operator should inspect the job site and take notice of any potential hazards in the area. He should have a complete understanding of the tasks he is expected to perform. Figure out what will be done with the spoil (excavated soil), will it be used to backfill or be trucked out? What are the soil conditions like? Will you have to work around others? Etc.

Once you have become familiar with the job site and understand the job requirements, it is time to set up for the actual digging. Position the backhoe in such a way as to minimize repositioning the unit and to maximize digging efficiency. Consider the placement of spoil and position the backhoe to be able to dig the maximum amount of soil, accurately, while leaving enough room for the spoil removed to be piled in the desired area.

OPERATING INSTRUCTIONS

OPERATING TECHNIQUES ATTACHMENT TYPE BACKHOES

BEFORE YOU START DIGGING (CONTINUED)

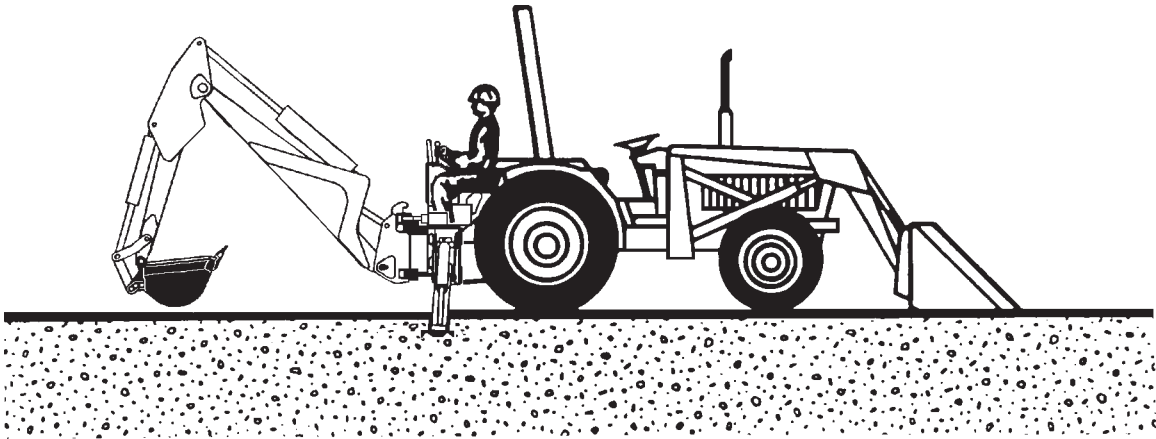

Once the unit is positioned, lower the stabilizers to the ground. The tires should still be supporting most of the vehicle weight with the stabilizers relieving only part of the weight, and mainly acting to give the unit a wider base for increased stability and to keep the unit from moving or bouncing with backhoe use. The front end loader should also be lowered if the unit is so equipped. The vehicle should at no time be supported by the stabilizers and loader with any of its wheels off the ground. Severe damage to the vehicle could result. When operating the unit on a delicate surface (such as concrete, or stone work) or on sandy, loose, or soft ground place plywood under the stabilizers to help distribute the load over a wider area.

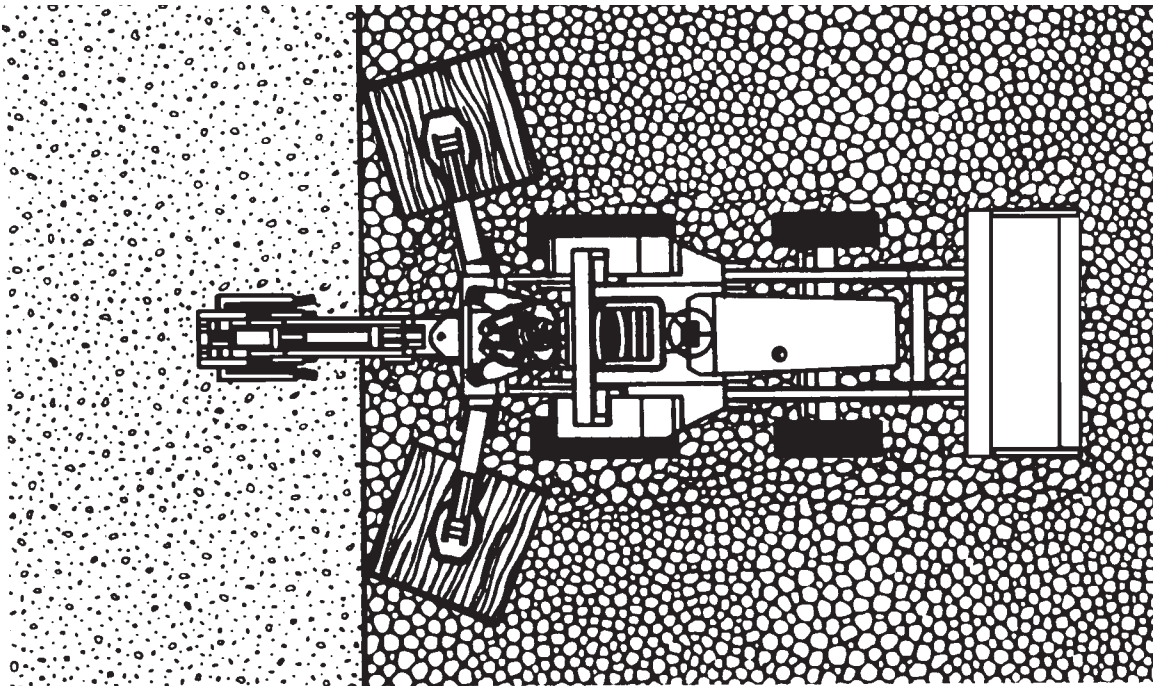

6879
3-7-96

OPERATING INSTRUCTIONS

OPERATING TECHNIQUES ATTACHMENT TYPE BACKHOES

BASIC DIGGING TECHNIQUE

When starting an excavation, make the first cut of each section shallow, being careful to follow the exact layout of the excavation. The reason for the shallow cut is to minimize damage to the sod and to facilitate replacement. These first cuts are also important because they will act as guides for the remaining cuts, thus getting the first few cuts as accurate as possible will help in keeping all future cuts accurate.

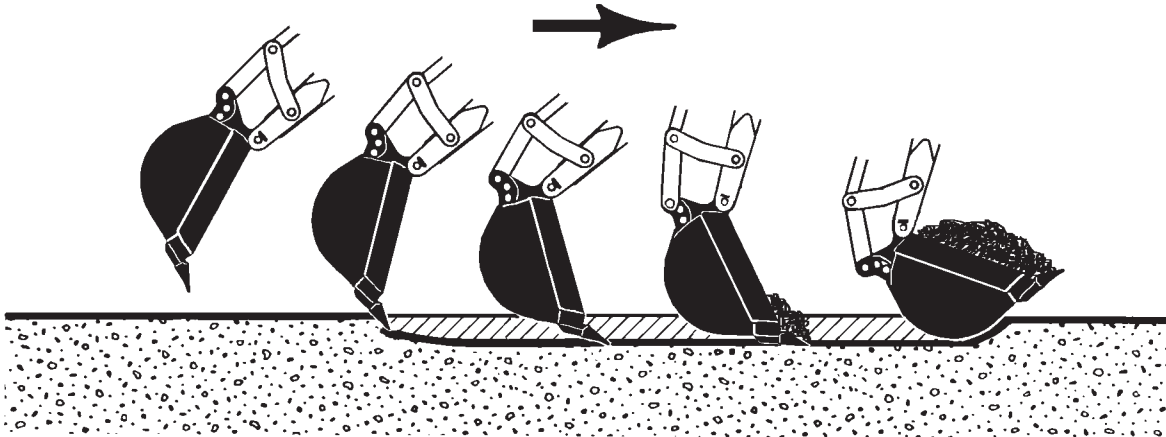

When digging with the backhoe, extend the boom, dipper and bucket out, away from the operator. Lower the boom and dipper to start the digging process. The bucket teeth should be at a 30° to 45° entry angle. As the digging starts, curl the bucket until the cutting edge is level with the horizon. Crowd the bucket in toward the operator working the bucket lever to keep the bucket level. As the bucket moves toward the operator, manipulate the boom lever to keep the cut level. At the end of the digging cycle, crowd the dipper out and completely curl the bucket while lifting it from the excavation. Once you have cleared the excavation, swing the bucket to the spoil pile. Start to dump the bucket before the pile is approached. Once the bucket is empty, swing the unit back to the excavation, positioning the bucket and dipper for the next cut in the process. The whole digging process should be one smooth cycle that is repeated until the excavation is completed.

When the excavation has been dug to within six inches of the finished bottom, clear and touch up the sides of the excavation. Use the flat sides of the bucket to scrape off any high spots. Dislodge any exposed rocks if they seem loose. When finishing walls, finish the far wall by curling the bucket out, crowding the dipper out, and forcing the bucket down. To finish the closest wall, lift the bucket up and curl it in.

OPERATING INSTRUCTIONS

OPERATING TECHNIQUES ATTACHMENT TYPE BACKHOES

BASIC DIGGING TECHNIQUES (CONTINUED)

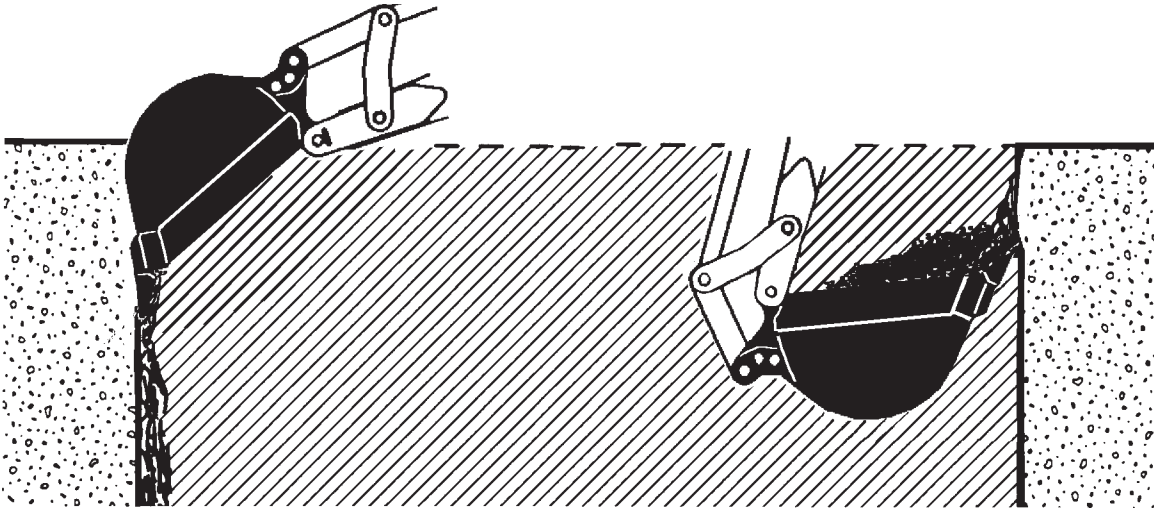

Once the sides are cleaned up, finish grading the bottom of the excavation. This is done by making the remaining cuts long and shallow, concentrating on making them level and smooth. Remove any remaining spoil. Check the excavation bottom for depth and levelness, making any adjusting cuts as needed.

The basic steps just listed at the same regardless of the excavation. All other digging jobs are simply variations of this basic procedure. Remember to make your cuts in smooth cycles. This will reduce operator fatigue and machine wear while increasing productivity and efficiency.

SPECIAL APPLICATIONS

TRENCHING BETWEEN A BUILDING AND AN OPEN EXCAVATION

Start the trench at the building and trench toward the open excavation. Dig toward the open excavation until there is just enough room to move the unit out from between the trench and open excavation.

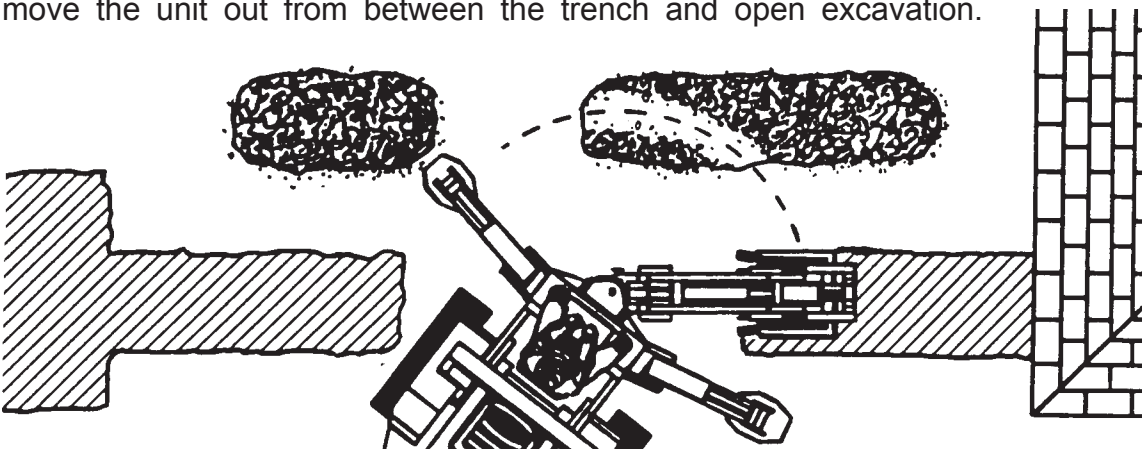

6881
3-7-96

OPERATING INSTRUCTIONS

OPERATING TECHNIQUES ATTACHMENT TYPE BACKHOES

TRENCHING BETWEEN A BUILDING AND AN OPEN EXCAVATION (CONTINUED)

Position the unit so the backhoe swing post is over the centerline of the trench connection. Dig with the backhoe at extreme swing positions, and in as close to the stabilizers as possible. Pile the soil on the opposite side of the trenches.

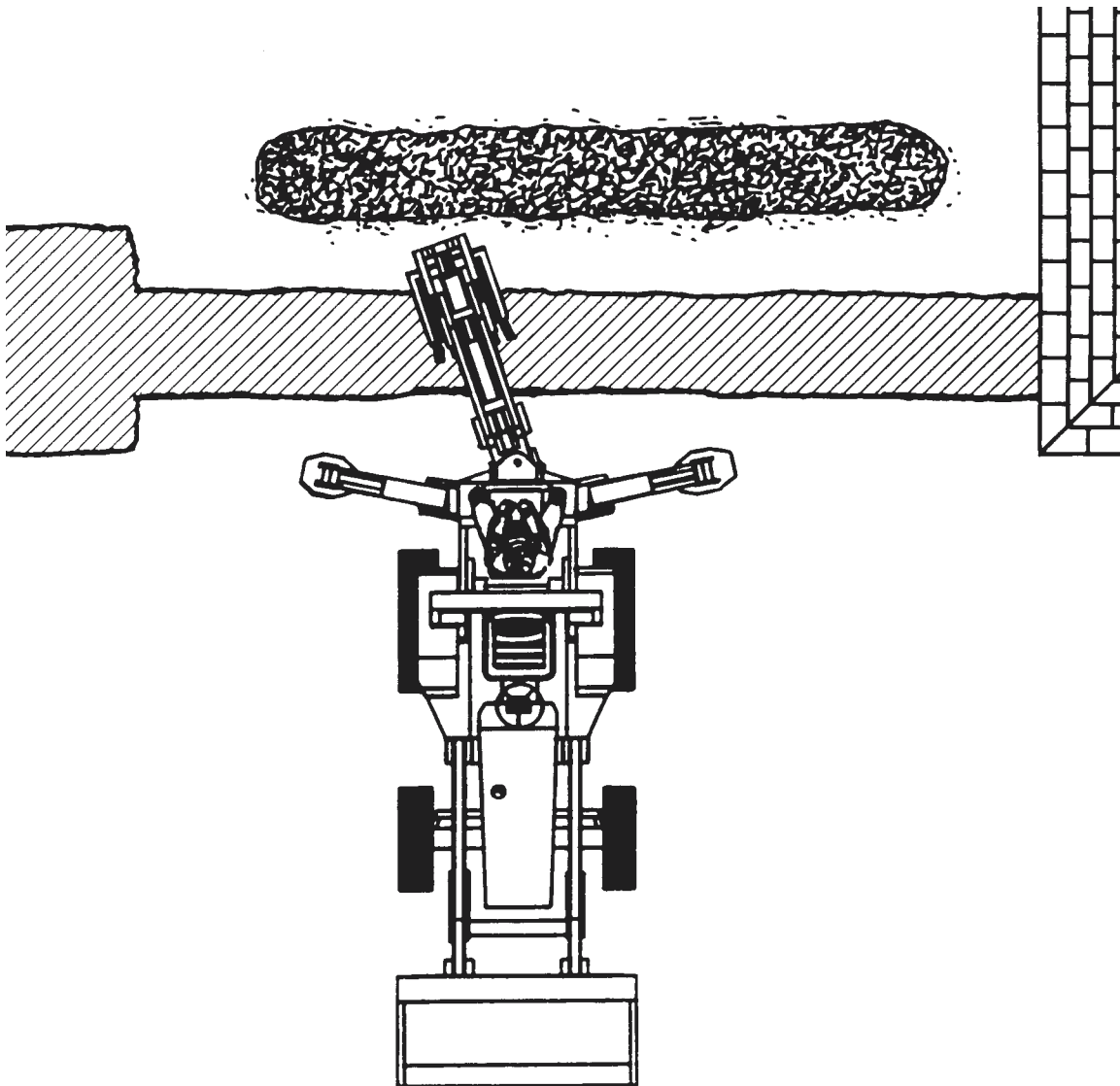

Position the unit forward so the two trenches can be connected. Pile the spoil on the opposite side of the trench.

3991
8-20-91-3

OPERATING INSTRUCTIONS

OPERATING TECHNIQUES ATTACHMENT TYPE BACKHOES

EXCAVATING ON SLOPES

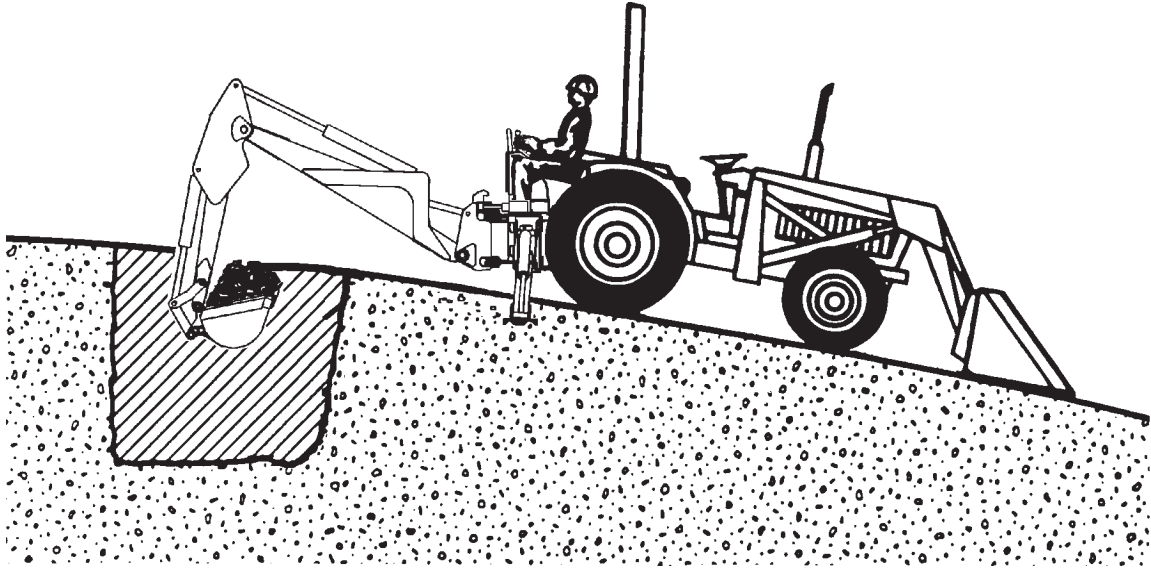

When digging on slopes always face the backhoe upgrade whenever possible. It may be necessary to cut a level surface in the hill for the backhoe to sit in when operating on slopes. This will allow the backhoe to sit level for digging the main excavation. Pile the spoil from the surface downhill. When digging the main excavation, pile the spoil uphill.

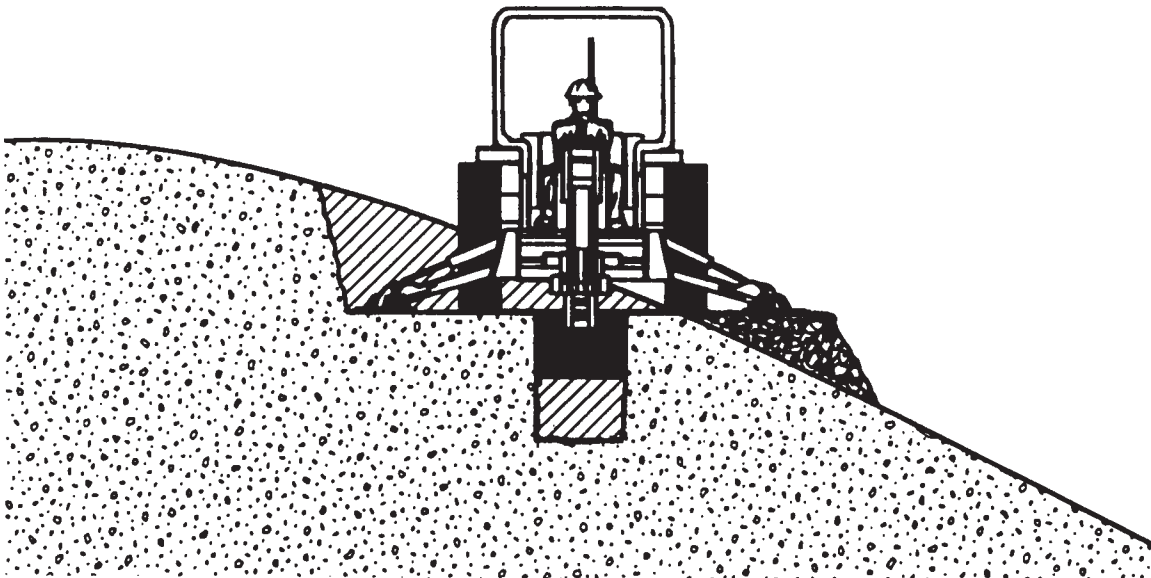

6882
3-7-96

OPERATING INSTRUCTIONS

OPERATING TECHNIQUES ATTACHMENT TYPE BACKHOES

PIPELINE LEAK REPAIR

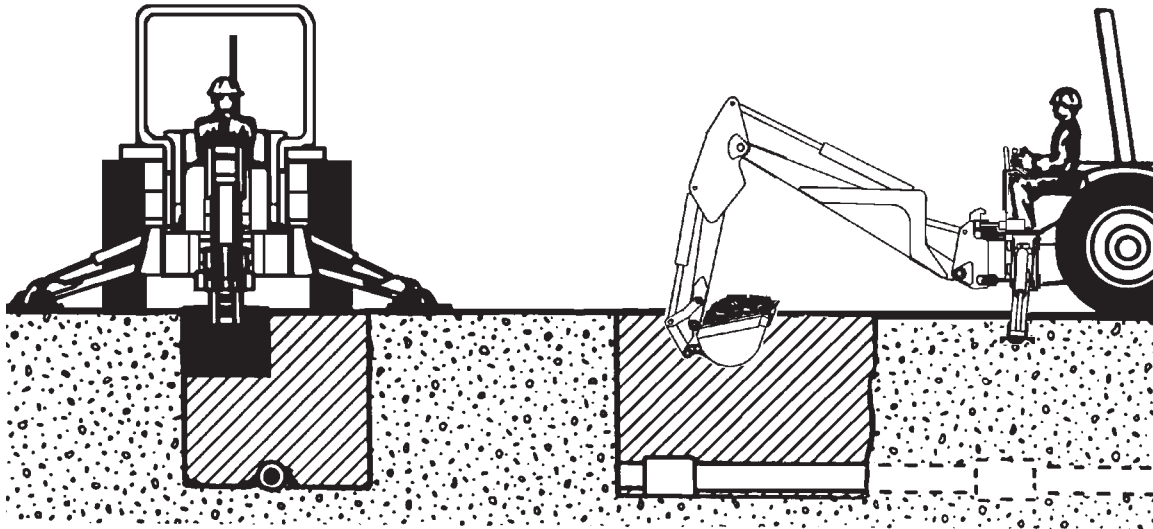

To check for pipeline leaks, start by digging a bellhole about six feet wide and ten feet long. Then, dig lengthwise along the pipeline to locate the leak. Once the leak is located, position the unit to dig at grade level on both sides of the pipeline. If a section of pipe is to be replaced, strip the soil from both ends of the bellhole. Enlarge the hole enough to allow the workmen adequate working space in the leak area.

DIGGING STRAIGHT WALL SHALLOW BASEMENTS

Begin at one corner, and remove as much material as possible to grade level. Reset the unit forward and continue digging to the grade level. Progress around the edge of the basement, finishing each corner as you come to it.

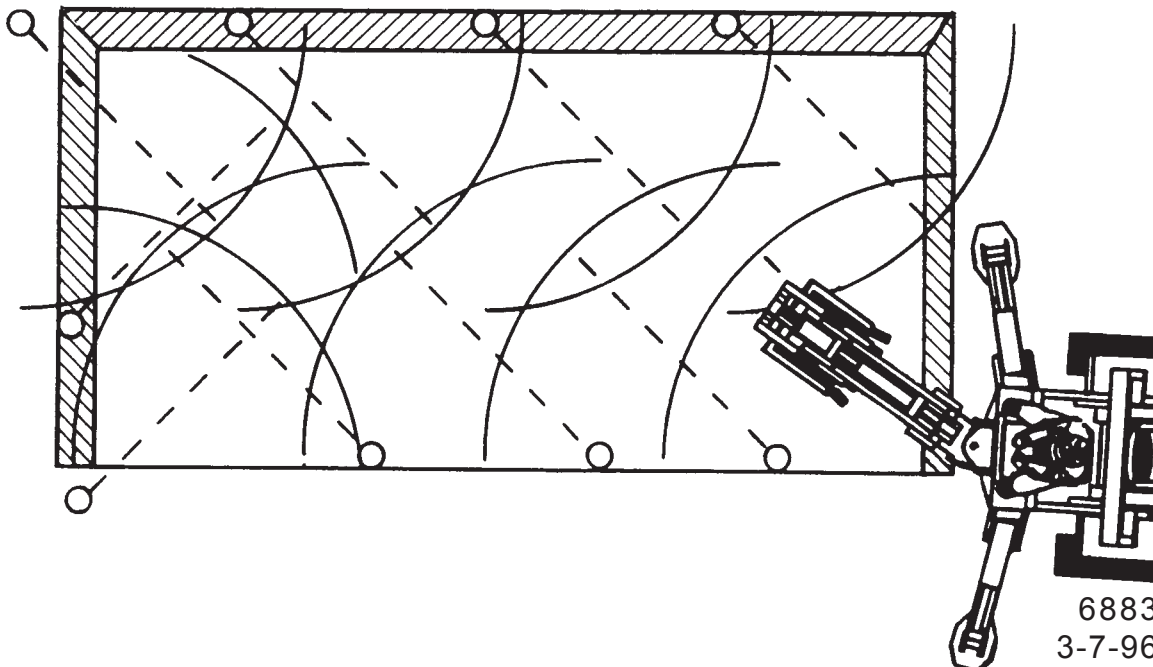

6883
3-7-96

OPERATING INSTRUCTIONS

OPERATING TECHNIQUES ATTACHMENT TYPE BACKHOES

MISCELLANEOUS - BACKFILLING

To backfill an excavation, lower the extended bucket into the spoil pile. Curl the bucket and lift it clear of the spoil pile. Swing the bucket to the excavation and extend the bucket. Return the bucket to the spoil pile and continue the cycle until the job is completed.

IMPORTANT: Do not backfill by using the swing circuit and dragging the bucket sideways. Doing so could cause damage to the dipper, boom, and swing cylinders or mainframe.

IMPORTANT: Avoid constant jarring or hammering contact between the spoil pile and the loaded bucket as this may cause premature wear to the backhoe pins and bushings.

MISCELLANEOUS - EXCAVATING BY A WALL

To excavate by a wall, where the wall will interfere with the stabilizer placement, move the backhoe in at an angle to the wall. Concentrate on getting the swing pin as close to the wall as possible while leaving enough swing arc left to dump the spoil.

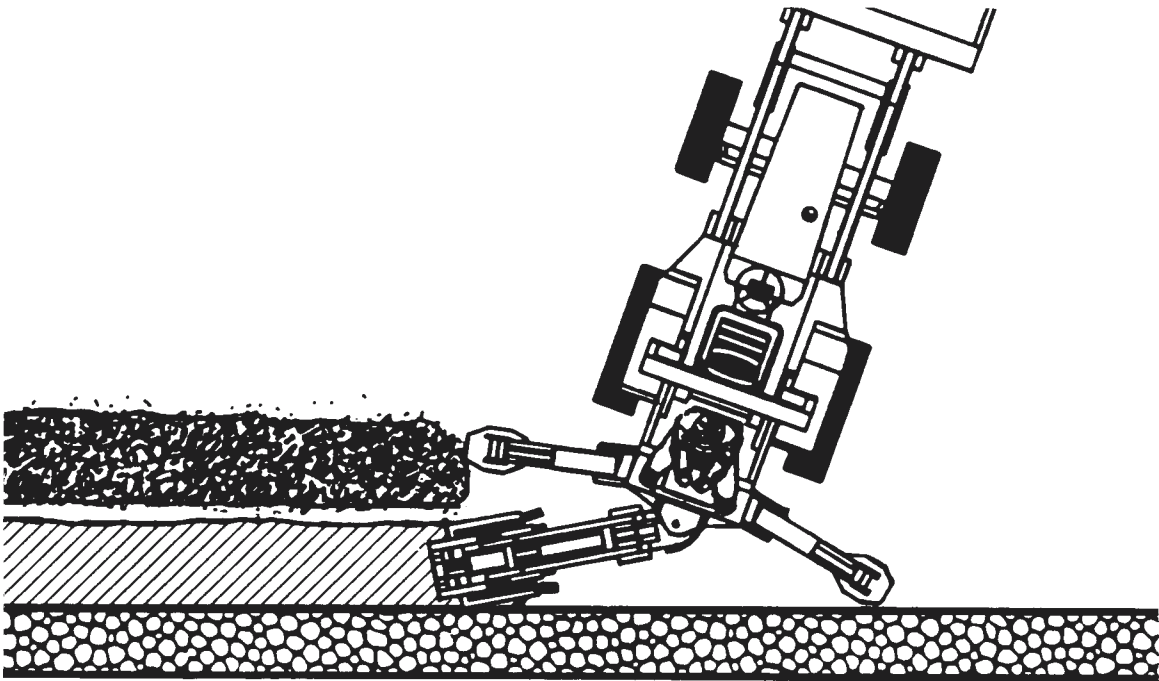

MISCELLANEOUS - HARD GROUND OPERATION

When digging in hard ground, it may be necessary to decrease the bucket angle of entry to the point where the back of the bucket almost contacts the ground. It may also be necessary to apply downward pressure with the boom on the bucket.

OPERATING INSTRUCTIONS

TRANSPORTING

GENERAL INFORMATION

Follow the simple steps listed below when preparing the backhoe for transportation between work sites. Read and follow the safety precautions for backhoe transporting listed in Section B of this manual before moving the backhoe.

1. Before transporting the backhoe, raise the boom, dipper, and bucket to the transporting position.
2. Engage the swing lock (if so equipped) by pushing down and to the left on the red swing lock ball handle.
3. Engage the boom lock by moving the boom lock handle to the left/down therefore locking the boom to the swing post in the transporting position.
4. Raise all stabilizers.

CAUTION! Be sure to install a SMV (Slow Moving Vehicle) sign on the backhoe dipper before attempting to transport the backhoe.



When transporting the backhoe on a road or highway at night or during the day, use accessory lights and devices for adequate warning to the operators of other vehicles. In this regard, check local government regulations.

Always drive slowly over uneven terrain to avoid tipping the backhoe.

LUBRICATION

609 & 611 POWER BACKHOES

GENERAL INFORMATION

Economical and efficient operation of any machine is dependent upon regular and proper lubrication of all moving parts with a quality lubricant. Neglect leads to reduced efficiency, heavy draft, wear, breakdown, and needless replacement parts.

All parts provided with grease fittings should be lubricated as indicated. If any grease fittings are missing, replace them immediately. Clean all fittings thoroughly before using grease gun.

IMPORTANT: Avoid excessive greasing. Dirt collects on exposed grease and greatly increases wear. After greasing, wipe off excessive grease from fittings.

LUBRICATION SYMBOLS

The following symbol is used on the lubrication diagram printed on the following page. It is reproduced here with its meaning for your convenience.



Lubricate daily or every 8 hours of operation, whichever comes first, with SAE Multi-Purpose Lubricant or an equivalent SAE Multi Purpose type grease.

CAUTION! Shut off vehicle engine before lubricating equipment.



LUBRICATION

609 & 611 POWER BACKHOES

BACKHOE LUBRICATION DIAGRAM

The following diagram is provided to help you locate all the points on your backhoe that need lubricating. Be sure to follow the lubrication intervals as noted by the lubrication symbols used on this page. Always replace any missing grease fittings as soon as possible.

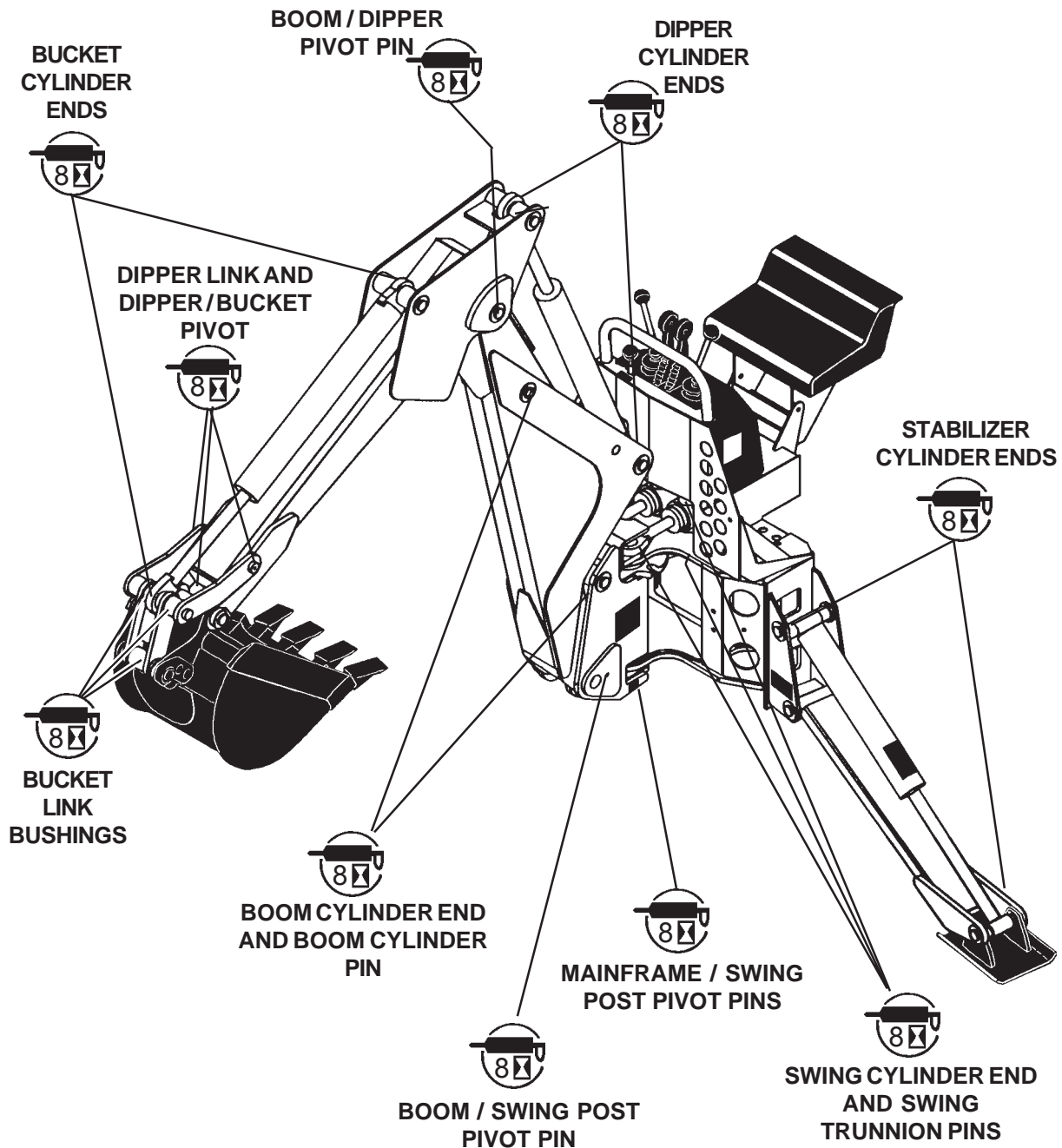

GENERAL MAINTENANCE

GENERAL INFORMATION

Regular maintenance is the key to long equipment life and safe operation. Maintenance requirements have been reduced to an absolute minimum. However, it is very important that these maintenance functions be performed as described below.

EVERY 8 HOURS OF OPERATION

Grease all swivel points (ram and base end of all cylinders) thoroughly. Excessive wear and even mechanical damage to pins and cylinders can result from inadequate lubrication. Use a multi-purpose grease.

Lubricate all grease fittings with a multi-purpose grease. For grease locations, refer to the lubrication chart in Section H.

EVERY 40 HOURS OF OPERATION

Check hydraulic reservoir fluid level. If oil is low, check all lines, fittings, and control valve for signs of leakage.

IMPORTANT: Hydraulic fluid level should be checked with backhoe in transport position.

WARNING! Escaping hydraulic/diesel fluid under pressure can penetrate the skin causing serious injury.



DO NOT use your hand to check for leaks. Use a piece of cardboard or paper to search for leaks.

Stop engine and relieve pressure before connecting or disconnecting lines.

Tighten all connections before starting engine or pressurizing lines.

If any hydraulic/diesel fluid is injected into the skin, obtain medical attention immediately or gangrene or other serious injury will result.

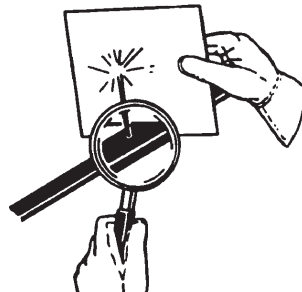

Physically check all pins, bushings, cotter pins, nuts, etc., for signs of wear or loose fit. Tighten as required, replacing where necessary. (Bolts and pins may vibrate loose during operation.) Clean equipment of all dirt, oil, and excess grease. This will assist you in making visual inspections and help avoid overlooking worn or damaged components.

6748

1-11-02-2

MAINTENANCE

GENERAL MAINTENANCE

CONTROL VALVE

The hydraulic control valve maintenance is normally limited to replacement of O-ring seals, cleaning and the replacement of valve sections or relief valve cartridges.

The most common cause of premature wear and malfunctioning of hydraulic system components is the ingress of contaminants and incorrect high pressure inlet and low pressure return connections (cavitation).

Observe a high standard of cleanliness when doing valve maintenance.

REPLACING BUCKET TOOTH POINTS

The bucket teeth are self-sharpening and require little attention: however, the points on the bucket teeth shanks can be replaced when they become worn or broken.

A tooth point can be removed from the welded tooth shank by removing the roll pin and sliding the tooth point off of the shank. Install the new point and secure in place with the roll pin.

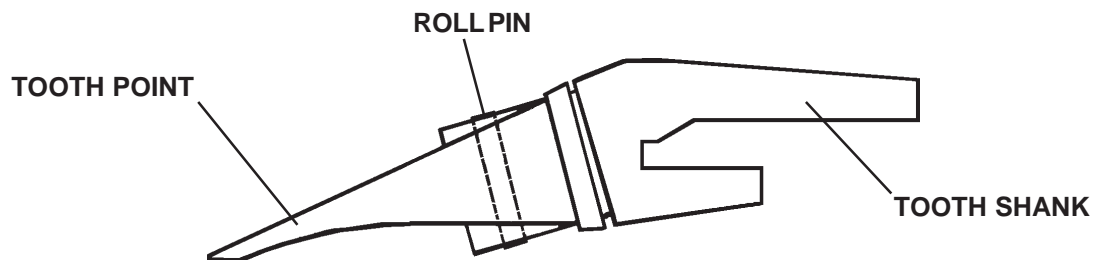

CHANGING BUCKETS

The bucket is connected to the dipper and bucket link with two cotter pin style pins. To change buckets, remove the cotter pins and washers and then remove the old bucket and position the new bucket in its place. Install the pivot pins and secure with washers and cotter pins. Lubricate all bucket and bucket link grease fittings before operating.

NOTE: Dipper Link must be installed with the with the pin containing the grease zerks at the dipper end and angled as shown in the diagram.

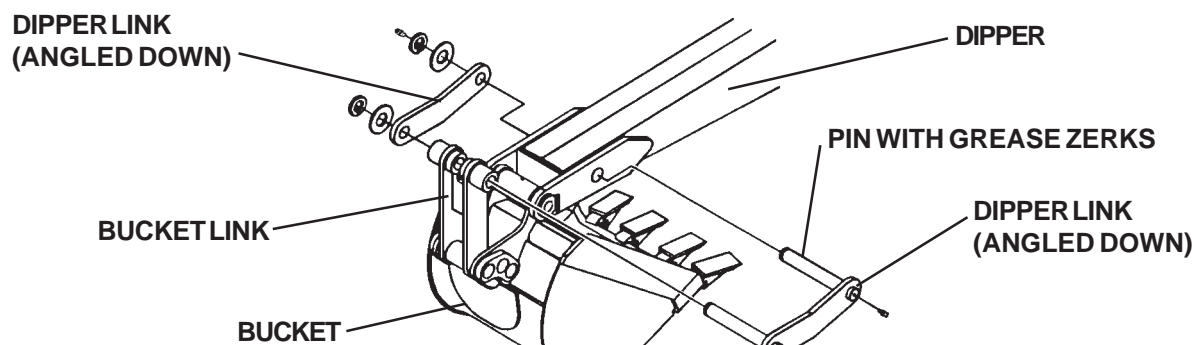

MAINTENANCE

POWER DIG BUCKETS

DIGGING POSITIONS

Power dig buckets may be installed in any one of three different digging positions. By using the different pairs of bucket link mounting holes, digging characteristics of the backhoe can be changed to suit the working conditions.

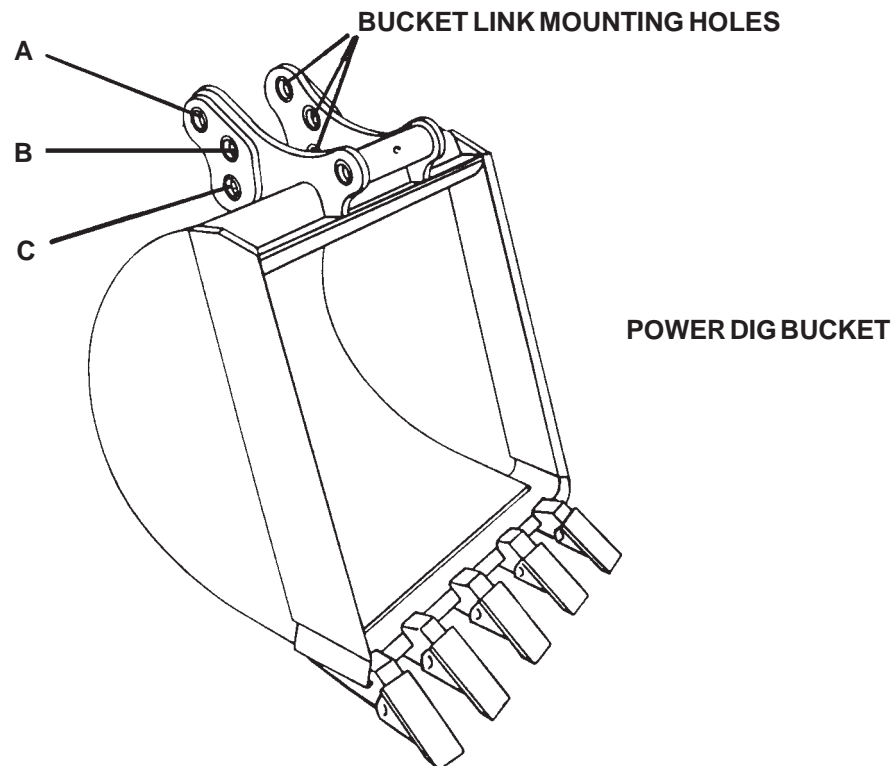

- "A" Position A is the power digging position for maximum digging force in hard ground. This position will give you a 20 percent increase in digging power over the standard position.
- "B" Position B is the truck loading position. It gives greater ease of spoil removal with a higher dump height than the standard or power dig position.
- "C" Position C is the standard digging position. When the bucket is mounted in this position, it will have 180° of rotation.

Digging positions are easily changed by removing the bucket link pivot pin from the bucket. Realign the hole in the bucket link with the correct holes in the bucket for the desired results. Install the pivot pin and secure it with the original washers and cotter pins and you're ready to go.

A special bell hole link is required to achieve a true bell hole position. This part is available from your dealer.

6895
3-8-96

HOSE ROUTING - 609 & 611 POWER BACKHOES

GENERAL INFORMATION

The purpose of this page is to show the hydraulic hose routing between the backhoe control valve and the various backhoe hydraulic cylinders. This information is helpful when trouble shooting cylinder and control valve related problems. Simply match the number of the hydraulic cylinder port (shown in the bottom diagram), to the corresponding number on the backhoe control valve (shown in the top diagram).

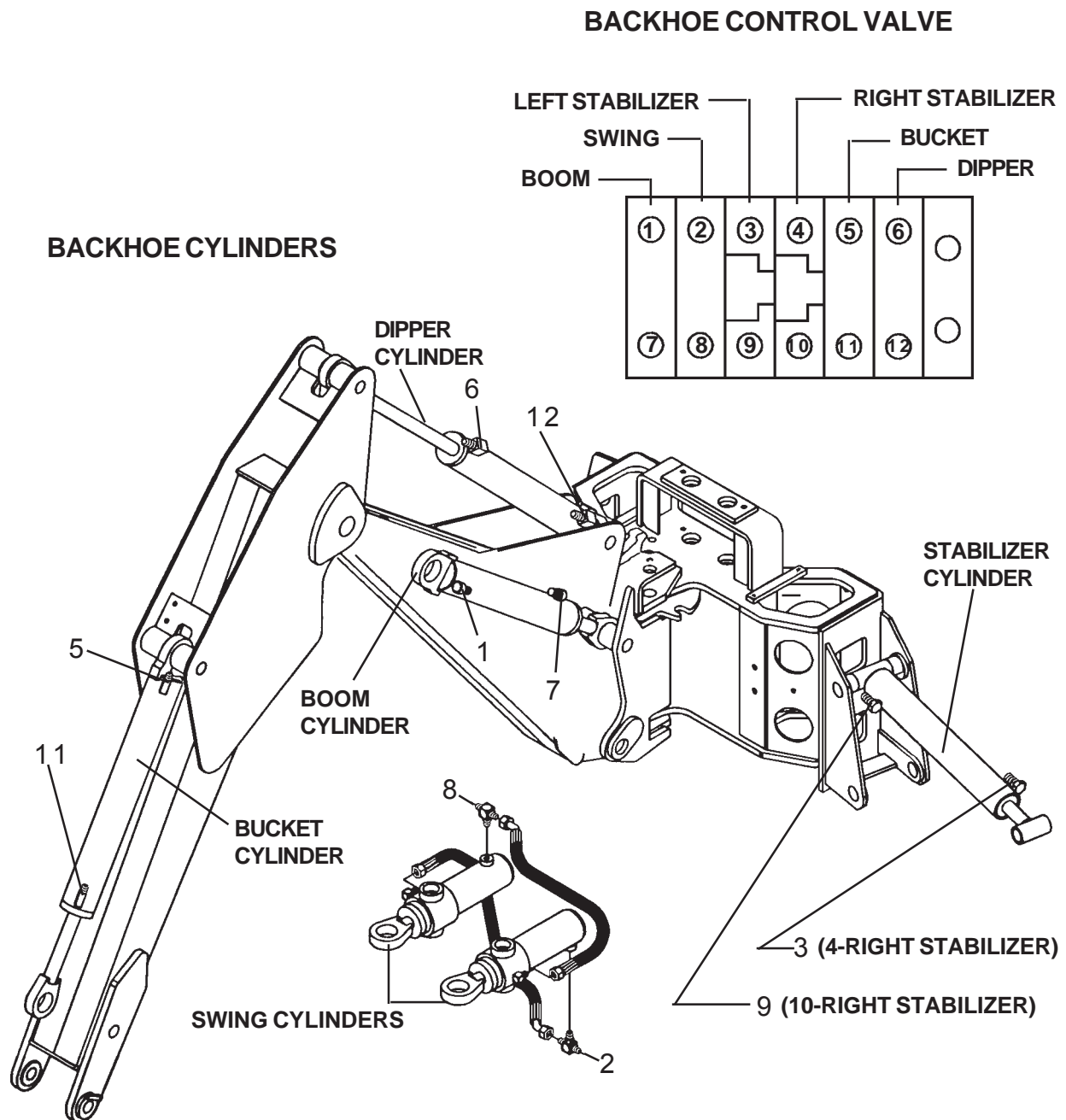

MAINTENANCE INSTRUCTIONS

CYLINDER SEAL REPLACE

GENERAL INFORMATION

The following information is provided to assist you in the event you should need to repair or rebuild a hydraulic cylinder. When working on hydraulic cylinders, make sure that the work area and tools are clean and free of dirt to prevent contamination of the hydraulic system and damage to the hydraulic cylinders. Always protect the active part of the cylinder rod (the chrome section). Nicks or scratches on the surface of the rod could result in cylinder failure. Clean all parts thoroughly with a cleaning solvent before reassembly.

DISASSEMBLY PROCEDURE

IMPORTANT: Do not contact the active surface of the cylinder rod with the vise. Damage to the rod could result.

RETAINING RING TYPE GLAND

1. Mount the cylinder tube securely in a vise. **CAUTION:** Do not clamp too tight and distort the tube.

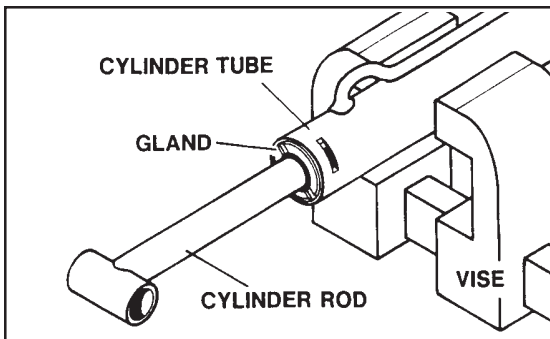

2. Rotate the gland with a spanner wrench (available from your dealer) until the gland retaining ring appears in the milled slot.

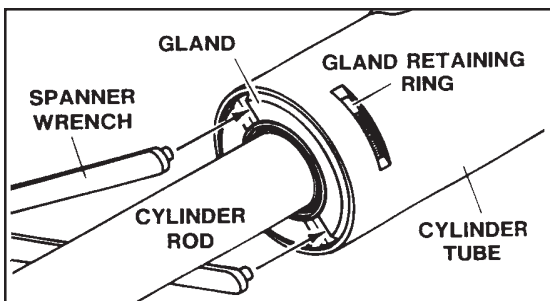

Pry up the end of the gland retaining ring with a pointed tool. Rotate the

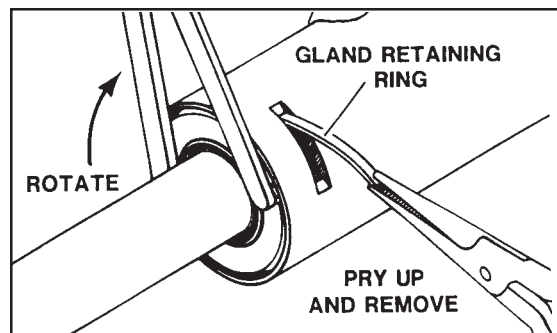

gland with a spanner wrench while removing the retaining ring.

NOTE: On cylinders with gland retaining rings, the gland and piston seal(s) can be pulled out and cut as they appear in the milled slot during disassembly. After cutting, pull them on out through the milled slot.

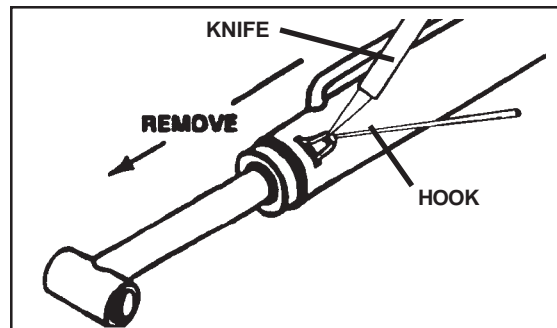

MAINTENANCE INSTRUCTIONS

CYLINDER SEAL REPLACE

3. Pull the cylinder rod from the cylinder tube.

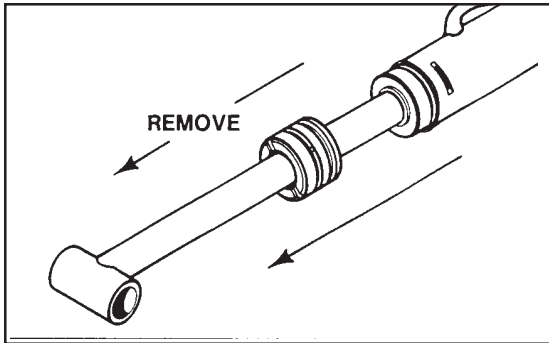

4. Inspect the piston and the bore of the cylinder tube for deep scratches or galling. If damaged, the piston and cylinder tube must be replaced.

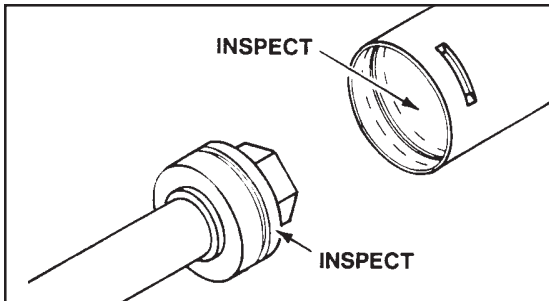

5. Remove the hex nut, piston, flat washer or spacer tube (if so equipped), and gland from the cylinder rod.

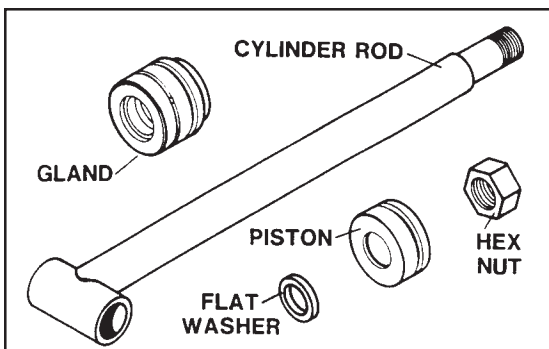

6. Remove and discard all old seals.

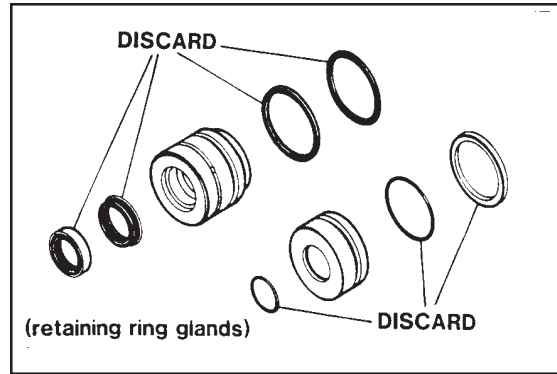

THREADED TYPE GLAND

1. Rotate the gland with a spanner wrench counter-clockwise until the gland is free of the cylinder tube.

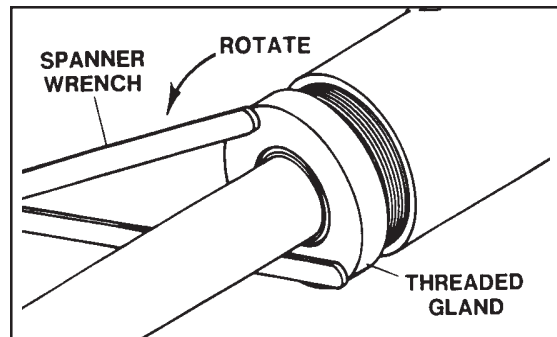
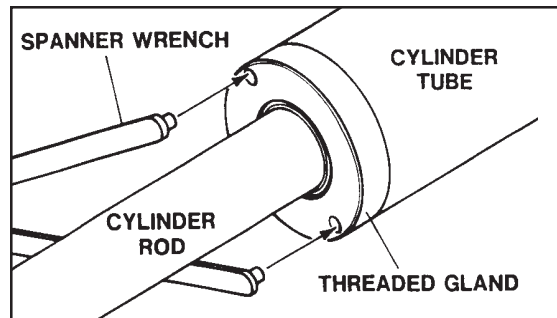

2. Pull the cylinder rod from the cylinder tube same as shown with the retaining ring type gland.

MAINTENANCE INSTRUCTIONS

CYLINDER SEAL REPLACE

3. Inspect the piston and the bore of the cylinder tube for deep scratches or galling. If damaged, the piston and cylinder tube must be replaced.

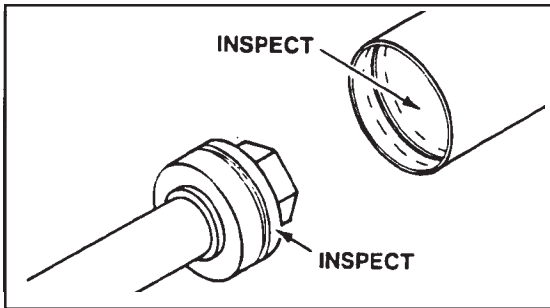

4. Remove the hex nut, piston, flat washer or spacer tube (if so equipped), and gland from the cylinder rod. If the cylinder rod is rusty, scratched, or bent, it must be replaced.

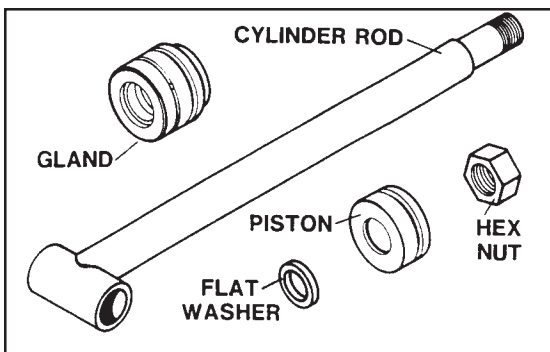

5. Remove and discard all the old seals.

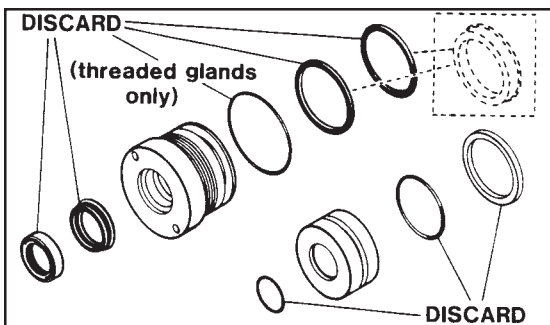

ASSEMBLY PROCEDURE

GENERAL

IMPORTANT: Replace all seals even if they do not appear to be damaged. Failure to replace all seals may result in premature cylinder failure.

1. Install the cylinder rod seal in the gland first. Be careful not to damage the seal in the process as it is somewhat difficult to install.

A special installation tool is available to help with installing the seal. Simply fit the end of the tool over the seal so that the large prong of the tool is on the outside of the seal, and the two smaller prongs on the inside. The lip of the seal should be facing towards the tool.

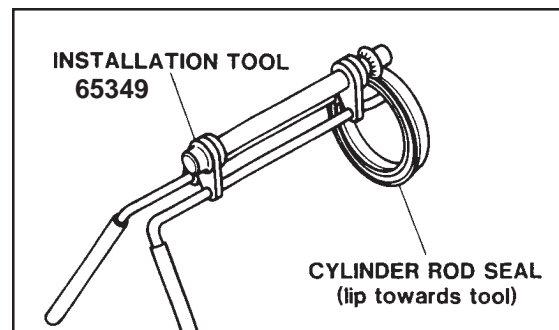

Rotate the handles on the tool around to wrap the seal around the end of the tool.

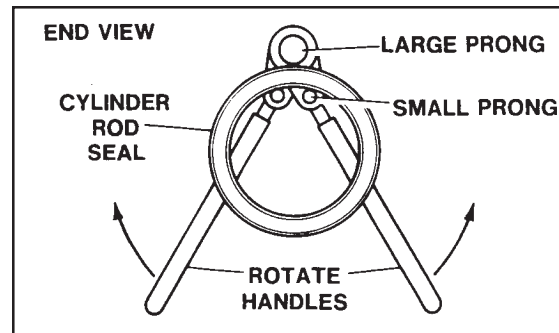

MAINTENANCE INSTRUCTIONS

CYLINDER SEAL REPLACE

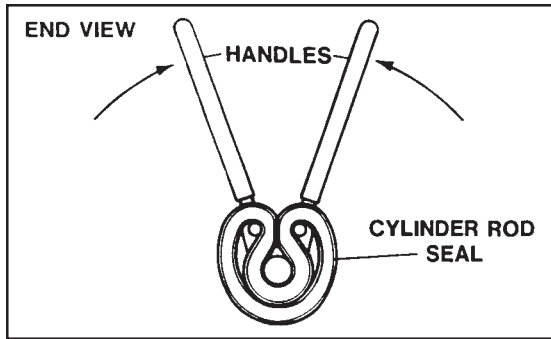

Now insert the seal into the gland from the inner end. Position the seal in its groove, and release and remove the tool. Press the seal into its seat the rest of the way by hand.

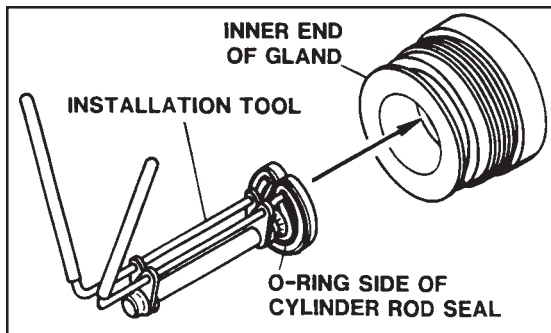

NOTE: Threaded gland is shown above for reference.

2. Install the new piston ring, rod wiper, O-rings, and backup washers, if applicable, on the piston.

Be careful not to damage the seals. Caution must be used when installing the piston ring. The ring must be stretched carefully over the piston with a smooth, round, pointed tool.

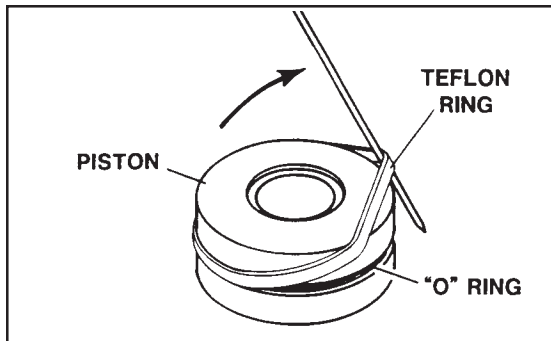

RETAINING RING TYPE GLAND

1. After installing the internal gland seal, install the external O-ring and backup washer.

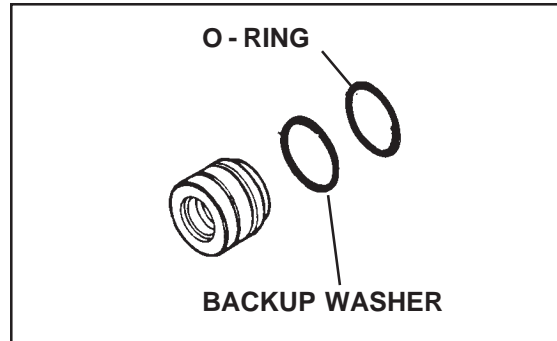

2. Slide the gland onto the cylinder rod being careful not to damage the rod wiper. Then install the spacer, or flat washer (if so equipped), small O-ring, piston, and hex nut onto the end of the cylinder rod.

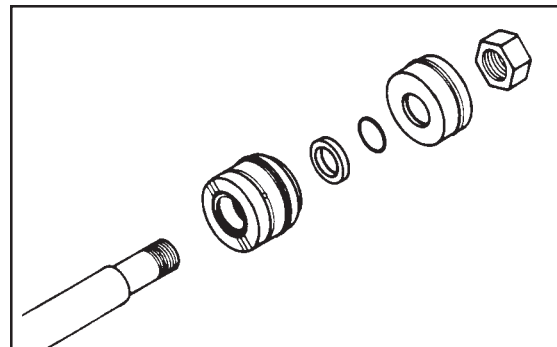

3. Secure the cylinder rod (mounting end) in a vise, with a support at its center. Torque the nut to the amount

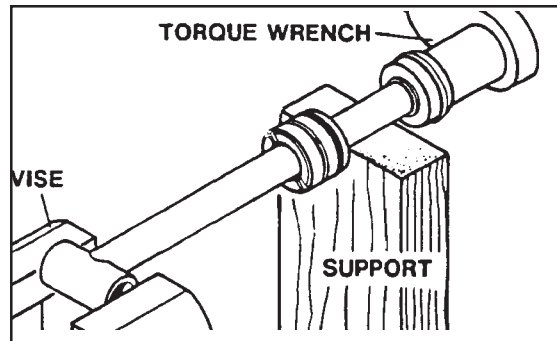

MAINTENANCE INSTRUCTIONS

CYLINDER SEAL REPLACE

shown on the chart for the thread diameter of the cylinder rod.(see chart)
IMPORTANT: Do not contact the active surface of the cylinder rod with the vise. Damage to the rod could result.

4. Apply a lubricant (such as Lubriplate #105) to the piston and teflon ring. Insert the cylinder rod assembly into the cylinder tube.

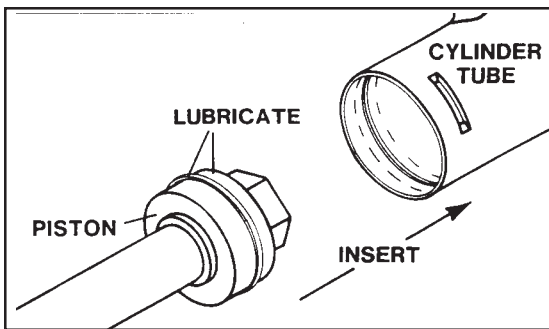

IMPORTANT: Ensure that the piston ring fits squarely into the cylinder tube and piston groove, otherwise the ring may be damaged and a leak will occur.

5. Rotate the gland with a spanner wrench until the hole (drilled into the retaining slot of the gland) appears in the milled slot of the cylinder tube. Insert the hooked end of the gland retaining rod into the hole.

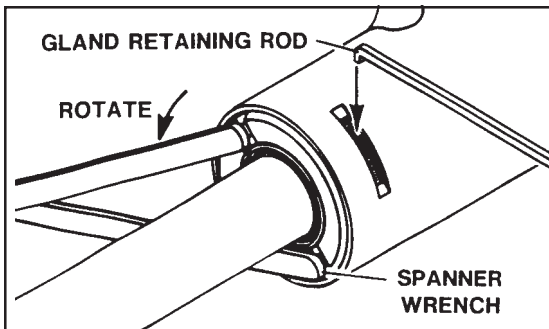

Rotate the gland until the gland retaining rod forms a ring between the gland and the cylinder tube.

When complete, the bent end of the gland retainer ring should be hidden (not turned so it is exposed in the slot) to prevent it from popping out.

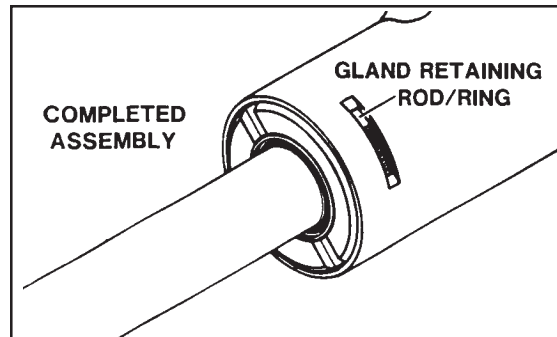

THREADED TYPE GLAND

1. After installing the rod seal inside the gland as shown in the general instructions, install the external seal.

NOTE: Threaded glands may have been equipped with a separate O-ring and backup washer system or a polypak (all-in-one) type seal. Current seal kits contain a polypak (all-in-one) type seal to replace the discarded seal types on all threaded glands.

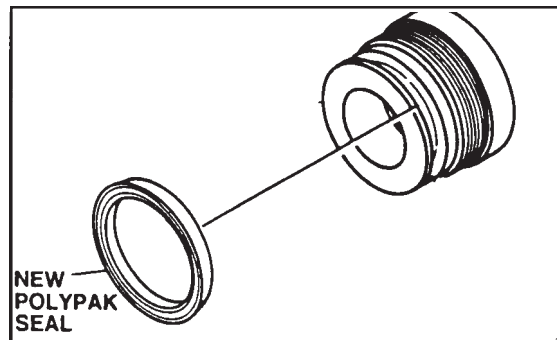

MAINTENANCE INSTRUCTIONS

CYLINDER SEAL REPLACE

2. Slide the gland onto the cylinder rod being careful not to damage the rod wiper. Then install the spacer, or flat washer (if so equipped), small O-ring, piston, and hex nut onto the end of the cylinder rod.

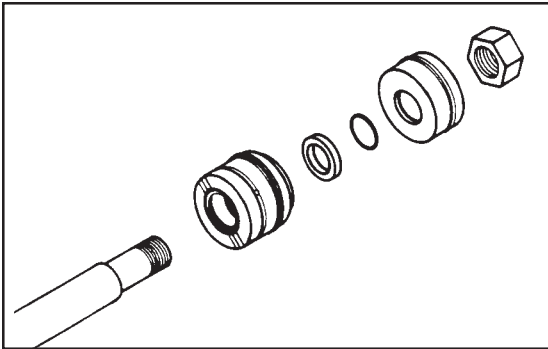

3. Secure the cylinder rod (mounting end) in a vise, with a support at its center. Torque the nut to the amount shown for the thread diameter of the cylinder rod (see chart).

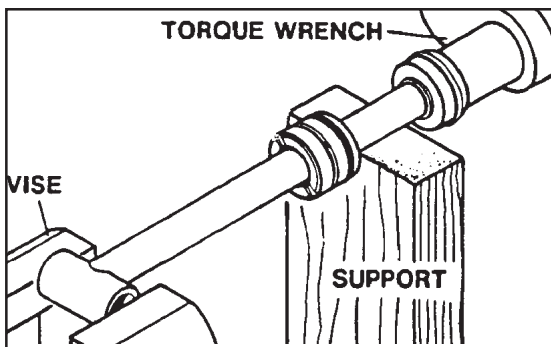

IMPORTANT: Do not contact the active surface of the cylinder rod with the vise. Damage to the rod could result.

4. Apply a lubricant (such as Lubriplate #105) to the piston and teflon ring. Insert the cylinder rod assembly into the cylinder tube.

IMPORTANT: Ensure that the piston ring fits squarely into the cylinder tube and piston groove, otherwise the ring may be damaged and a leak will occur.

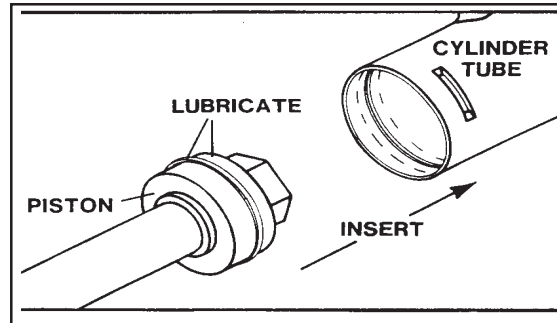

5. Use a spanner wrench to rotate the gland clockwise into the cylinder. Continue to rotate the gland with the spanner wrench until it is tight.

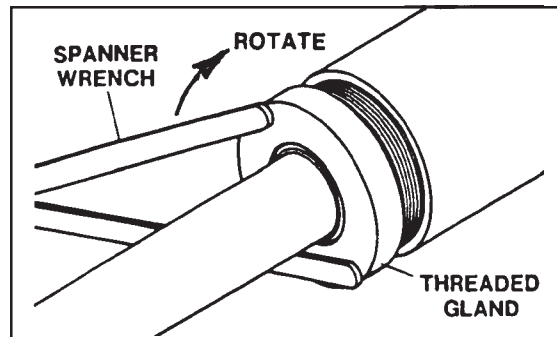

NOTE: Seal kits will service all backhoe cylinders of similar bore size and rod diameter.

WARNING! Cylinders serviced in the field are to be tested for leakage prior to the hoe being placed in work.



Failure to test rebuilt cylinders could result in damage to the cylinder and/or backhoe, cause severe personal injury, or even death.

MAINTENANCE INSTRUCTIONS

CYLINDER SEAL REPLACE

TORQUE SPECIFICATION CHART

Use the following torque values when tightening the nuts on the cylinder rod threads.

Thread Diameter	POUNDS - FEET	
	Minimum	Maximum
7/8 "	150	200
* 1 "	230	325
1-1/8 "	350	480
1-1/4 "	490	670
1-3/8 "	670	900

* 1" Thread Diameter WITH 1.25" Rod Diameter Min. 230 ft. lbs. Max. 250 ft. lbs.

BACKHOE STORAGE

609 & 611 POWER BACKHOES

BACKHOE STORAGE

To prepare the backhoe for storage, first wash off all dirt and grime from the unit. Coat the exposed portions of the cylinder rods with grease. Lubricate all grease fittings. Make sure the backhoe hydraulic system is properly sealed against contaminants entering the unit. When storing the backhoes, place the unit in a clean dry place with a cover over the unit if possible.

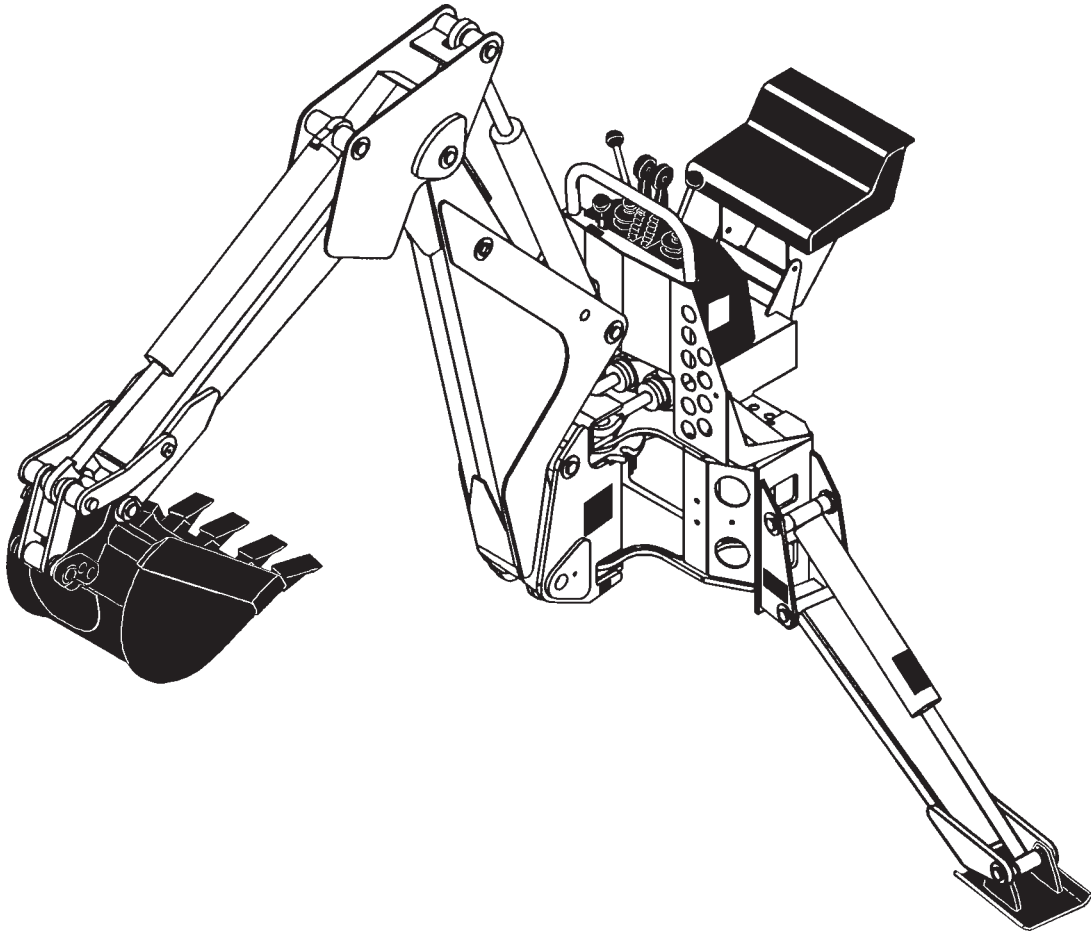

6888
9-14-04-2

PROBLEM	POSSIBLE CAUSE	REMEDY
Backhoe fails to lift or swing	Low oil supply	Add oil
	Improper hose hookup	Check hydraulic diagram; reinstall properly
	Worn control valve section	Replace section
	Pump damaged or worn	Replace pump
	Broken hydraulic line	Check for leaks and replace line
	Jammed swing linkage	Remove interference
	Bent cylinder rod	Replace or repair cylinder
	Swing speed control completely closed	Open swing speed control valve
Backhoe lifting or swinging too slowly	Cold oil	Warm oil with engine at idle speed
	Engine speed too slow	Open throttle
	Oil leaking past control valve	Replace or repair worn section
	Oil too heavy	Use recommended oil
	Pump damaged or worn	Replace or repair pump
	Oil leaking past cylinder packings	Replace packings
	Dirty oil filter	Replace filter
	Faulty relief valve	Clean or replace
Incorrect restrictors in valve	Check restrictor orifice size with those shown on valve assembly page	

TROUBLESHOOTING

PROBLEM	POSSIBLE CAUSE	REMEDY
Backhoe fails to hold up load	Broken or leaking lines	Replace broken hose and check for leaks
	Dirty oil	Drain and refill oil, replace filter
	Oil leaking past cylinder packings	Replace packings
	Oil leaking past control valve	Replace or repair worn section
	Faulty relief valve	Clean or replace
Oil heating	Dirty oil	Drain and refill oil, replace filter
	Air entering suction line to pump	Eliminate leaks
	Partially plugged inlet filter	Clean filter element
	Control valve held open too long	Return control to neutral position when not in use
	Worn pump	Replace pump
	Relief valve set too low	Set valve correctly
	Oil too light in hot weather	Use recommended oil
	Engine running too fast	Reduce throttle
	Damaged oil lines	Replace damaged lines
Poor operating technique causing excessive oil flow over relief valve	Learn smooth operating methods	

PROBLEM	POSSIBLE CAUSE	REMEDY
External leakage	Control valve tie bolts loose	Torque bolts to 20 ft.lbs.
	Damaged O-rings between valve sections	Repair control valve
	Damaged O-rings on valve spools	Repair control valve
	Cylinder seals damaged	Repair cylinder
	Damaged O-rings on valve drop check	Repair control valve
	Broken oil lines	Replace hose and check for leaks
Swing cylinder malfunctioning	Oil leaking past packing or seals	Replace packing or seals
	Faulty relief valve	Clean or replace
Control valve sticking or working hard	Dirty valve	Clean valve
	Scored bore or bent spool	Replace valve section
	Control linkage misaligned	Correct misalignment
	Control valve tie bolts too tight	Tighten bolts only to 20 ft.lbs.
	Return spring binding or broken	Replace spring
	Foreign matter in spool bore	Clean valve



BOLT TORQUE

BOLT TORQUE SPECIFICATIONS

GENERAL TORQUE SPECIFICATION TABLE

Use the following torques when special torques are not given. These values apply to fasteners as received from suppliers, dry, or when lubricated with normal engine oil. They do not apply if special graphited or moly disulphide greases or other extreme pressure lubricants are used. This applies to both UNF and UNC threads. Remember to always use grade five or better when replacing bolts.

SAE Grade No.		2				5				8*			
Bolt head identification marks as per grade. NOTE: Manufacturing Marks Will Vary													
		TORQUE		TORQUE		TORQUE		TORQUE		TORQUE		TORQUE	
Bolt Size		Pounds Feet		Newton-Meters		Pounds Feet		Newton-Meters		Pounds Feet		Newton-Meters	
Inches	Millimeters	Min.	Max.	Min.	Max.	Min.	Max.	Min.	Max.	Min.	Max.	Min.	Max.
1/4	6.35	5	6	6.8	8.13	9	11	12.2	14.9	12	15	16.3	30.3
5/16	7.94	10	12	13.6	16.3	17	20.5	23.1	27.8	24	29	32.5	39.3
3/8	9.53	20	23	27.1	31.2	35	42	47.5	57.0	45	54	61.0	73.2
7/16	11.11	30	25	40.7	47.4	54	64	73.2	86.8	70	84	94.9	113.9
1/2	12.70	45	52	61.0	70.5	80	96	108.5	130.2	110	132	149.2	179.0
9/16	14.29	65	75	88.1	101.6	110	132	149.2	179.0	160	192	217.0	260.4
5/8	15.88	95	105	128.7	142.3	150	180	203.4	244.1	220	264	298.3	358.0
3/4	19.05	150	185	203.3	250.7	270	324	366.1	439.3	380	456	515.3	618.3
7/8	22.23	160	200	216.8	271.0	400	480	542.4	650.9	600	720	813.6	976.3
1	25.40	250	300	338.8	406.5	580	696	786.5	943.8	900	1080	1220.4	1464.5
1-1/8	25.58	-	-	-	-	800	880	1084.8	1193.3	1280	1440	1735.7	1952.6
1-1/4	31.75	-	-	-	-	1120	1240	1518.7	1681.4	1820	2000	2467.9	2712.0
1-3/8	34.93	-	-	-	-	1460	1680	1979.8	2278.1	2380	2720	3227.3	3688.3
1-1/2	38.10	-	-	-	-	1940	2200	2630.6	2983.2	3160	3560	4285.0	4827.4

* Thick Nuts must be used with Grade 8 bolts

METRIC BOLT TORQUE SPECIFICATIONS

Size of Screw	Grade No.	Coarse Thread			Fine Thread		
		Ptich (mm)	Pounds Feet	Newton-Meters	Pitch (mm)	Pounds Feet	Newton-Meters
M6	5.6	1.0	3.6-5.8	4.9-7.9	-	-	-
	8.8		5.8-9.4	7.9-12.7		-	-
	10.9		7.2-10	9.8-13.6		-	-
M8	5.6	1.25	7.2-14	9.8-19	1.0	12-17	16.3-23
	8.8		17-22	23-29.8		19-27	25.7-36.6
	10.9		20-26	27.1-35.2		22-31	29.8-42
M10	5.6	1.5	20-25	27.1-33.9	1.25	20-29	27.1-39.3
	8.8		34-40	46.1-54.2		35-47	47.4-63.7
	10.9		38-46	51.5-62.3		40-52	54.2-70.5
M12	5.6	1.75	28-34	37.9-46.1	1.25	31-41	42-55.6
	8.8		51-59	69.1-79.9		56-68	75.9-92.1
	10.9		57-66	77.2-89.4		62-75	84-101.6
M14	5.6	2.0	49-56	66.4-75.9	1.5	52-64	70.5-86.7
	8.8		81-93	109.8-126		90-106	122-143.6
	10.9		96-109	130.1-147.7		107-124	145-168
M16	5.6	2.0	67-77	90.8-104.3	1.5	69-83	93.5-112.5
	8.8		116-130	157.2-176.2		120-138	162.6-187
	10.9		129-145	174.8-196.5		140-158	189.7-214.1
M18	5.6	2.0	88-100	119.2-136	1.5	100-117	136-158.5
	8.8		150-168	203.3-227.6		177-199	239.8-269.6
	10.9		175-194	237.1-262.9		202-231	273.7-313
M20	5.6	2.5	108-130	146.3-176.2	1.5	132-150	178.9-203.3
	8.8		186-205	252-277.8		206-242	279.1-327.9
	10.9		213-249	288.6-337.4		246-289	333.3-391.6

3915
6-8-95-2

SPECIFICATIONS

609 & 611 POWER BACKHOES

BACKHOE DIMENSIONS

SPECIFICATIONS AND DESIGN ARE SUBJECT TO CHANGE WITHOUT NOTICE AND WITHOUT LIABILITY THEREFORE. WHENEVER APPLICABLE SPECIFICATIONS ARE IN ACCORDANCE WITH SAE STANDARDS.

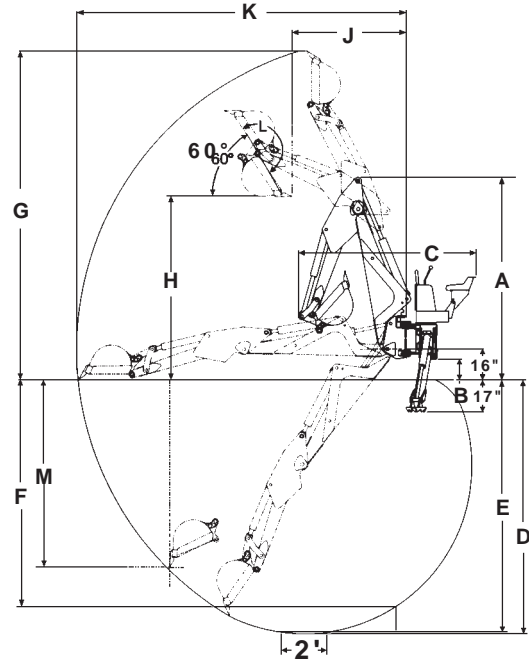

BACKHOE SPECIFICATION TABLE

DESCRIPTION	609	611
TRANSPORT		
A Transport Height (with boom fully retracted)	7'9"	8'10"
Transport Width (with stabilizers up)	4'9"	4'9"
B Ground Clearance	11"	11"
C Overall Length	7'7"	7'9"
Boom Pivot Height	16"	16"
Operating Weight w/12" Bucket	1702#	1847#
OPERATIONAL		
D Digging Depth Maximum	9'8"	11'1"
E Digging Depth (2 Ft.) Flat Bottom	9'7"	11'0"
F Digging Depth (8Ft.) Flat Bottom	8'3"	9'11"
G Overall Operating Height - Fully Raised	12'10"	14'5"
H Loading Height	6'10"	8'0"
J Loading Reach	4'2"	5'0"
K Reach From Swing Post	12'10"	14'5"
L Bucket Rotation	180°	180°
Swing Arc	180°	180°
M Straight Wall Digging Depth	7'3"	8'2"
Stabilizer Spread Operating Position	9'11"	9'11"
Stabilizer Down Below Grade	17"	17"
System Relief Valve Setting	2500 PSI	2500PSI
Digging Force - Bucket Cylinder	5908#	6167#
Digging Force - Dipper Cylinder	3232#	4160#

SPECIFICATIONS

CYLINDER AND BUCKET SPECIFICATIONS 609 & 611 POWER BACKHOES

CYLINDER SPECIFICATION TABLE

CYLINDER	609	611
BUCKET CYLINDER		
Cylinder #	82477	82477
Bore	3.00"	3.00"
Stroke	18.38"	18.38"
Rod Diameter	2.00"	2.00"
DIPPER CYLINDER		
Cylinder #	85782	85779
Bore	3.25"	3.50"
Stroke	21.38"	26.75"
Rod Diameter	1.75"	1.75"
BOOM CYLINDER		
Cylinder #	82625	82476
Bore	3.00"	3.50"
Stroke	24.83"	24.83"
Rod Diameter	1.50"	1.75"
SWING CYLINDER		
Cylinder #	81022	81022
Bore	2.75"	2.75"
Stroke	7.65"	7.65"
Rod Diameter	1.25"	1.25"
STABILIZER CYLINDER		
Cylinder #	82980	82980
Bore	3.00"	3.00"
Stroke	18.93"	18.93"
Rod Diameter	1.50"	1.50"

POWER DIG BUCKETS AND CAPACITIES

Bucket Size	Struck Cap. Ft. ³	Heaped Cap. Ft. ³	Weight Lbs.	Number Of Teeth
Standard 12"	1.43	1.83	125	3
Standard 16"	1.98	2.56	139	4
Standard 18"	2.25	2.98	147	4
Standard 20"	2.52	3.40	153	4
Standard 24"	3.07	4.32	170	5
Severe Duty 12"	1.43	1.83	125	3
Severe Duty 16"	1.98	2.56	139	4
Severe Duty 18"	2.25	2.98	147	4
Severe Duty 20"	2.52	3.40	153	4
Severe Duty 24"	3.07	4.32	170	5

DECALS

DECAL PLACEMENT

GENERAL INFORMATION

The diagrams on this page shows the location of all the decals used on the 609 and 611 backhoes. The decals are identified by their part numbers, with reductions of the actual decals located on the following pages. Use this information to order replacements for lost or damaged decals. Be sure to read all decals before operating the backhoe. They contain information you need to know for both safety and backhoe longevity.

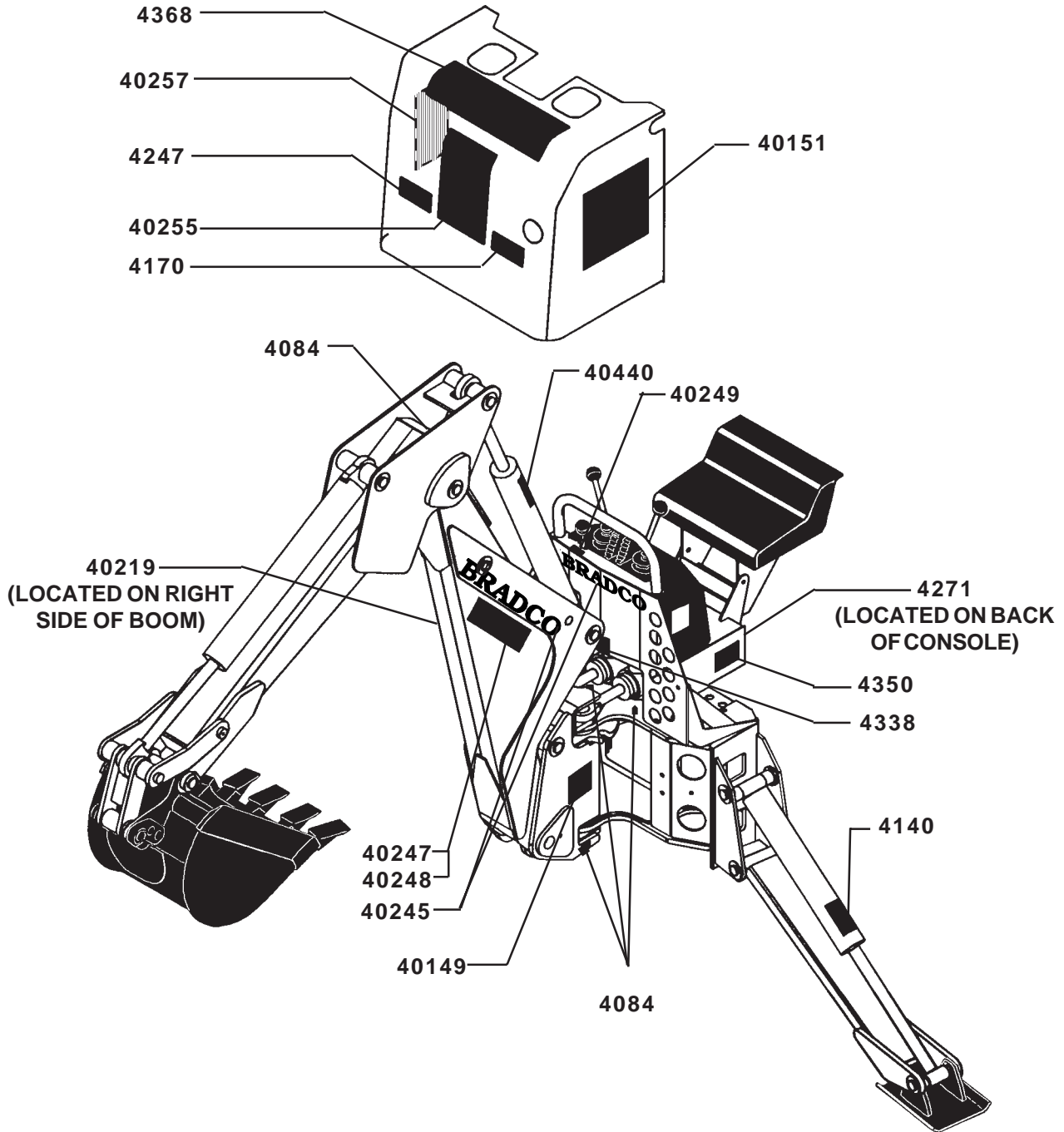

DECALS

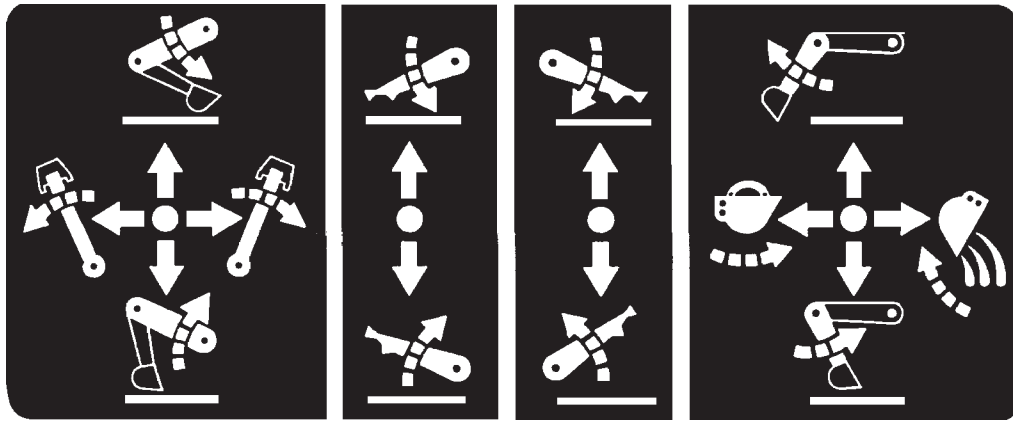

PART #4368
OPERATING CONTROLS DECAL

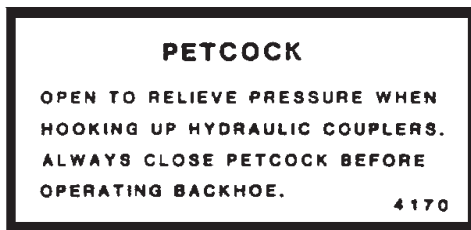

PART #4170
PETCOCK OPERATION DECAL

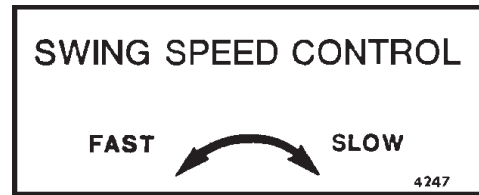

PART #4247
SWING SPEED CONTROL DECAL

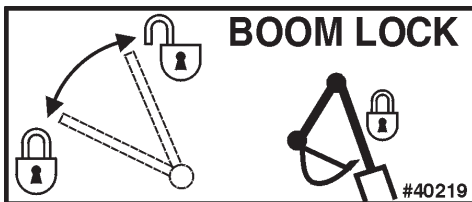

PART #40219
BOOM LOCK DECAL

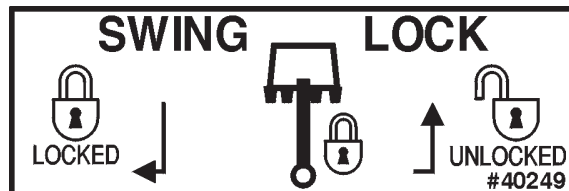

PART #40249
SWING LOCK DECAL

DECALS

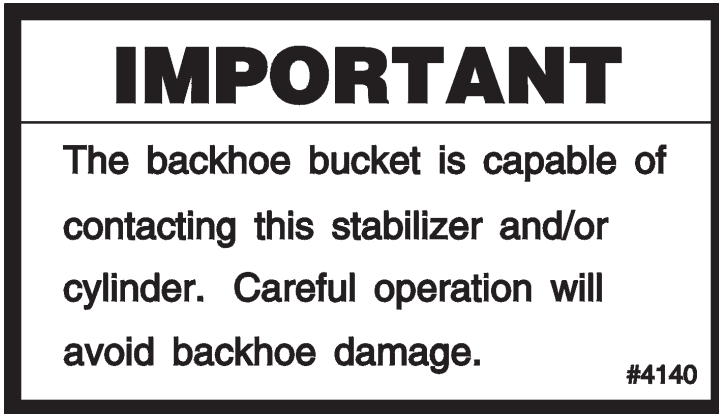

PART #4140
BUCKET CONTACT WARNING DECAL



PART #4338
MADE IN U.S.A. DECAL



PART #40440
CALL BEFORE YOU DIG

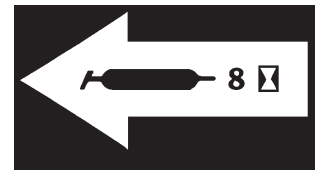

PART #4084
GREASE 8 HOURS



PART #40151
HIGH PRESSURE FLUID DECAL

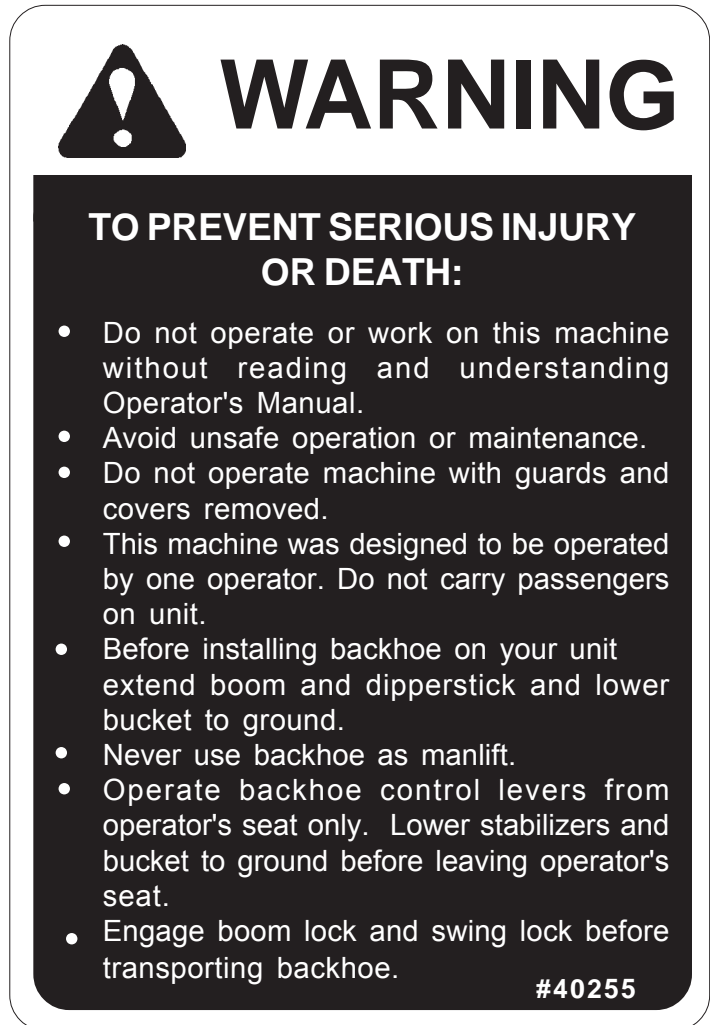

PART #40255
OPERATIONAL WARNING DECAL

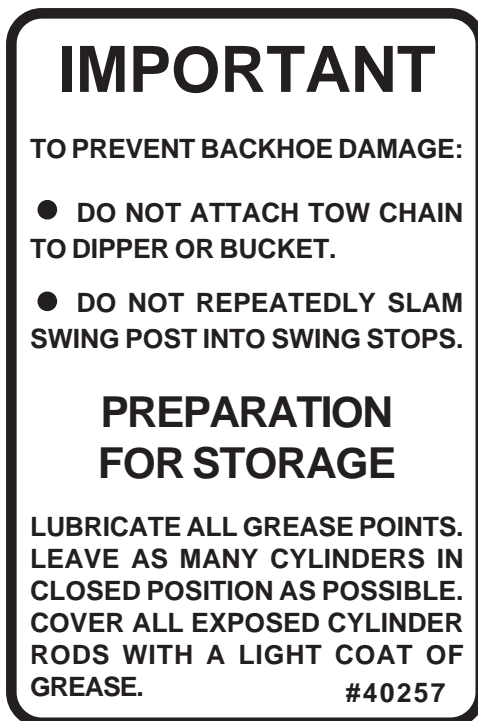

PART #40257
IMPORTANT! DECAL



PART #40149
DANGER! PINCH POINTS

BRADCO®

PART #40245 (3 REQ'D)
BRADCO LOGO - SILBER

609

PART #40247 (2 REQ'D)
609 MODEL NUMBER

611

PART #40248 (2 REQ'D)
611 MODEL NUMBER

SERVICE INFORMATION

#4271

THIS IS AN INLINE 90 MICRON SINTERED BRONZE FILTER. IF PLUGGED OR PARTIALLY FILLED IT WILL REDUCE BACKHOE PERFORMANCE. REMOVE AND WASH OUT REGULARLY. REPLACE ELEMENT #45133 IF DIFFICULT TO BLOW THROUGH AFTER WASHING. SEE FULL INSTRUCTIONS IN OWNERS MANUAL.

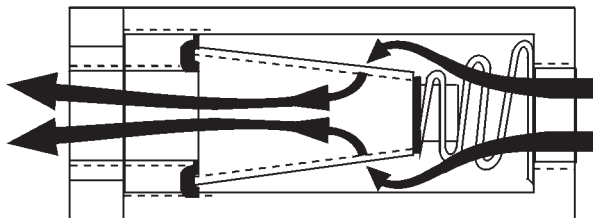

PART #4271
INLINE FILTER DECAL

6858
4-29-04-2

PRE-DELIVERY CHECKLIST

GENERAL INFORMATION

The following is a list of areas that should be inspected by the dealer prior to delivery of the backhoe to the customer. The customer should check the list and make sure that the dealer has completed the inspection. Completion of this check list will help insure that the customer receives the backhoe in complete working order, ready to install.

PRE-DELIVERY CHECKLIST - CHECK AND ADJUST AS NECESSARY

1. _____ Check the hydraulic system for correct hydraulic fluid level.
2. _____ Check and lubricate backhoe if necessary. See "Lubrication", Section H.
3. _____ Visually inspect the backhoe for bent, loose, cracked, damaged or missing parts. Check for any other irregularities.
4. _____ Remove paint from finished (chrome) surfaces of cylinders and valve spools.
5. _____ Backhoe control levers function and direction of operation are in accordance with the control lever decals.
6. _____ Run cylinders through their full cycle to purge any air from the system.
7. _____ Check all hydraulic connections for leaks and all hoses for proper positioning to reduce chafing and binding.
8. _____ Check system relief valve pressure and compare and adjust to recommended operating pressure listed in the "Specifications". See Section P.
9. _____ Check backhoe attachment bolts for tightness. Retighten after the first eight working hours, and after every forty working hour interval thereafter. See "Bolt Torque", Section O.
10. _____ Make sure decals are not damaged or missing and are in their right location. See "Decals", Section Q.
11. _____ Complete and return the manufacturers "Warranty Validation Form" and sign your dealership pre-delivery checklist.
12. _____ Operator to read the E.M.I. Loader/Backhoe safety manual provided before operating backhoe.

LIMITED WARRANTY

EFFECTIVE ON PRODUCTS MANUFACTURED AFTER JANUARY 1, 2001

All new BRADCO products are warranted to be free from defects in materials or workmanship which may cause failure under normal usage and service when used for the purpose intended.

In the event of failure within twenty four (24) months from initial retail sale, lease or rental date (excluding cable, ground engaging parts such as sprockets, digging chain, bearings, teeth, tamping and demolition heads, blade cutting edges, pilot bits, auger teeth, auger heads & broom bristles), if after examination, BRADCO determines failure was due to defective material and/or workmanship, parts will be repaired or replaced. BRADCO may request defective part or parts be returned prepaid to them for inspection at their place of business at Delhi, Iowa, or to a location specified by BRADCO.

Any claims under this warranty must be made within fifteen (15) days after the Buyer learns of the facts upon which such claim is based. All claims not made in writing and received by BRADCO within the time period specified above shall be deemed waived.

THIS WARRANTY IS IN LIEU OF ALL OTHER WARRANTIES EXPRESSED OR IMPLIED AND THERE ARE NO WARRANTIES OF MERCHANTABILITY OR OF FITNESS FOR A PARTICULAR PURPOSE. IN NO EVENT SHALL BRADCO BE LIABLE FOR CONSEQUENTIAL OR SPECIAL DAMAGE.

BRADCO'S LIABILITY FOR ANY AND ALL LOSSES AND DAMAGES TO BUYER, RESULTING FROM ANY CAUSE WHATSOEVER, INCLUDING BRADCO'S NEGLIGENCE, IRRESPECTIVE OF WHETHER SUCH DEFECTS ARE DISCOVERABLE OR LATENT, SHALL IN NO EVENT EXCEED THE PURCHASE PRICE OF THE PARTICULAR PRODUCTS WITH RESPECT TO WHICH LOSSES OR DAMAGES ARE CLAIMED, OR, AT THE ELECTION OF BRADCO, THE REPAIR OR REPLACEMENT OF DEFECTIVE OR DAMAGED PRODUCTS.