



2415 & 3215 TREE SPADES

OPERATOR'S & PARTS MANUAL



PALADIN LIGHT CONSTRUCTION

ALL
APPLICATIONS



SERIAL NUMBER: _____

MODEL NUMBER: _____

Manual Number: OM632
Part Number: 75532
Rev. 2

TABLE OF CONTENTS

TO THE OWNER	A
SAFETY PRECAUTIONS	B
To the Operator	
Before You Start	
Working With The Attachment	
Transporting The Attachment	
Maintenance	
INTERNATIONAL SYMBOLS	C
PRE-OPERATION	D
Before Operating	
Blade Preparation	
Skid-Steer or Host Machine	
Major Nomenclature	
MOUNTING KITS AND ASSEMBLIES	E
2415 Tree Spade	
2415 Hydraulic Circuits	
3215 Tree Spade	
3215 Hydraulic Circuits	
Cylinder Assemblies	
Electrical Assembly	
Valve Assembly	
Solenoid Valve - Replacement Parts	
Wiring Schematics	
Blade Sets	
INSTALLATION INSTRUCTIONS	F
OPERATION INSTRUCTIONS	G
Controls	
General Information	
Adjusting Leg Height	
Balled and Burlapped Trees	
Direct Transplanting	
LUBRICATION	H
MAINTENANCE AND SERVICE	L
Preventive Maintenance	
Blade Maintenance	
Sharpening Blades and Undercutter	
Replacing Bushings	
Slide Channel Adjustment	
Cylinder Seal Replacement	
STORAGE AND TRANSPORTING	M
TROUBLESHOOTING	N
BOLT TORQUE SPECIFICATION	O
SPECIFICATIONS	P
DECALS	Q
PREDELIVERY CHECKLIST	R
LIMITED WARRANTY	S

TO THE OWNER

GENERAL COMMENTS

Congratulations on the purchase of your new BRADCO product! This product was carefully designed and manufactured to give you years of dependable service. Only minor maintenance (such as cleaning and lubricating) is required to keep it in top working condition. Be sure to observe all safety precautions and maintenance procedures, as described in this manual.

ABOUT THIS MANUAL

This manual has been designed to help you do a better, safer job. Read this manual carefully and become familiar with its contents. **Remember, never let anyone operate this unit without reading the "Safety Precautions" and "Operating Instructions" sections of this manual. (See Sections B and G respectively.)**

Unless noted otherwise, right and left sides are determined from the position of the operator when behind the product facing forward.

SAFETY ALERT SYMBOL



This is the "Safety Alert Symbol" used by this industry. This symbol is used to warn of possible injury. Be sure to read all warnings carefully. They are included for your safety and for the safety of others working with you.

SERVICE

When servicing your product, remember to use only manufacturer replacement parts. Substitute parts may not meet the standards required for safe, dependable operation.

To facilitate parts ordering, record the model and serial number of your unit in the space provided on this page. This information may be obtained from the identification plate located on the product.

MODEL _____
SERIAL NUMBER _____
DATE PURCHASED _____

The parts department needs this information to insure that you receive the correct parts for your specific model.

SAFETY PRECAUTIONS

TAKE NOTE! THIS SAFETY ALERT SYMBOL FOUND THROUGHOUT THIS MANUAL IS USED TO CALL YOUR ATTENTION TO INSTRUCTIONS INVOLVING YOUR PERSONAL SAFETY OR OTHERS. FAILURE TO FOLLOW THESE INSTRUCTIONS CAN RESULT IN INJURY OR DEATH.



THIS SYMBOL MEANS:

ATTENTION!

BECOME ALERT!

YOUR SAFETY IS INVOLVED!

SIGNAL WORDS: Note the use of signal words DANGER, WARNING, and CAUTION with the safety messages. The appropriate signal word for each has been selected using the following guidelines:

DANGER: Indicates an imminently hazardous situation, which if not avoided, will result in death or serious injury. This signal word is to be limited to the most extreme situations, **typically for machine components which, for functional purposes, cannot be guarded.**

WARNING: Indicates a potentially hazardous situation, which if not avoided, could result in death or serious injury, and **includes hazards that are exposed when guards are removed. It may also be used to alert against unsafe practices.**

CAUTION: Indicates a potentially hazardous situation, which if not avoided, **may result in minor or moderate injury. It may also be used to alert against unsafe practices.**

SAFETY PRECAUTIONS

GENERAL INFORMATION

This section is composed of various warnings and safety tips. **Read and learn all the information in this section before you attempt to use your attachment.** Also read your vehicle owner's manual before using your equipment. This knowledge will help you operate your unit safely. **Do not take this information lightly, it is presented for your benefit and for the benefit of others working around you.**

The "Safety Alert Symbol", as previously described, will be used throughout this manual. It will appear with the word **DANGER, WARNING, or CAUTION** above it, and a safety message pertaining to the specific topic being covered. Take the time to read these messages as you come across them.

TO THE OPERATOR

The primary responsibility for safety with the equipment falls to the operator. Make sure that the equipment is operated only by responsible individuals with the proper instruction. It is the skill, care, common sense, and good judgment of the operator that will determine how efficiently and safely the job is performed. Know your equipment before you start. Know its capabilities and how to operate all the controls. Visually inspect your equipment before you start, and never operate equipment that is not in proper working order.

BEFORE YOU START

1. **Read the entire loader and attachment operator's manuals** before ever attempting to use the loader. This knowledge is necessary for safe operation.
2. **Follow all safety decals.** Keep them clean, and replace them if they become worn, damaged, or illegible.
3. **Do not paint over,** remove, or deface any safety signs or warning decals on your equipment.
4. **Know your equipment inside and out.** Know how to operate all controls, and know emergency shut down procedures.
5. **Keep all stepping surfaces, pedals, and controls free from dirt, grease, and oil.** Keep equipment clean to help avoid injury from a fall when getting on or off equipment.
6. **Use handholds and step plates when getting on/off .** Failure to do so could cause a fall.
7. **Be alert to others in the work area.** Be sure others know when and where you will be working. Make sure no one is behind equipment.
8. **Never take passengers on your equipment.** There is no safe place for a passenger.

SAFETY PRECAUTIONS

9. **Never try to board equipment while it is moving.**
10. **Turn off engine before performing maintenance.** If lift arms must be left raised for maintenance or any other reason, use a positive lift arm lock to secure the arms in place. Serious damage or personal injury could result from lift arms accidentally lowering.
11. **Reduce speed when driving over rough terrain,** on a slope, or turning, to avoid overturning the loader.
12. **Test all controls before you begin.**
13. **Do not smoke when refueling.** Allow room in the gas tank for expansion. Wipe up any spilt fuel. Secure cap tightly when done.

WORKING WITH THE ATTACHMENT

1. **Never operate the unit without first reading and understanding the operator's manual.**
2. **Operate the attachment only in daylight or sufficient artificial light.**
3. **Do not carry load with arms in the raised position.** Always carry loads close to the ground. Do not step off platform with load raised.
4. **Check your work area, and know where all utility lines are.** Avoid hitting underground electrical wires, cables, pipes, fence posts, gas lines, uneven sidewalk edges, large rocks, etc.
5. **Never operate equipment while under the influence** of alcohol or prescription drugs, which could inhibit physical and/or mental capacity.
6. **Do not exceed rated operating capacity, as machine may become unstable, which may result in loss of control.**
7. **Slow down before turning.** Sharp turns on any terrain may cause loss of control.
8. **Always lower the loader arms to the ground,** shut off the engine, and remove the key before getting off the unit.

TRANSPORTING THE ATTACHMENT

1. **Follow all federal, state, and local regulations when transporting the unit on public roads.**
2. **Use extra care when loading or unloading the machine onto a trailer or truck.**

MAINTENANCE

1. **Never work on equipment while it is running.**
2. **Never make hydraulic repairs while the system is under pressure.** Injury or death could result.

SAFETY PRECAUTIONS

3. **Observe proper maintenance schedules** and repairs to keep the unit in safe working order.
4. **Always wear safety goggles or glasses when working on equipment.**
5. **Use a drift and hammer when pressing out pins,** to prevent the pin from shattering.
6. **Use only manufacturer recommended replacement parts.** Other parts may be substandard in fit and quality.

WARNING!



Escaping fluid under pressure can have sufficient force to penetrate the skin, causing serious personal injury. Fluid escaping from a very small hole can be almost invisible. Use a piece of cardboard or wood, rather than hands, to search for suspected leaks.

Keep unprotected body parts, such as face, eyes, and arms as far away as possible from a suspected leak. Flesh injected with hydraulic fluid may develop gangrene or other permanent disabilities.

If injured by injected fluid, see a doctor at once. If your doctor is not familiar with this type of injury, ask him to research it immediately to determine proper treatment.

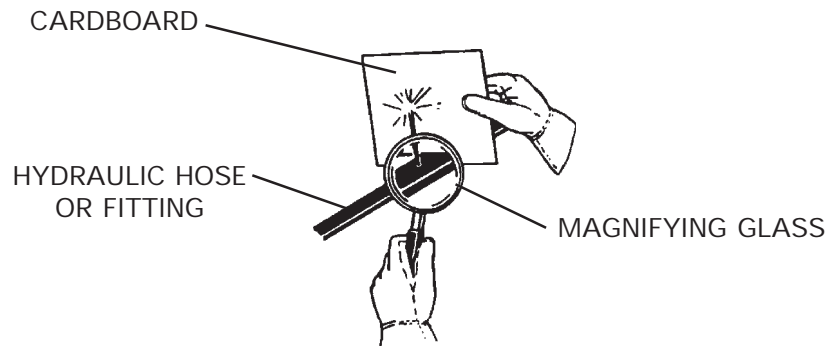

INTERNATIONAL SYMBOLS

As a guide to the operation of your equipment, various international symbols have been utilized on the instruments and controls. The symbols are shown below with an indication of their meaning.

	Engine speed		Alternator charge
	Hours recorded		Power take-off (on)
	Engine water temperature		Power take-off (off)
	Lights		"Tortoise," slow or minimum setting
	Horn		"Hare," fast or maximum setting
	Engine oil pressure		Caution
	Hazard warning		Control lever operating direction
	Axle connect		Rock shaft (raised)
	Axle disconnect		Rock shaft (lowered)
	Continuously variable		Remote cylinder (extended)
	Increase		Remote cylinder (retracted)
	Decrease		Remote cylinder (FLOAT)
	Diesel fuel		Differential lock
	Creeper range		Read operators manual
	High range		Neutral
	Low range		Forward
			Reverse

PRE-OPERATION

GENERAL INFORMATION

The purpose of this manual is to assist in setting up, operating and maintaining your **BRADCO** Tree Spade. Read it carefully. It furnishes information and instructions that will help you achieve years of dependable performance.

Unless noted otherwise, right and left are determined from the position of the operator sitting in the operator's seat facing forward.

Remember to read the "Safety Precautions" and "Operating Instructions" sections of this manual BEFORE you attempt to operate the attachment.

NOTE: The illustrations and data used in this manual were current (according to the information available to us) at the time of printing, however, we reserve the right to redesign and change the tree spade as may be necessary without notification.

BEFORE OPERATION

The primary responsibility for safety with this equipment falls to the operator. Make sure that the equipment is operated only by trained individuals that have read and understand this manual. Don't hurry the learning process or take the unit for granted. Practice the operation of your new equipment and become familiar with the controls and the way it handles on your machine.

BLADE PREPARATION

The blades are shipped with a graphite coating and should be rubbed very lightly with a fine steel wool before using. This coating prevents earth from sticking to the blades and aids in the digging operation. The words "Blade" and "Spade" are used interchangeably throughout this manual.

SKID-STEER OR OTHER HOST MACHINE

The BRADCO Tree Spades mount to various host machines such as but not limited to skid-steers, loaders, tractors and excavator's. Due to the quantity of skid-steer applications we will be referring to the host machine as a skid-steer loader throughout this manual.

The skid-steer must have front auxiliary hydraulics and a 12 Volt DC electrical power source available for spade operation. The **BRADCO** Model 2415 requires a minimum of 1500 lbs. lifting capacity and the Model 3215 requires a minimum of 2400 lbs. lifting capacity. The **BRADCO** Tree Spades are NOT designed for use on high flow skid-steers.

Rear stabilizers are recommended to get the maximum performance of your tree spade. The rear stabilizers allow as much weight as possible to be transferred to the front of the skid-steer and therefore to the tree spade for maximum digging ability.

PRE-OPERATION

MAJOR NOMENCLATURE

Throughout this manual, reference is made to various attachment components. The purpose of this section is to acquaint you with the various names of these components. This knowledge will be helpful when reading through the manual or when ordering service parts.

The blades are identified in a clockwise direction starting with the left rear spade.

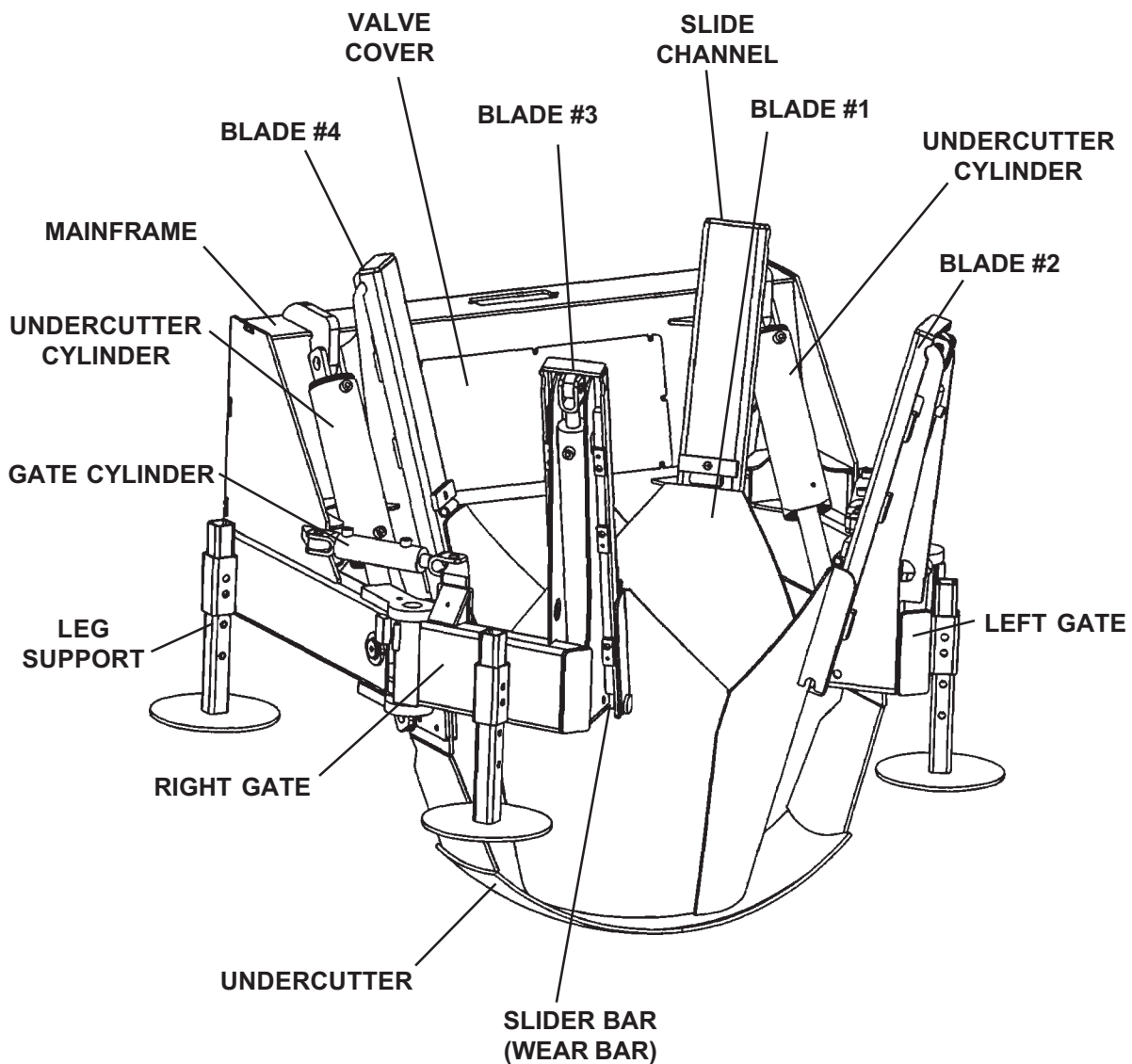
Model 3215 Tree Spade shown

2415 TREE SPADE

MAINFRAME ASSEMBLY #25245

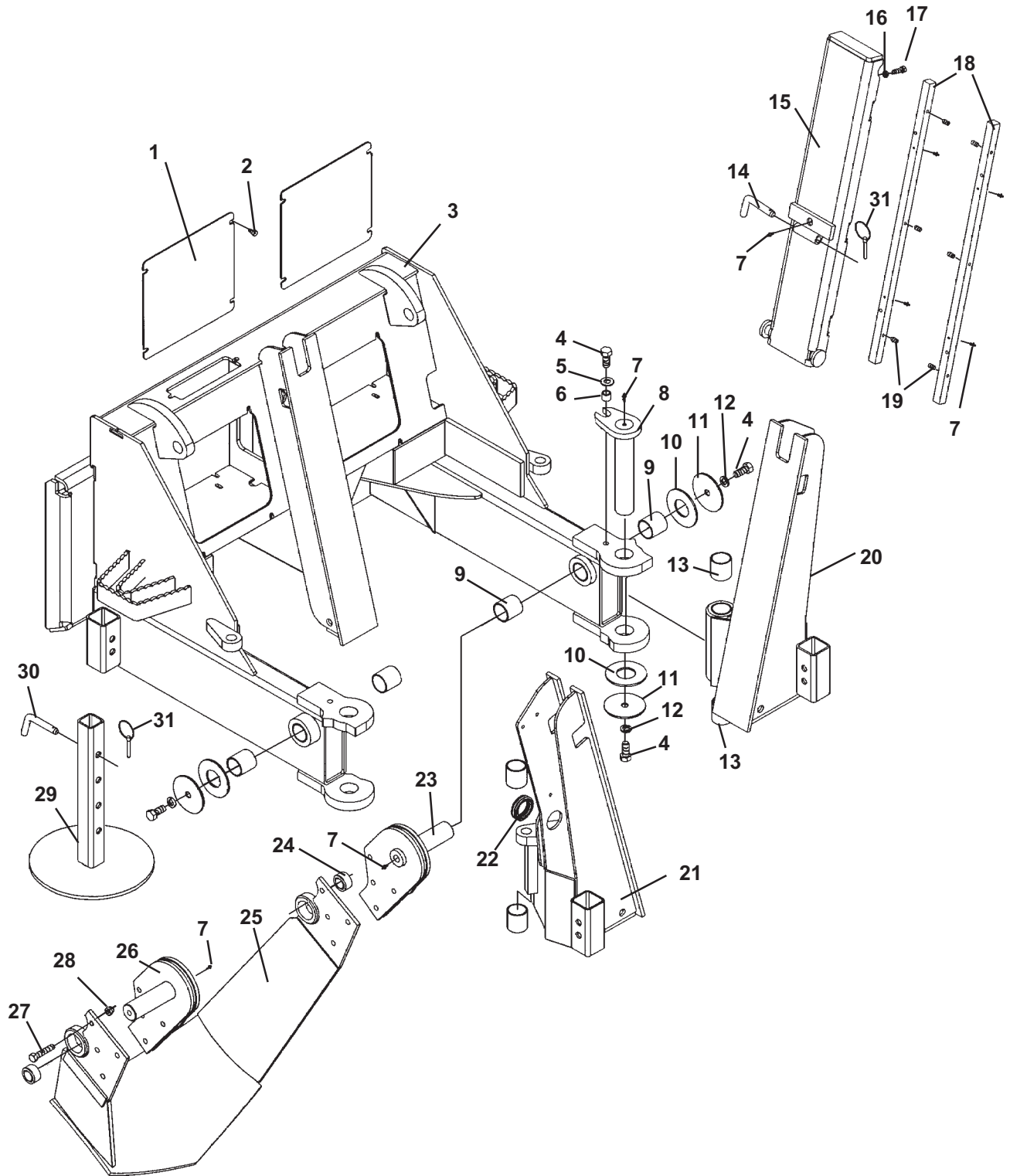

2415 TREE SPADE

MAINFRAME ASSEMBLY #25245

<u>NO</u>	<u>REQ'D</u>	<u>PART NO.</u>	<u>DESCRIPTION</u>
1	2	25282	Valve Cover
2	10	1953	.38" UNC X .75" Hex Screw
3	1	25293	Mainframe with Universal Hitch
	-	88987	Replacement Universal Hitch Plate (Weld-On)
4	6	1114	.62" UNC X 1.50" Hex Capscrew
5	2	1627	.62" Hard Flat Washer
6	2	25075	Spacer Tube
7	19	6616	Grease Fitting
8	2	25065	Pivot Pin
9	-	6356	Replacement Bushing (Included with Mainframe)
10	As Req'd	6622	Thrust Washer
11	4	25132	Special Washer (.69" x 2.50" x .38")
12	4	1506	.62" Lock Washer
13	-	6356	Replacement Bushing (Included with Left and Right Arm Weldments)
14	3	25118	Hitch Pin
15	3	25291	Slide Channel
16	18	1226	.38" UNC Hex Nut
17	18	1043	.38" UNC X 1.00" Hex Capscrew
18	6	25281	Slider Bar
19	18	1573	.38" UNC X .75" Set Screw
20	1	25256	Left Arm
21	1	25255	Right Arm
22	2	89088	Grommet
23	1	25275	Left Pivot
24	2	62523	Bushing
25	1	25270	Undercutter Blade
26	1	25276	Right Pivot
27	8	1965	.50" UNC X 2.50" Hex Capscrew - Grade 8
28	8	1841	.50" UNC Deformed Lock Nut
29	4	25144	Leg
30	4	89951	Hitch Pin
31	7	21169	Klik Pin

2415 TREE SPADE

MAINFRAME ASSEMBLY #25245

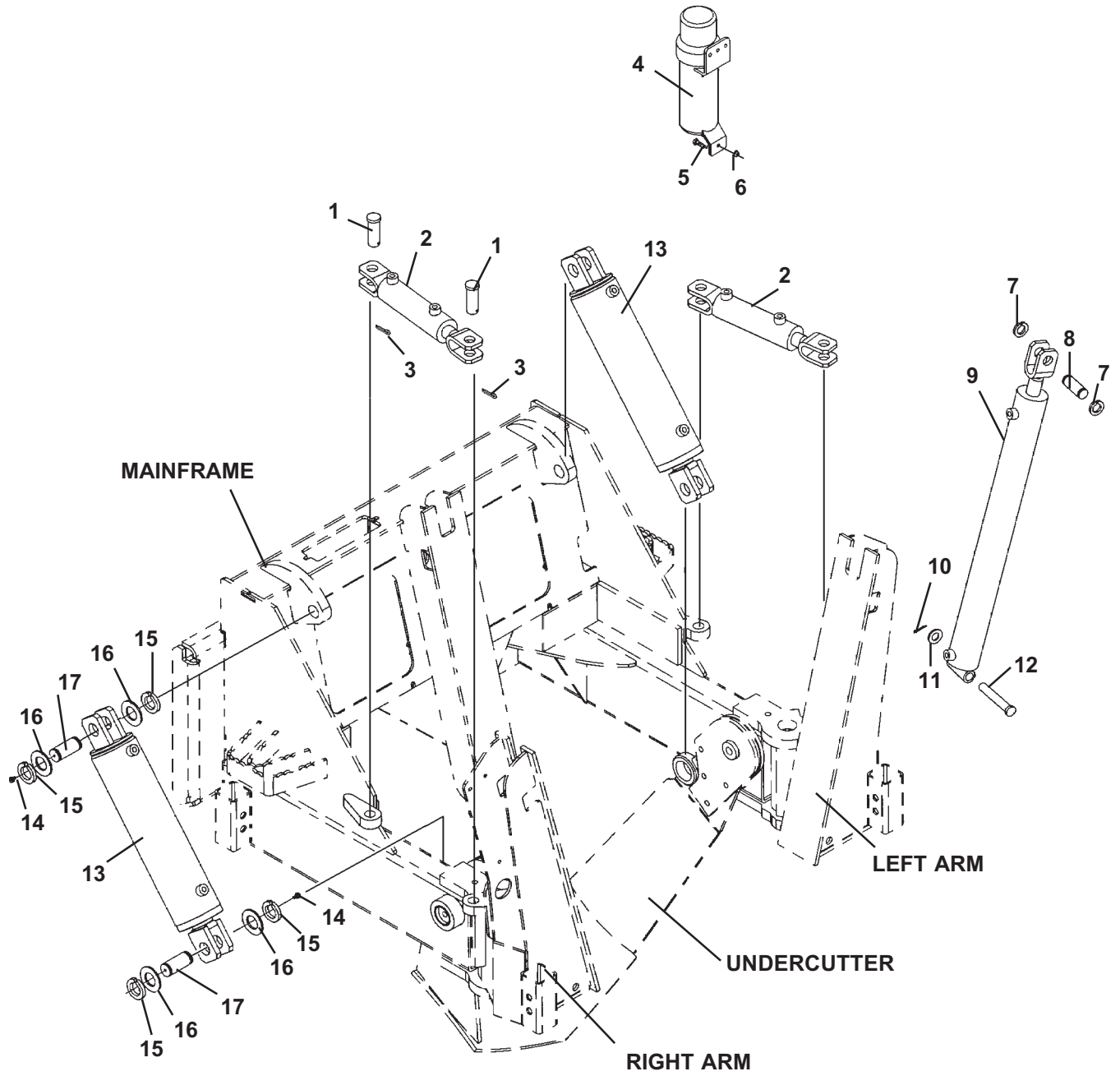

2415 TREE SPADE

MAINFRAME ASSEMBLY #25245

<u>NO</u>	<u>REQ'D</u>	<u>PART NO.</u>	<u>DESCRIPTION</u>
1	4	5097	Cylinder Pivot Pin
2	2	25005	Cylinder Assembly - Gate
3	4	1793	Cotter Pin
4	1	25453	Manual Storage Tube
5	3	1022	.31" UNC X 1.00" Hex Capscrew
6	3	1753	.31" UNC NyLock Nut
7	6	6612	Snap Ring
8	3	63302	Cylinder Pivot Pin
9	3	25247	Cylinder Assembly - Blades
10	3	1611	Cotter Pin
11	3	1649	.75" Hard Flat Washer
12	3	22260	Cylinder Pivot Pin
13	2	25240	Cylinder Assembly - Undercutter
14	4	6616	Grease Fitting
15	8	1652	Snap Ring
16	8	57693	Thrust Washer
17	4	25067	Cylinder Pivot Pin

MOUNTING KIT INSTALLATION

2415 HYDRAULIC ASSEMBLY #25430
POWER AND RETURN CIRCUIT

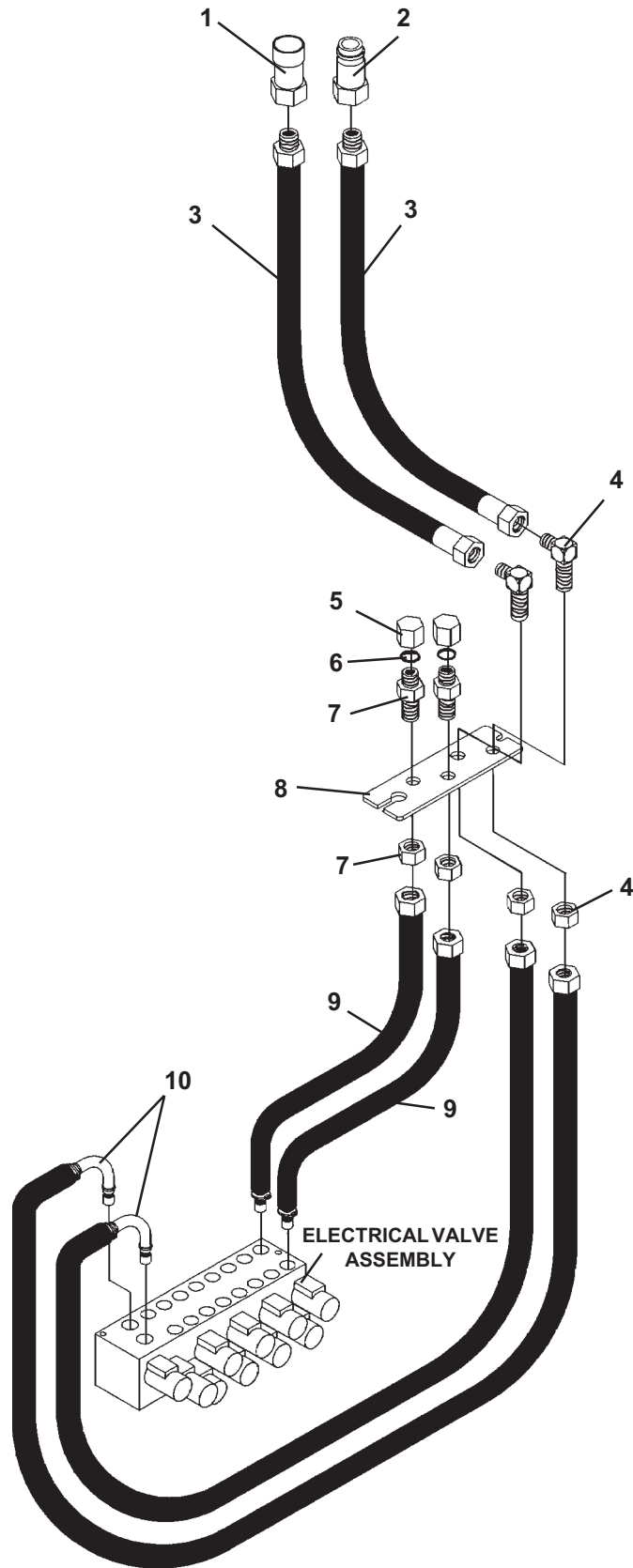

MOUNTING KIT INSTALLATION

2415 HYDRAULIC ASSEMBLY #25430
POWER AND RETURN CIRCUIT

<u>NO</u>	<u>REQ'D</u>	<u>PART NO.</u>	<u>DESCRIPTION</u>
1	1	14175	Female Coupler
2	1	14176	Male Coupler
3	2	35847	Hose .50" X 60" 8MBo-8FJX
4	2	3382	90° Bulkhead Elbow 8MJ-8MJ (Includes Nut)
5	2	3105	Cap
6	2	3306	O-Ring
7	2	3275	Straight Bulkhead Connector 8MJ-8MJ (Includes Nut)
8	1	25448	Bulkhead Mounting Plate
9	2	38210	Hose .38" X 32" 8FJX -.38 WEO
10	2	38209	Hose .50" X 21" 8FJX -.50 WEO 90°

MOUNTING KIT INSTALLATION

2415 HYDRAULIC ASSEMBLY #25430
BLADE CIRCUIT

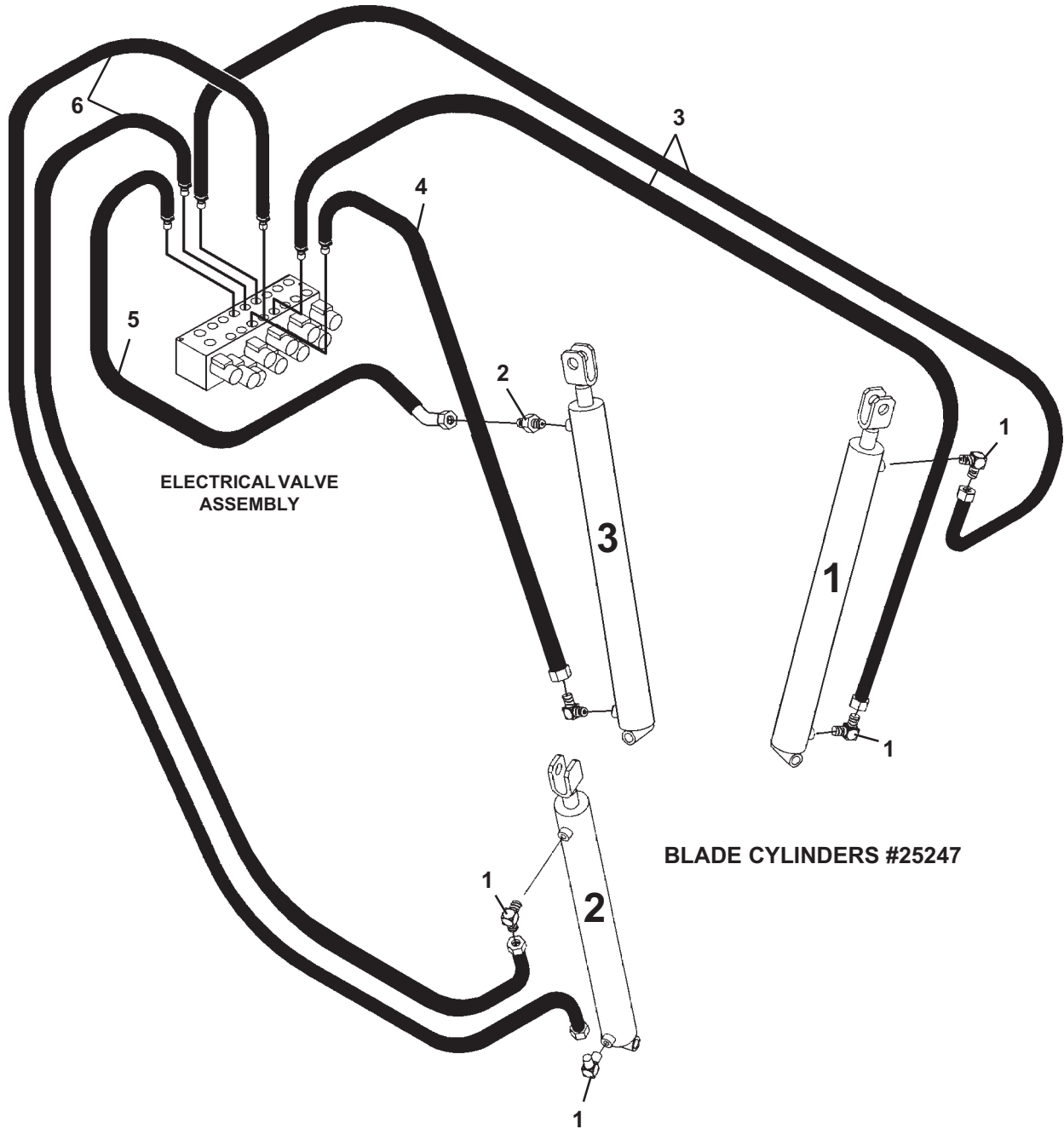

MOUNTING KIT INSTALLATION

2415 HYDRAULIC ASSEMBLY #25430
BLADE CIRCUIT

<u>NO</u>	<u>REQ'D</u>	<u>PART NO.</u>	<u>DESCRIPTION</u>
1	5	3434	90° Elbow 6MBo-6MJ
2	1	3457	Straight Adapter 6MBo-6MJ
3	2	38211	Hose .25" X 62" 6FJX -. 38 WEO
4	1	38213	Hose .25" X 36" 6FJX -. 38 WEO
5	1	38214	Hose .25" X 19" 6FJX -. 38 WEO
6	2	38212	Hose .25" X 85" 6FJX -. 38 WEO

MOUNTING KIT INSTALLATION

2415 HYDRAULIC ASSEMBLY #25430
GATE CIRCUIT

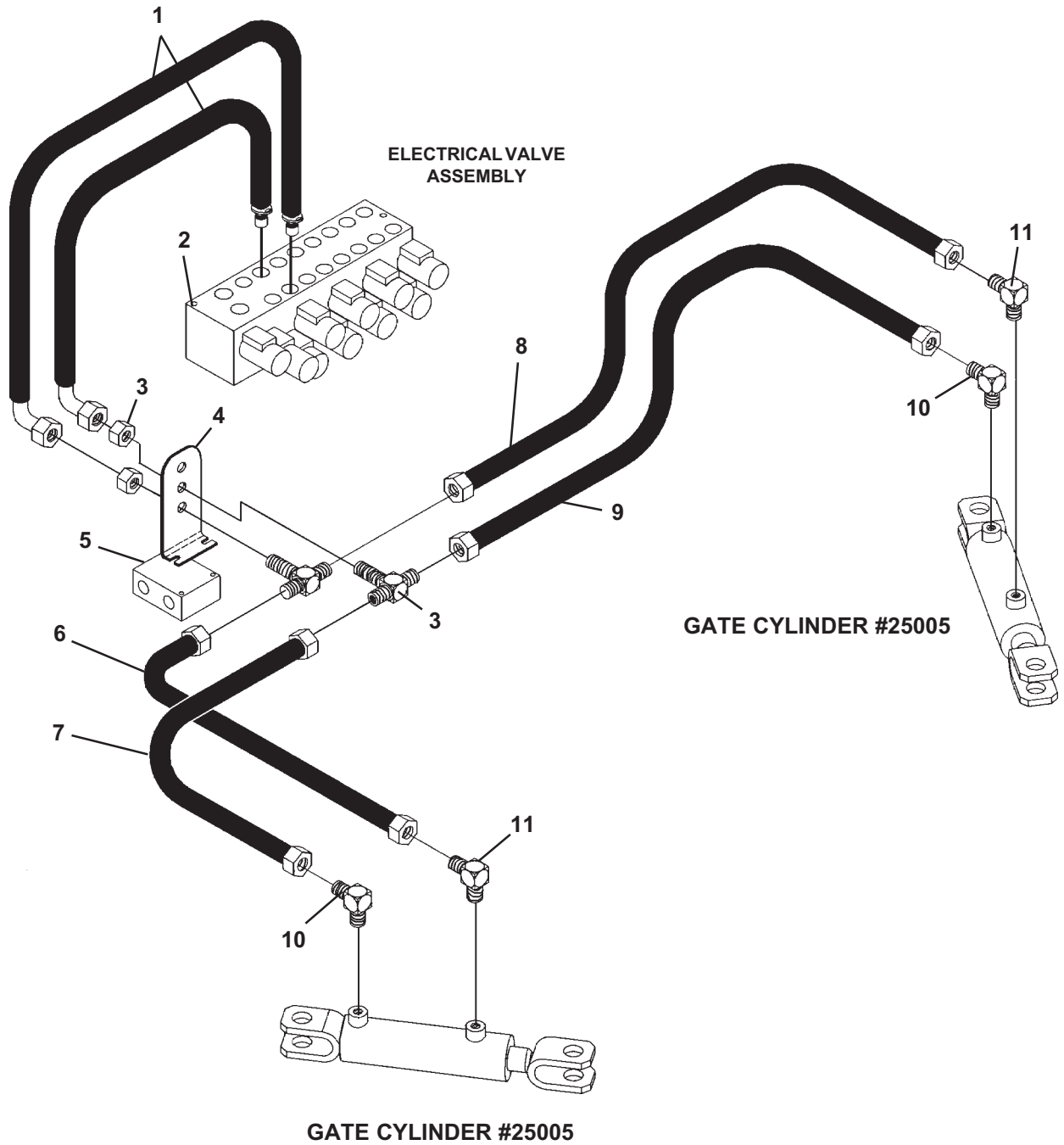

MOUNTING KIT INSTALLATION

2415 HYDRAULIC ASSEMBLY #25430
GATE CIRCUIT

<u>NO</u>	<u>REQ'D</u>	<u>PART NO.</u>	<u>DESCRIPTION</u>
1	2	38216	Hose .25" X 28" 6FJX 90° - .38 WEO
2	2	1035	.31" UNC X 4.50" Hex Capscrew
	2	1513	.31" Flat Washer
	2	1753	.31" UNC Nylock Nut
3	2	3498	Bulkhead Tee 6MJ-6MJ-6MJ
4	1	25454	Bulkhead Mounting Plate
	2	1007	.25" UNC X 2.00" Hex Capscrew
	2	1512	.25" Flat Washer
	2	1629	.25" UNC Nylock Nut
5	1	25153	Flow Divider
6	1	35694	Hose .25" X 34" 6FJX - 6FJX
7	1	38217	Hose .25" X 27" 6FJX - 6FJX
8	1	37440	Hose .25" X 55" 6FJX - 6FJX
9	1	35807	Hose .25" X 50" 6FJX - 6FJX
10	2	3434	90° Elbow 6MBo-6MJ
11	2	30259	90° Elbow 6MBo-6MJ with .060 Orifice

MOUNTING KIT INSTALLATION

2415 HYDRAULIC ASSEMBLY #25430
UNDERCUTTER CIRCUIT

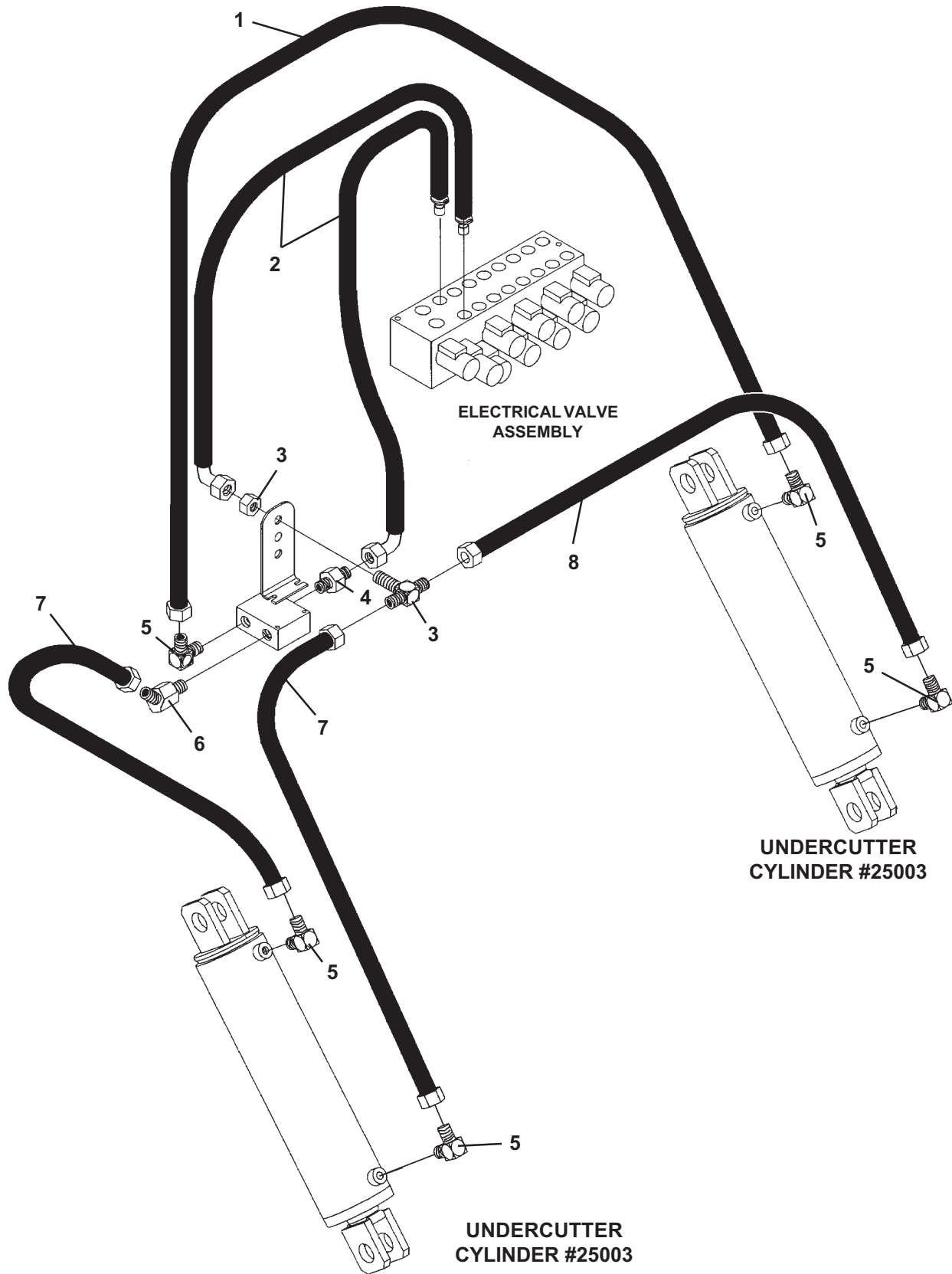

MOUNTING KIT INSTALLATION

2415 HYDRAULIC ASSEMBLY #25430
UNDERCUTTER CIRCUIT

<u>NO</u>	<u>REQ'D</u>	<u>PART NO.</u>	<u>DESCRIPTION</u>
1	1	37575	Hose .25" X 53" 6FJX - 6FJX
2	2	38215	Hose .38" X 26" 6FJX 90° - .38 WEO
3	1	3498	Bulkhead Tee 6MJ-6MJ-6MJ
4	1	3269	Straight Connector 8MBo-6MJ
5	5	3434	90° Elbow 6MBo-6MJ
6	1	30313	45° Elbow 6MBo-6MJ
7	2	38184	Hose .25" X 30" 6FJX - 6FJX
8	1	35807	Hose .25" X 50" 6FJX - 6FJX

3215 TREE SPADE

MAINFRAME ASSEMBLY #25151

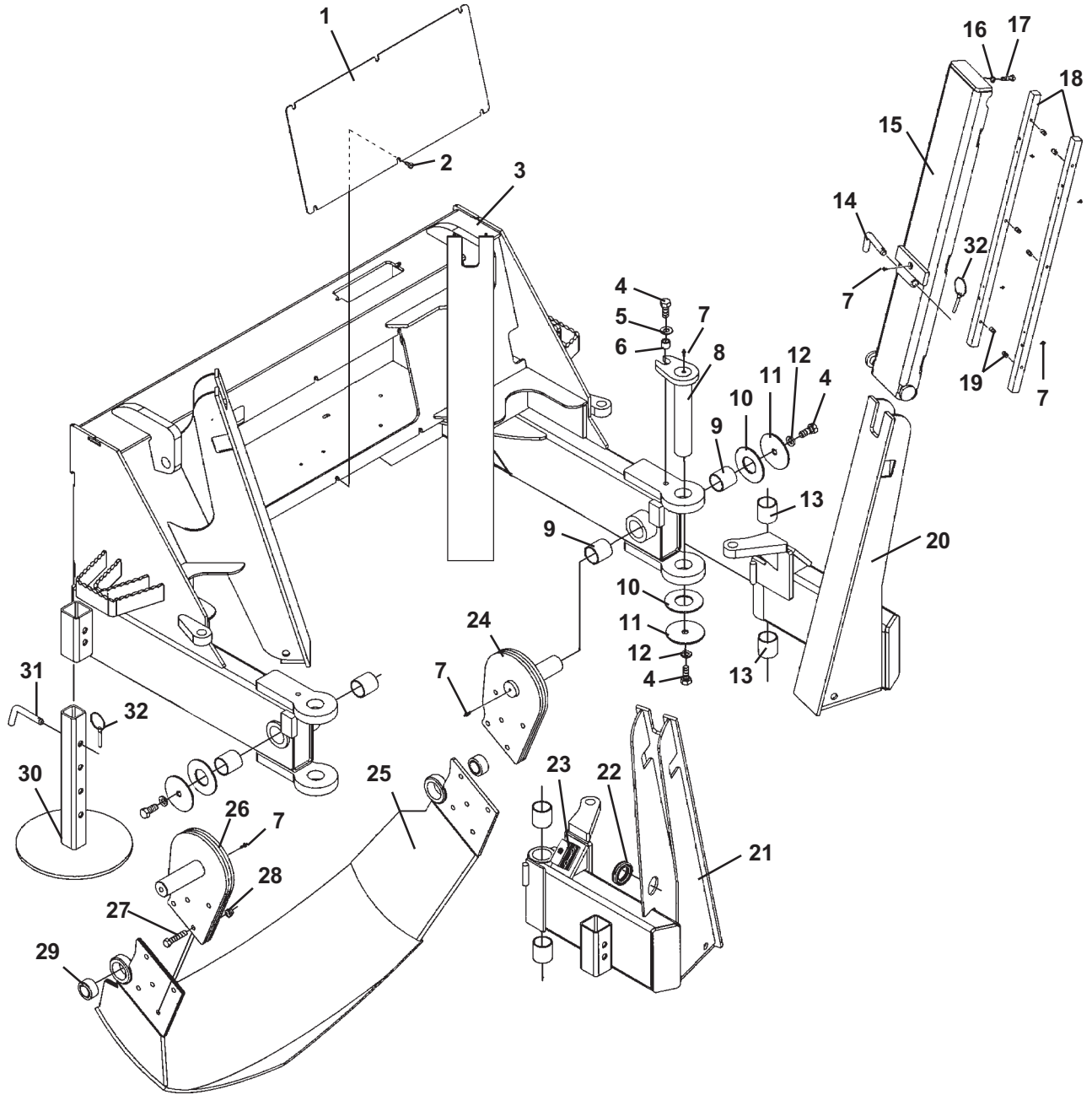

3215 TREE SPADE

MAINFRAME ASSEMBLY #25151

<u>NO</u>	<u>REQ'D</u>	<u>PART NO.</u>	<u>DESCRIPTION</u>
1	1	25131	Valve Cover
2	8	1953	.38" UNC X .75" Hex Screw
3	1	25246	Mainframe with Universal Hitch
	-	88987	Replacement Universal Hitch Plate (Weld-On)
4	6	1114	.62" UNC X 1.50" Hex Capscrew
5	2	1627	.62" Hard Flat Washer
6	2	25075	Spacer Tube
7	24	6616	Grease Fitting
8	2	25065	Pivot Pin
9	-	6356	Replacement Bushing (Included with Mainframe)
10	As Req'd	6622	Thrust Washer
11	4	25132	Special Washer (.69" x 2.50" x .38")
12	4	1506	.62" Lock Washer
13	-	6356	Replacement Bushing (Included with Left and Right Arm Weldments)
14	4	25118	Hitch Pin
15	4	25051	Slide Channel
16	24	1226	.38" UNC Hex Nut
17	24	1043	.38" UNC X 1.00" Hex Capscrew
18	8	25233	Slider Bar
19	24	1573	.38" UNC X .75" Set Screw
20	1	25076	Left Arm
21	1	25077	Right Arm
22	2	89088	Grommet
23	-	81358	Replacement Hose Clamp (Included with Left and Right Arm Weldments)
24	1	25133	Left Pivot
25	1	25139	Undercutter Blade
26	1	25134	Right Pivot
27	10	1965	.50" UNC X 2.50" Hex Capscrew - Grade 8
28	10	1841	.50" UNC Deformed Lock Nut
29	2	62523	Bushing
30	4	25144	Leg
31	4	89951	Hitch Pin
32	8	21169	Klik Pin

3215 TREE SPADE

MAINFRAME ASSEMBLY #25151

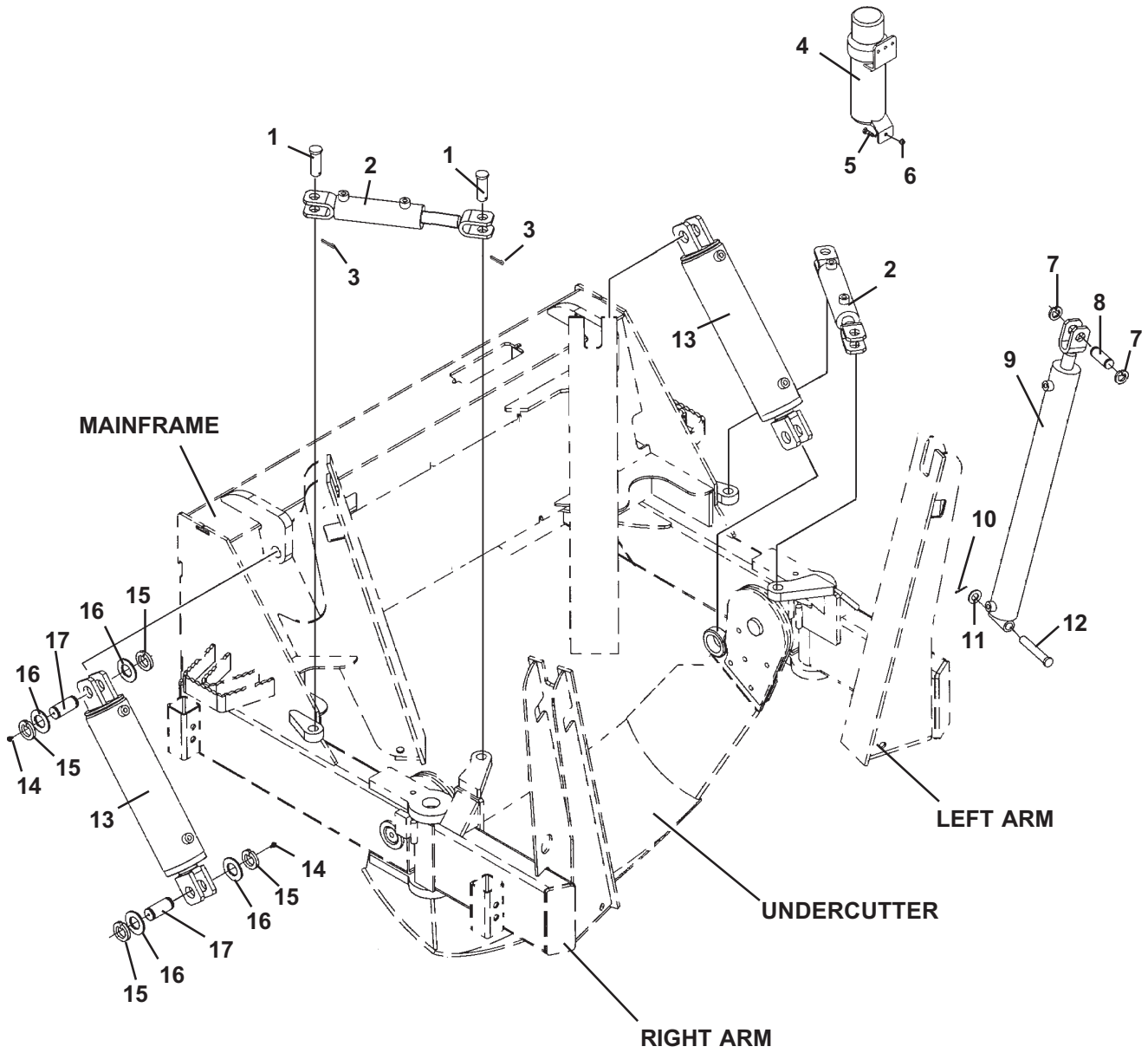

3215 TREE SPADE

MAINFRAME ASSEMBLY #25151

<u>NO</u>	<u>REQ'D</u>	<u>PART NO.</u>	<u>DESCRIPTION</u>
1	4	5097	Cylinder Pivot Pin
2	2	25005	Cylinder Assembly - Gate
3	4	1793	Cotter Pin
4	1	25453	Manual Storage Tube
5	3	1022	.31" UNC X 1.00" Hex Capscrew
6	3	1753	.31" UNC NyLock Nut
7	8	6612	Snap Ring
8	4	63302	Cylinder Pivot Pin
9	4	25004	Cylinder Assembly - Blades
10	4	1611	Cotter Pin
11	4	1649	.75" Hard Flat Washer
12	4	22260	Cylinder Pivot Pin
13	2	25003	Cylinder Assembly - Undercutter
14	4	6616	Grease Fitting
15	8	1652	Snap Ring
16	8	57693	Thrust Washer
17	4	25067	Cylinder Pivot Pin

MOUNTING KIT INSTALLATION

3215 HYDRAULIC ASSEMBLY #25424
POWER AND RETURN CIRCUIT

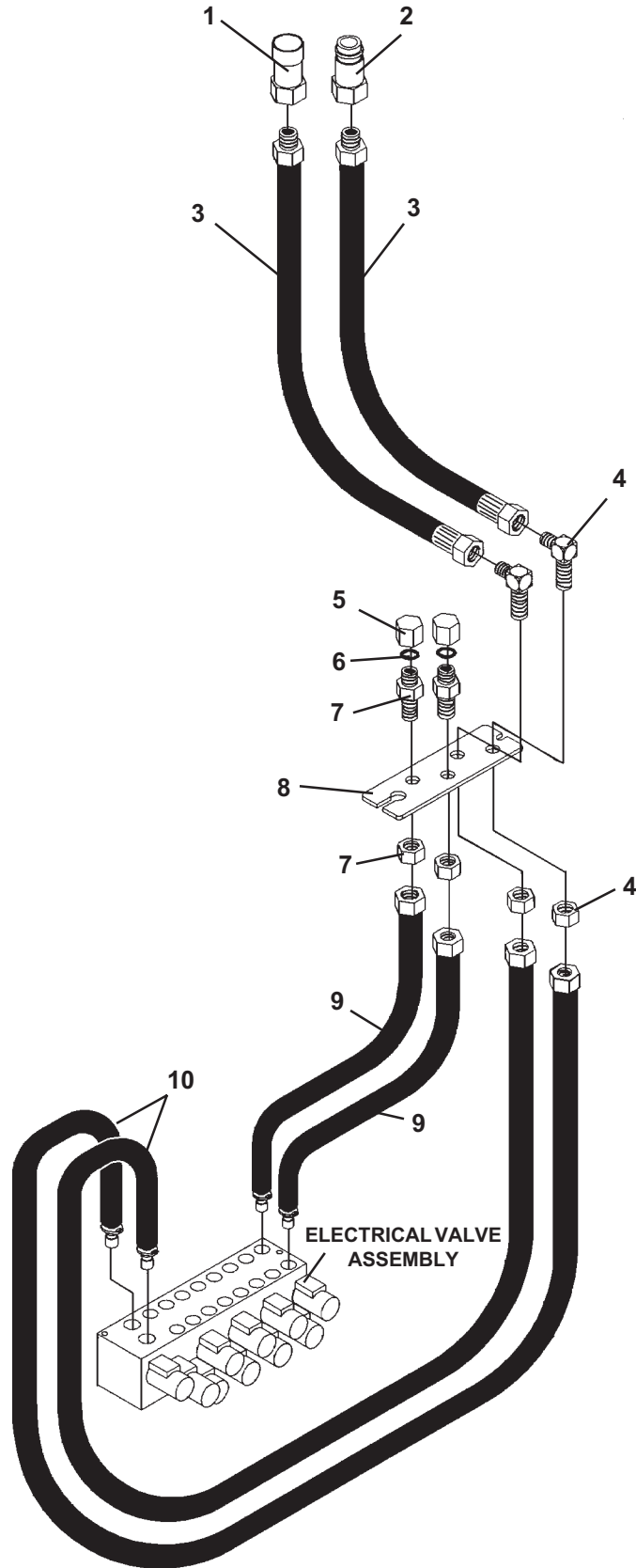

MOUNTING KIT INSTALLATION

3215 HYDRAULIC ASSEMBLY #25424
POWER AND RETURN CIRCUIT

<u>NO</u>	<u>REQ'D</u>	<u>PART NO.</u>	<u>DESCRIPTION</u>
1	1	14175	Female Coupler
2	1	14176	Male Coupler
3	2	35847	Hose .50" X 60" 8MBo-8FJX
4	2	3382	90° Bulkhead Elbow 8MJ-8MJ (Includes Nut)
5	2	3105	Cap
6	2	3306	O-Ring
7	2	3275	Straight Bulkhead Connector 8MJ-8MJ (Includes Nut)
8	1	25448	Bulkhead Mounting Plate
9	2	38180	Hose .38" X 30" 8FJX -. 38 WEO
10	2	38181	Hose .50" X 34" 8FJX -. 50 WEO

MOUNTING KIT INSTALLATION

3215 HYDRAULIC ASSEMBLY #25424
BLADE CIRCUIT

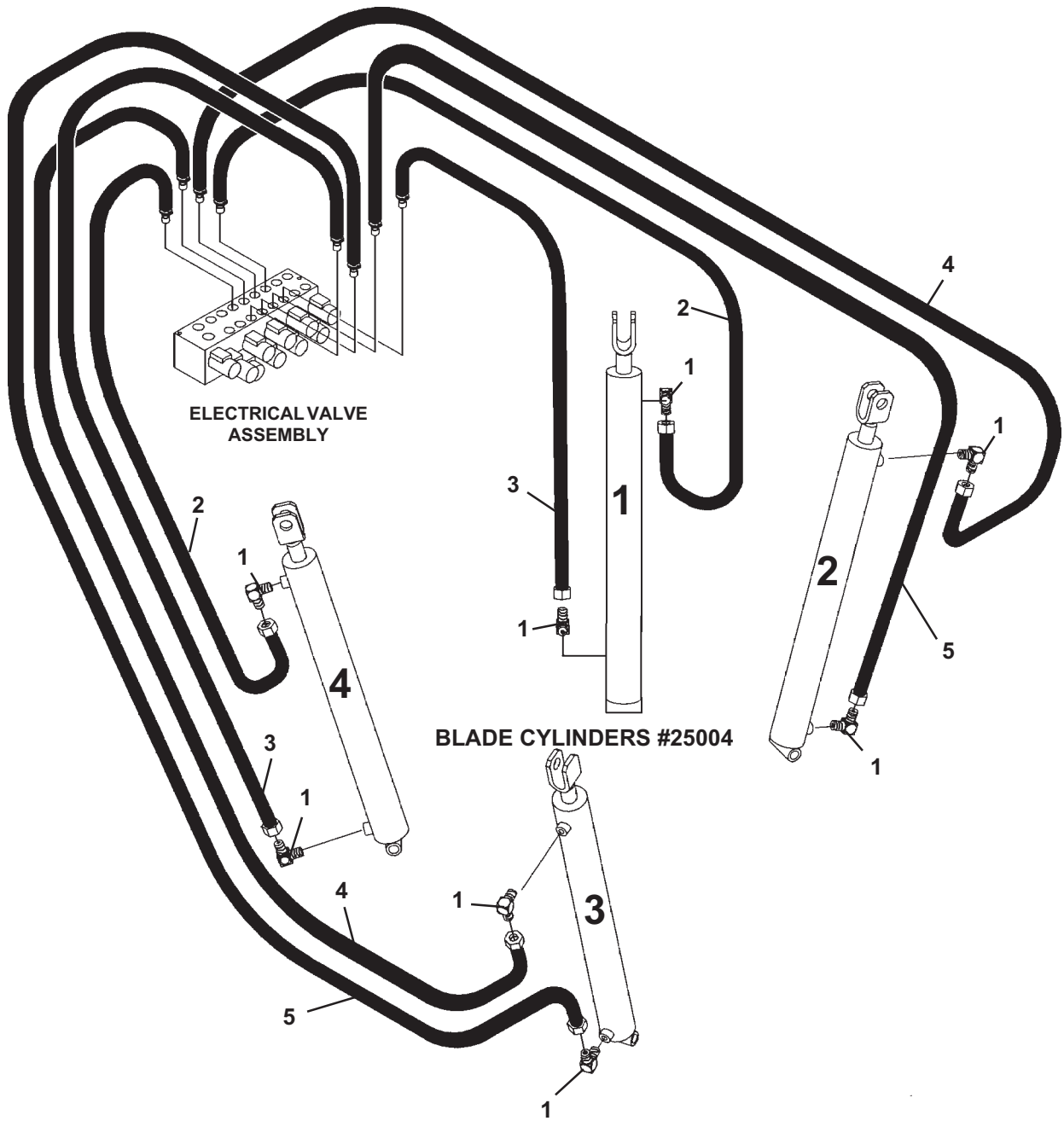

MOUNTING KIT INSTALLATION

3215 HYDRAULIC ASSEMBLY #25424
BLADE CIRCUIT

<u>NO</u>	<u>REQ'D</u>	<u>PART NO.</u>	<u>DESCRIPTION</u>
1	8	3434	90° Elbow 6MBo-6MJ
2	2	38183	Hose .38" X 62" 6FJX -.38 WEO
3	2	38222	Hose .38" X 84" 6FJX -.38 WEO
4	2	38178	Hose .38" X 96" 6FJX -.38 WEO
5	2	38179	Hose .38" X 88" 6FJX -.38 WEO

MOUNTING KIT INSTALLATION

3215 HYDRAULIC ASSEMBLY #25424
GATE CIRCUIT

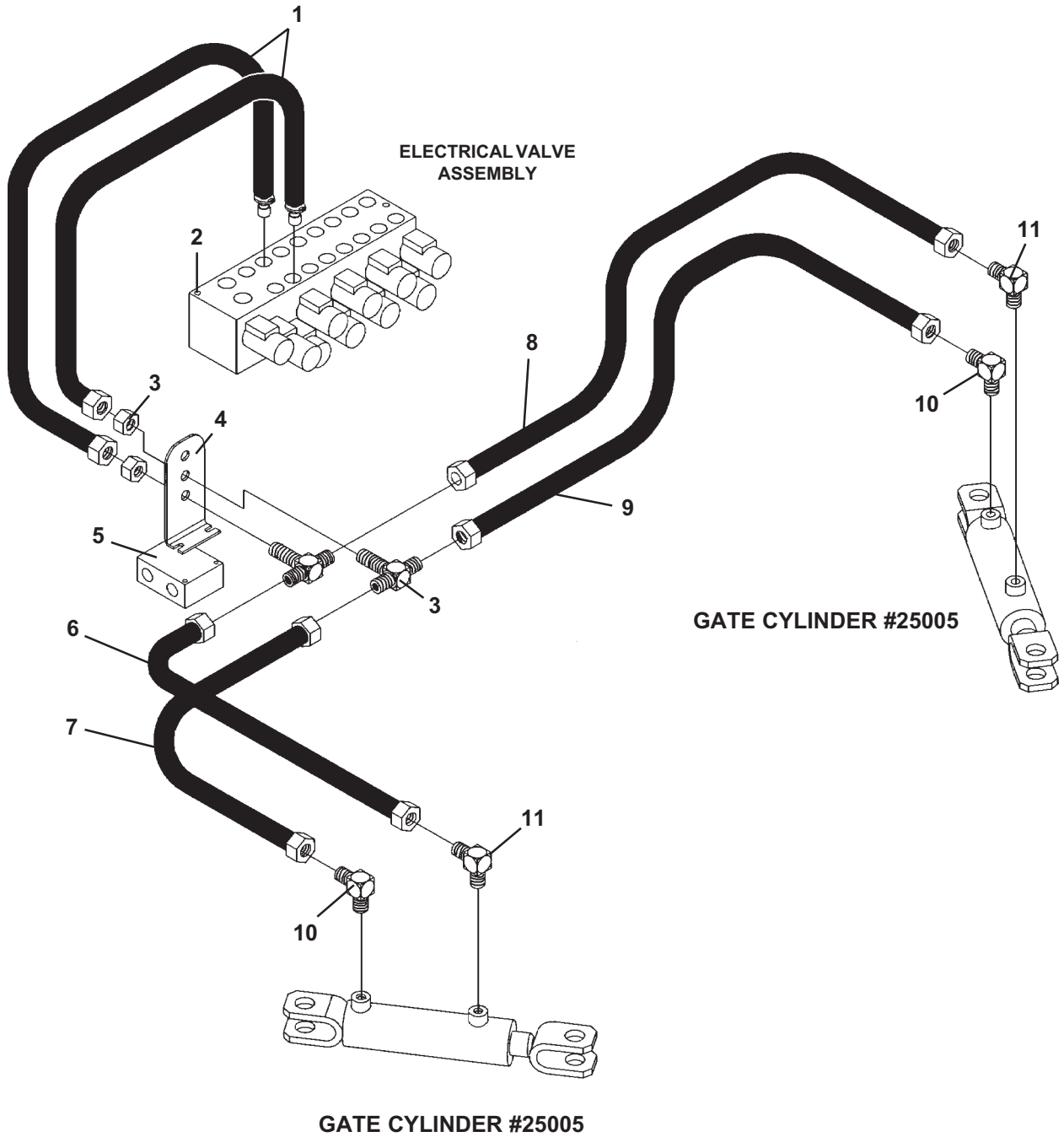

MOUNTING KIT INSTALLATION

3215 HYDRAULIC ASSEMBLY #25424
GATE CIRCUIT

<u>NO</u>	<u>REQ'D</u>	<u>PART NO.</u>	<u>DESCRIPTION</u>
1	2	38177	Hose .25" X 22" 6FJX - .38 WEO
2	2	1035	.31" UNC X 4.50" Hex Capscrew
	2	1513	.31" Flat Washer
	2	1753	.31" UNC Nylock Nut
3	2	3498	Bulkhead Tee 6MJ-6MJ-6MJ
4	1	25454	Bulkhead Mounting Plate
	2	1007	.25" UNC X 2.00" Hex Capscrew
	2	1512	.25" Flat Washer
	2	1629	.25" UNC Nylock Nut
5	1	25153	Flow Divider
6	1	37916	Hose .25" X 40" 6FJX - 6FJX
7	1	35694	Hose .25" X 34" 6FJX - 6FJX
8	1	35829	Hose .25" X 60" 6FJX - 6FJX
9	1	37440	Hose .25" X 55" 6FJX - 6FJX
10	2	3434	90° Elbow 6MBo-6MJ
11	2	30259	90° Elbow 6MBo-6MJ with .060 Orifice

MOUNTING KIT INSTALLATION

3215 HYDRAULIC ASSEMBLY #25424
UNDERCUTTER CIRCUIT

<u>NO</u>	<u>REQ'D</u>	<u>PART NO.</u>	<u>DESCRIPTION</u>
1	1	35829	Hose .25" X 60" 6FJX - 6FJX
2	2	38176	Hose .38" X 20" 6FJX - 90° .38 WEO
3	1	3498	Bulkhead Tee 6MJ-6MJ-6MJ
4	1	3269	Straight Connector 8MBo-6MJ
5	5	3434	90° Elbow 6MBo-6MJ
6	1	30313	45° Elbow 6MBo-6MJ
7	2	35694	Hose .25" X 34" 6FJX - 6FJX
8	1	37440	Hose .25" X 55" 6FJX - 6FJX

MOUNTING KIT INSTALLATION

CYLINDER ASSEMBLY #25003

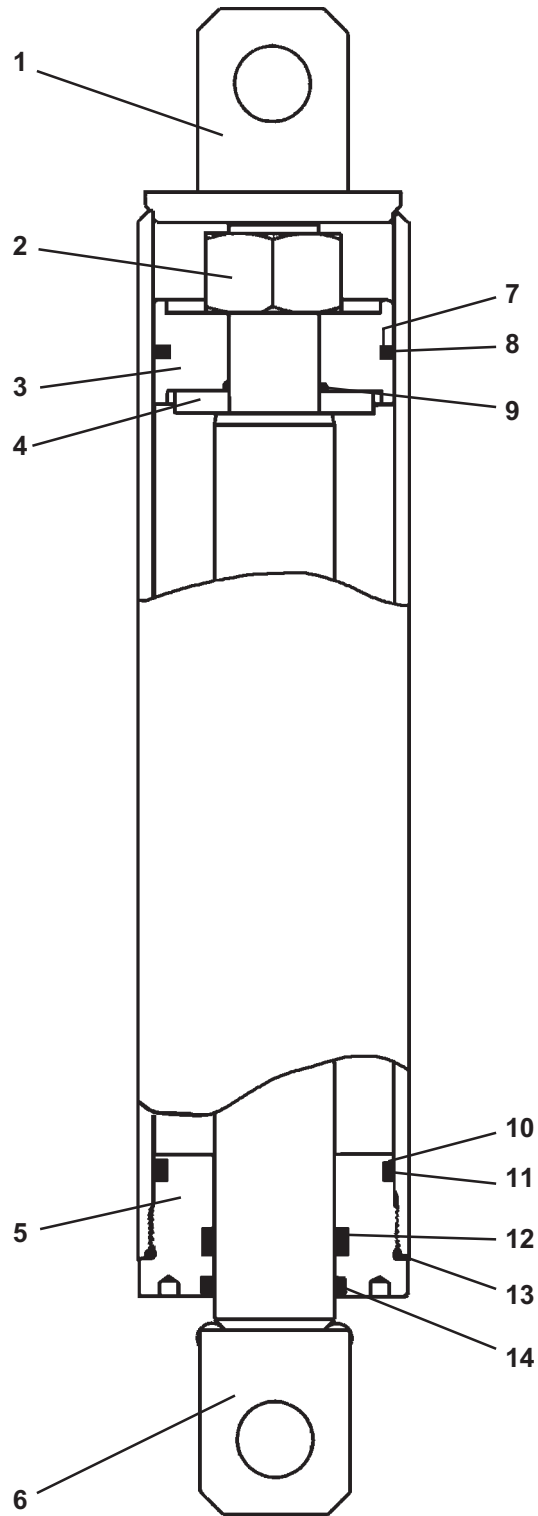

MOUNTING KIT INSTALLATION

CYLINDER ASSEMBLY #25003

<u>NO</u>	<u>REQ'D</u>	<u>PART NO.</u>	<u>DESCRIPTION</u>
1	1	25020	Cylinder Tube
2	1	1487	Hex Nut
3	1	73834	Piston
4	1	54958	Washer
5	1	77455	Cylinder Gland
6	1	25018	Cylinder Rod
7	1	45509*	O'Ring
8	1	4816*	Piston Ring
9	1	45109*	O'Ring
10	1	45516*	O'Ring
11	1	45515*	Back-Up Washer
12	1	45117*	PolyPak Seal
13	1	45519*	O'Ring
14	1	45364*	Rod Wiper

NOTE: Seal Kit #45813 includes all parts marked with an asterisk (*). parts are not sold separately.

MOUNTING KIT INSTALLATION

CYLINDER ASSEMBLY #25004

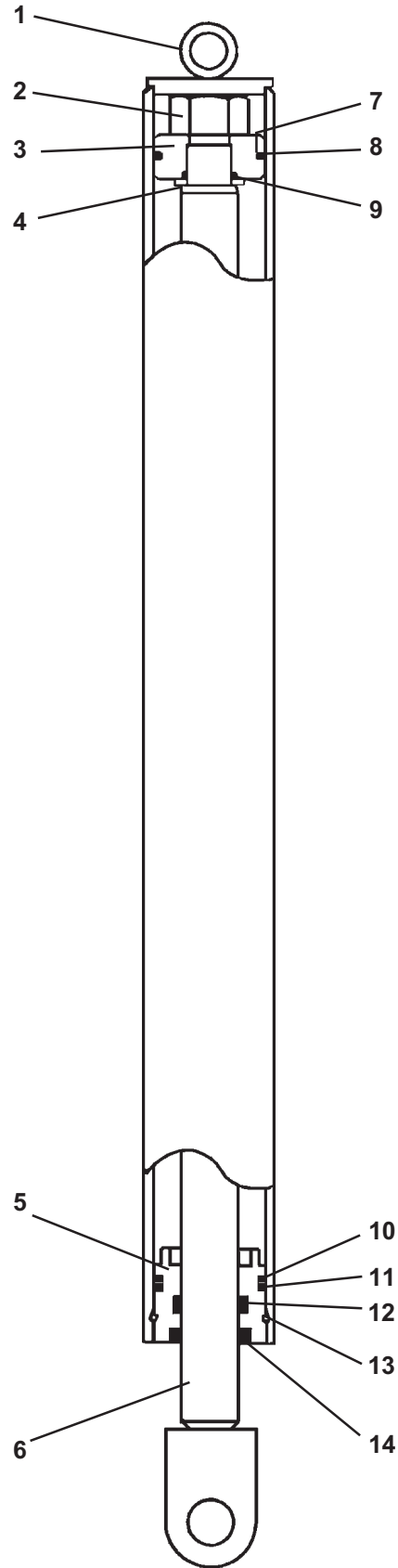

MOUNTING KIT INSTALLATION

CYLINDER ASSEMBLY #25004

<u>NO</u>	<u>REQ'D</u>	<u>PART NO.</u>	<u>DESCRIPTION</u>
1	1	25014	Cylinder Tube
2	1	1483	Hex Nut
3	1	50252	Piston
4	1	5421	Washer
5	1	62770	Cylinder Gland
6	1	25012	Cylinder Rod
7	1	4645*	O'Ring
8	1	4644*	Piston Ring
9	1	4641*	O'Ring
10	1	4509*	O'Ring
11	1	4510*	Back-Up Washer
12	1	45219*	PolyPak Seal
13	1	7165*	Cylinder Gland Retaining Ring
14	1	4974*	Rod Wiper

NOTE: Seal Kit #45258 includes all parts marked with an asterisk (*). parts are not sold separately.

MOUNTING KIT INSTALLATION

CYLINDER ASSEMBLY #25005

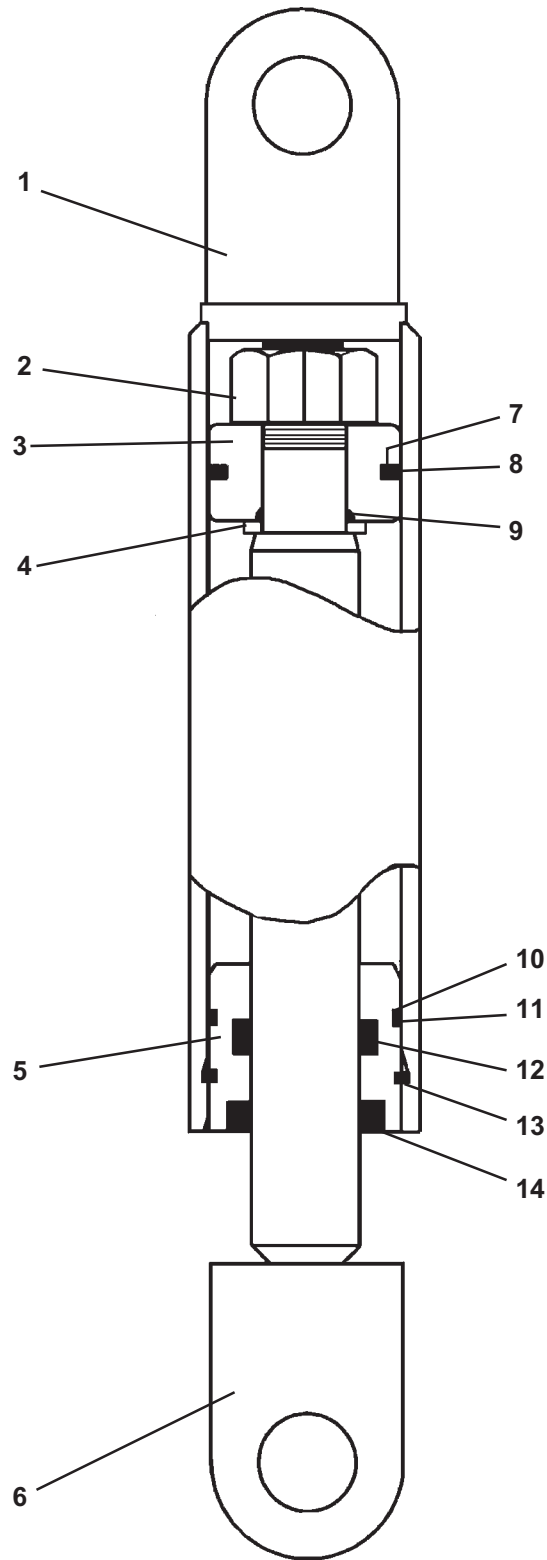

MOUNTING KIT INSTALLATION

CYLINDER ASSEMBLY #25005

<u>NO</u>	<u>REQ'D</u>	<u>PART NO.</u>	<u>DESCRIPTION</u>
1	1	25010	Cylinder Tube
2	1	1482	Hex Nut
3	1	6992	Piston
4	1	52644	Washer
5	1	64891	Cylinder Gland
6	1	25008	Cylinder Rod
7	1	4637*	O'Ring
8	1	4636*	Piston Ring
9	1	4635*	O'Ring
10	1	4633*	O'Ring
11	1	4634*	Back-Up Washer
12	1	45262*	PolyPak Seal
13	1	7164*	Cylinder Gland Retaining Ring
14	1	4981*	Rod Wiper

NOTE: Seal Kit #45581 includes all parts marked with an asterisk (*). parts are not sold separately.

MOUNTING KIT INSTALLATION

CYLINDER ASSEMBLY #25240

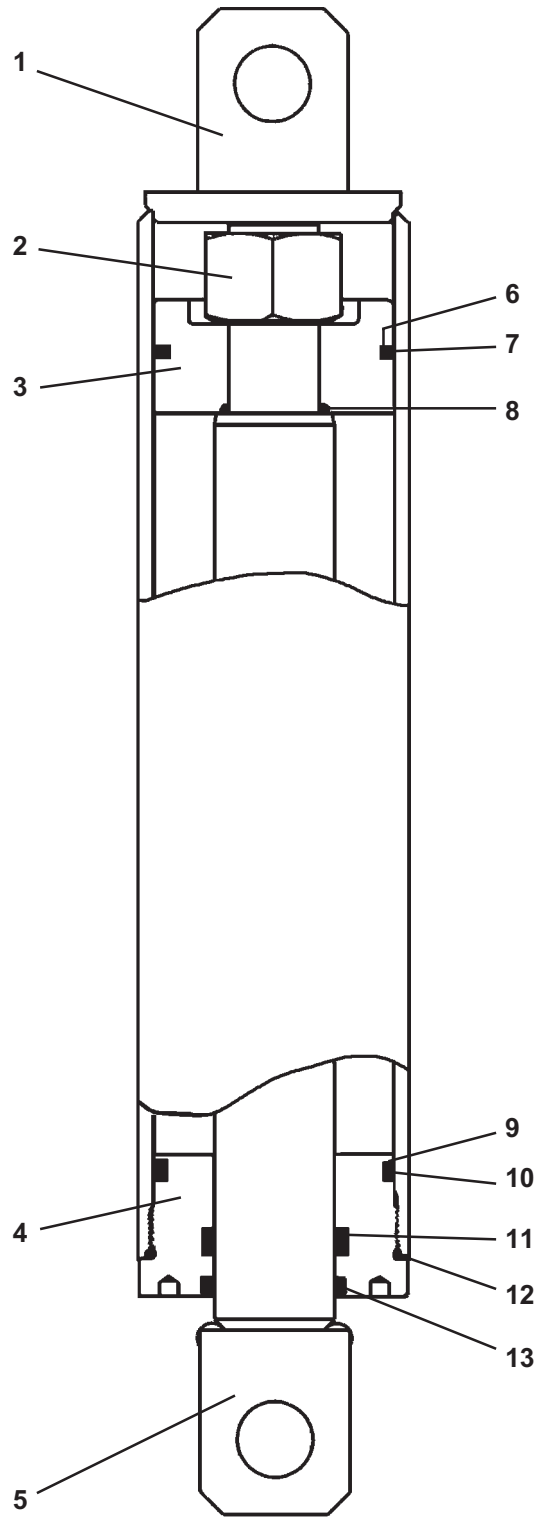

MOUNTING KIT INSTALLATION

CYLINDER ASSEMBLY #25240

<u>NO</u>	<u>REQ'D</u>	<u>PART NO.</u>	<u>DESCRIPTION</u>
1	1	25241	Cylinder Tube
2	1	1483	Hex Nut
3	1	18440	Piston
4	1	77451	Cylinder Gland
5	1	25242	Cylinder Rod
6	1	45245*	O'Ring
7	1	45244*	Piston Ring
8	1	4641*	O'Ring
9	1	45242*	O'Ring
10	1	45243*	Back-Up Washer
11	1	45119*	PolyPak Seal
12	1	45412*	O'Ring
13	1	45370*	Rod Wiper

NOTE: Seal Kit #45415 includes all parts marked with an asterisk (*). parts are not sold separately.

MOUNTING KIT INSTALLATION

CYLINDER ASSEMBLY #25247

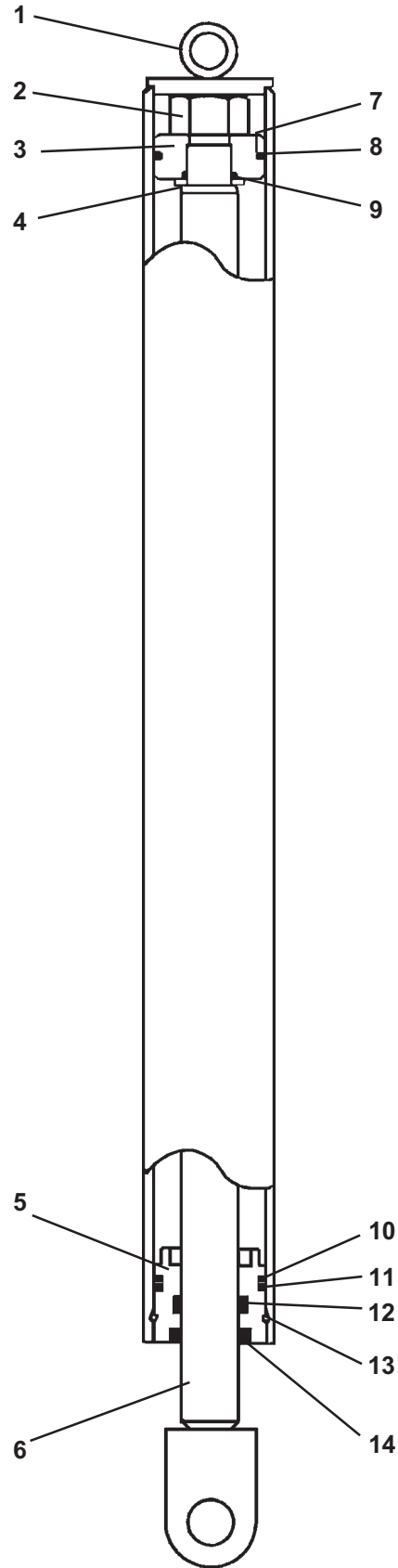

MOUNTING KIT INSTALLATION

CYLINDER ASSEMBLY #25247

<u>NO</u>	<u>REQ'D</u>	<u>PART NO.</u>	<u>DESCRIPTION</u>
1	1	25248	Cylinder Tube
2	1	1483	Hex Nut
3	1	50252	Piston
4	1	5421	Washer
5	1	62770	Cylinder Gland
6	1	25251	Cylinder Rod
7	1	4645*	O'Ring
8	1	4644*	Piston Ring
9	1	4641*	O'Ring
10	1	4509*	O'Ring
11	1	4510*	Back-Up Washer
12	1	45219*	PolyPak Seal
13	1	7165*	Cylinder Gland Retaining Ring
14	1	4974*	Rod Wiper

NOTE: Seal Kit #45258 includes all parts marked with an asterisk (*). parts are not sold separately.

MOUNTING KIT INSTALLATION

ELECTRICAL ASSEMBLY #25427

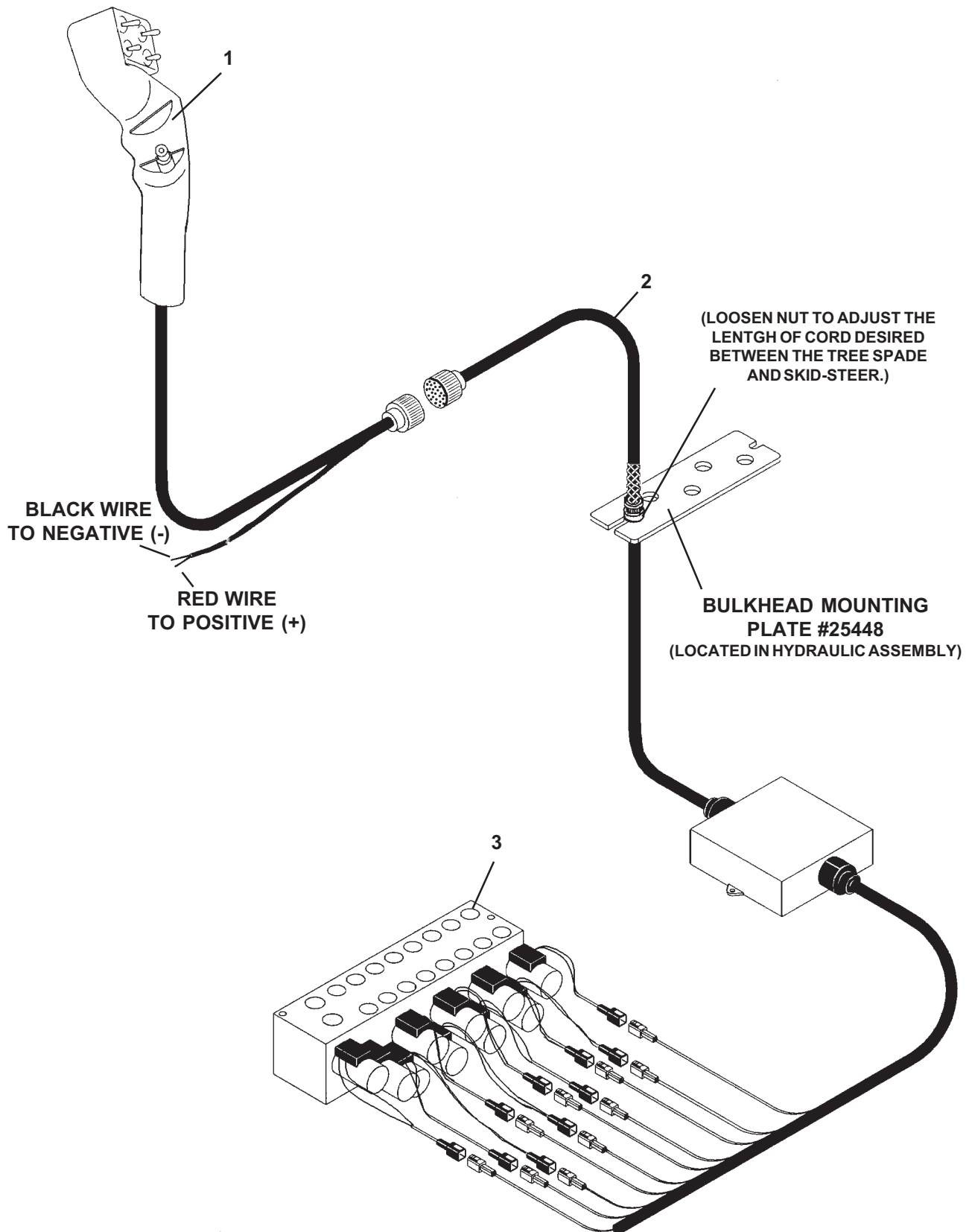

MOUNTING KIT INSTALLATION

ELECTRICAL ASSEMBLY #25427

<u>NO</u>	<u>REQ'D</u>	<u>PART NO.</u>	<u>DESCRIPTION</u>
1	1	25425	Joystick Assembly Includes Power Cord, Connector and Joystick
2	1	25455	Wire Harness Assembly Includes Power Cord, Connector and Junction Box
3	1	25456	Valve Assembly Includes Six Circuit Valve with #6 O'ring Ports, 26 GPM BiDirectional Unloader, 2200 PSI BiDirectional Relief Valve and Deutsch Connectors on Coils

VALVE ASSEMBLY

VALVE ASSEMBLY #25456

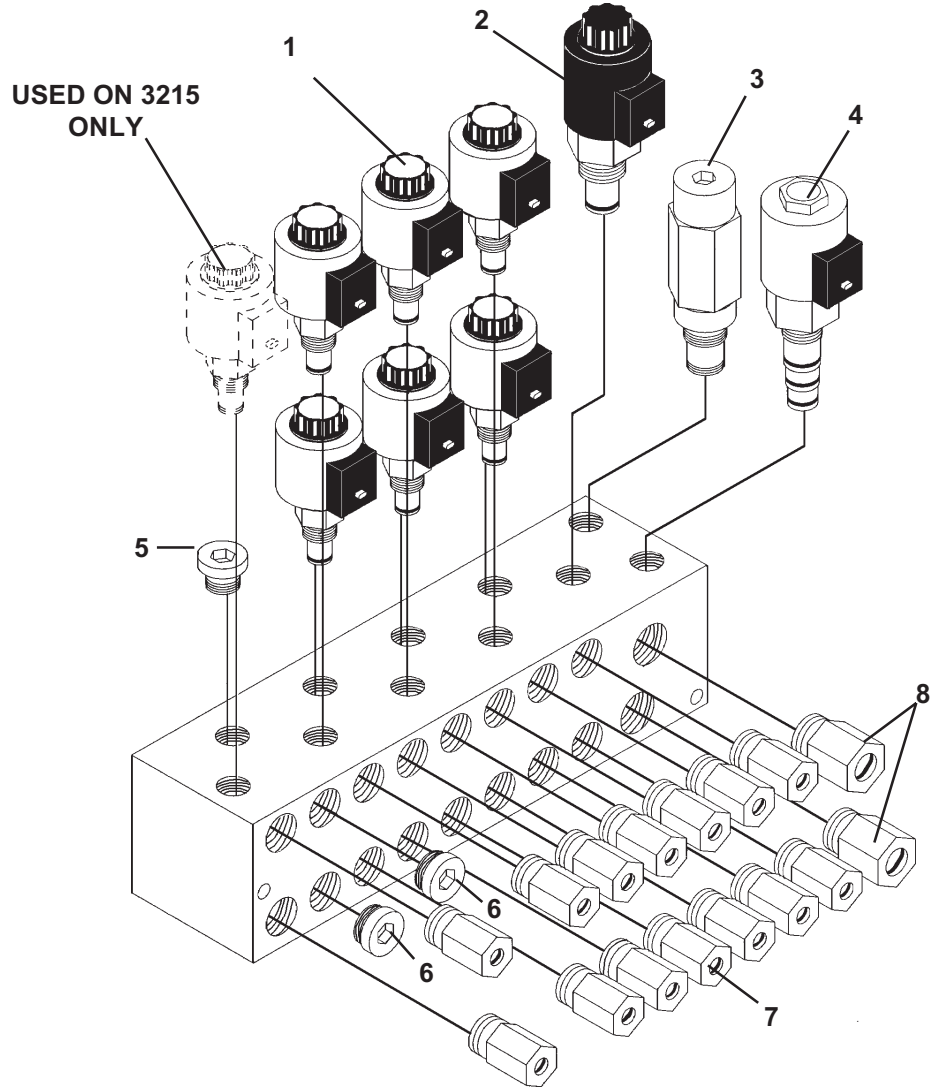

HYDRAULIC SCHEMATIC

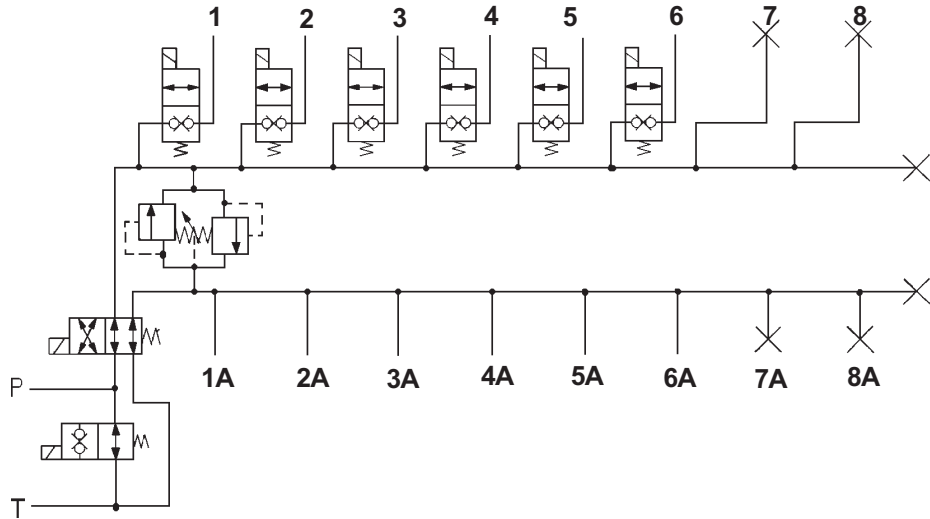

VALVE ASSEMBLY

VALVE ASSEMBLY #25456

<u>NO</u>	<u>REQ'D</u>	<u>PART NO.</u>	<u>DESCRIPTION</u>
1	6	45865	Circuit Control Spool Assembly - 2415
	6	45871	Coil Assembly
	7	45865	Circuit Control Spool Assembly - 3215
	7	45871	Coil Assembly
2	1	45867	Unloader Spool Assembly
	1	45872	Coil Assembly
3	1	45868	Relief Valve
4	1	45866	Reverse Spool Assembly
	1	45873	Coil Assembly
5	2	3341	Plug - 2415
	1	3341	Plug - 3215
6	4	3311	Plug - 2415
	2	3311	Plug - 3215
7	12	30348	Adapter - 2415
	14	30348	Adapter - 3215
8	2	30349	Adapter

FUNCTION	WIRE COLOR
FLOW REVERSER	BLACK / WHITE
UNLOADER	GREEN
REAR STABILIZER	ORANGE
BLADE #1	BLUE
BLADE #2	BLUE / BLACK
BLADE #3	ORANGE / BLACK
BLADE #4 (if equipped)	WHITE / BLACK
BLADE #5 (if equipped)	WHITE
GATE	RED / BLACK
UNDERCUTTER (if equipped)	GREEN / BLACK

SOLENOID VALVES

REPLACEMENT PARTS

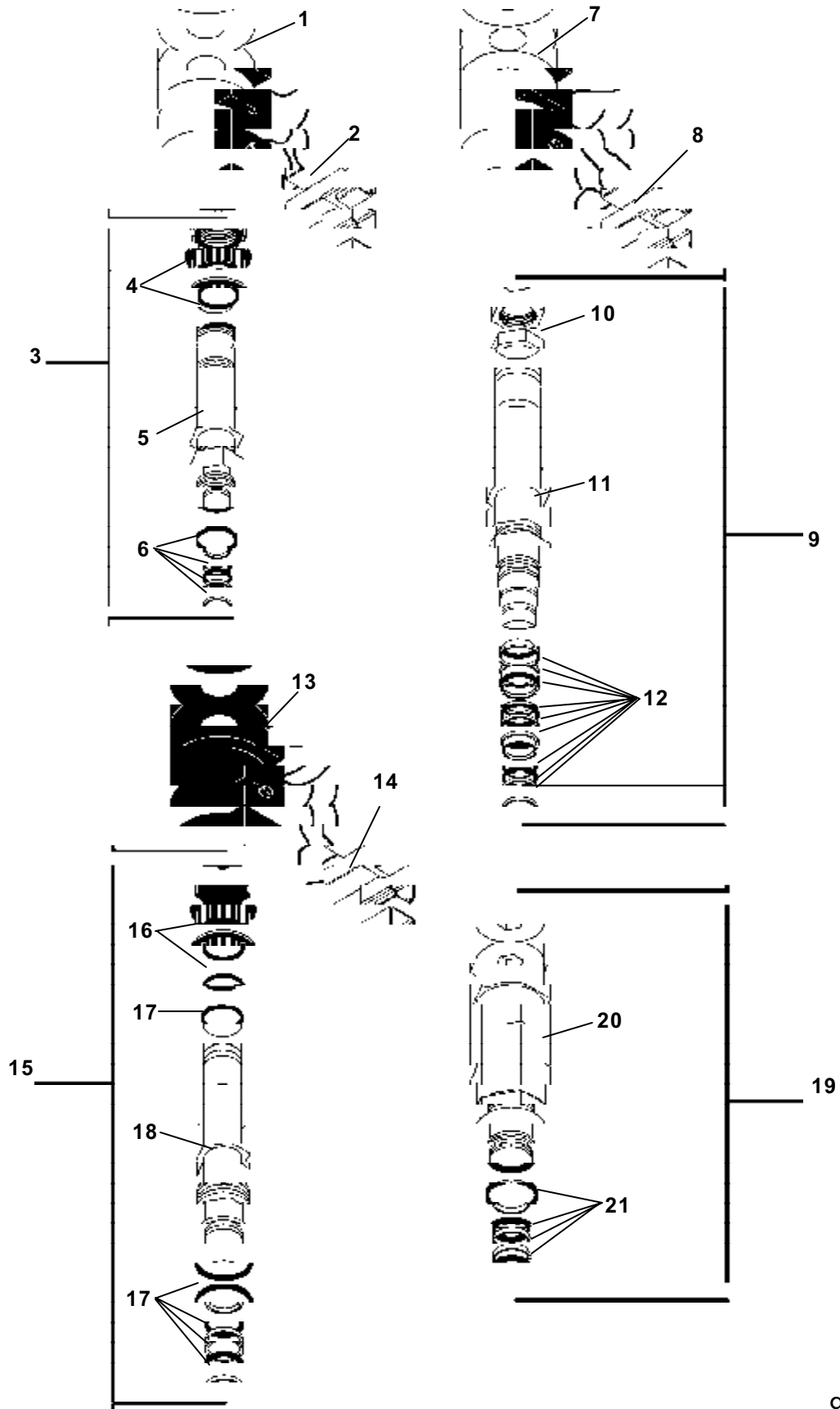

SOLENOID VALVES

REPLACEMENT PARTS

<u>NO</u>	<u>REQ'D</u>	<u>PART NO.</u>	<u>DESCRIPTION</u>
1	1	45871	Coil (Includes #2)
2	1	25550	Wire Terminal Connector
3	Varies	45865	Circuit Control Spool Assembly (Includes items #4, #5 & #6)
4	1	45869	Nut Assembly (Includes O'Ring)
5	-	----	Spool (Not Sold Separately)
6	1	45874	Replacement Seal Kit
7	1	45873	Coil (Includes #8)
8	1	25550	Wire Terminal Connector
9	1	45866	Reverse Valve Spool Assembly (Includes items #10, #11 & #12)
10	1	45830	Nut
11	-	----	Spool (Not Sold Separately)
12	1	45875	Replacement Seal Kit
13	1	45872	Coil (Includes #14)
14	1	25550	Wire Terminal Connector
15	1	45867	Unloader Spool Assembly (Includes items #16, #17 & #18)
16	1	45870	Nut Assembly (Includes O'Ring)
17	1	45876	Replacement Seal Kit
18	-	----	Spool (Not Sold Separately)
19	1	45868	Relief Valve (Includes items #20 & #21)
20	-	----	Relief Valve (Not Sold Separately)
21	1	45877	Replacement Seal Kit

WIRING SCHEMATIC

REPLACEMENT PARTS FOR JOYSTICK ASSEMBLY #25425

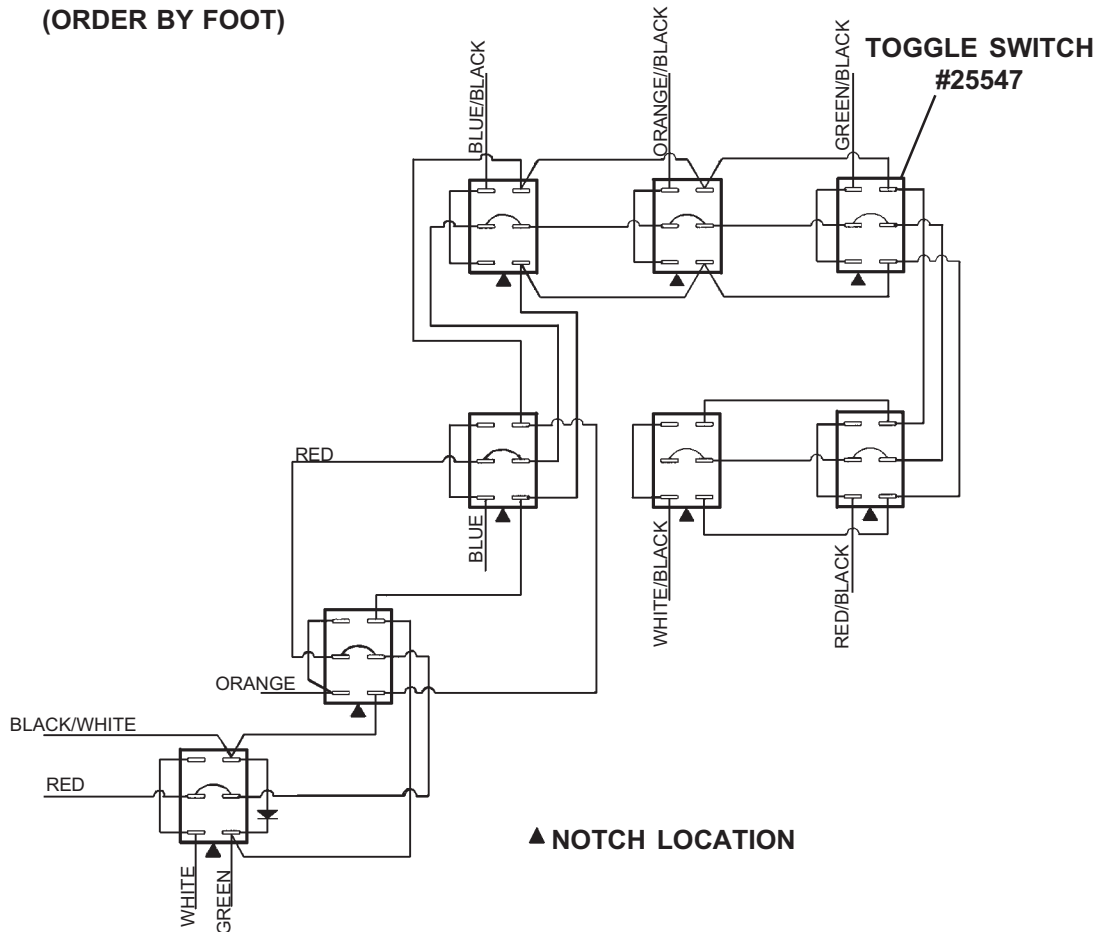
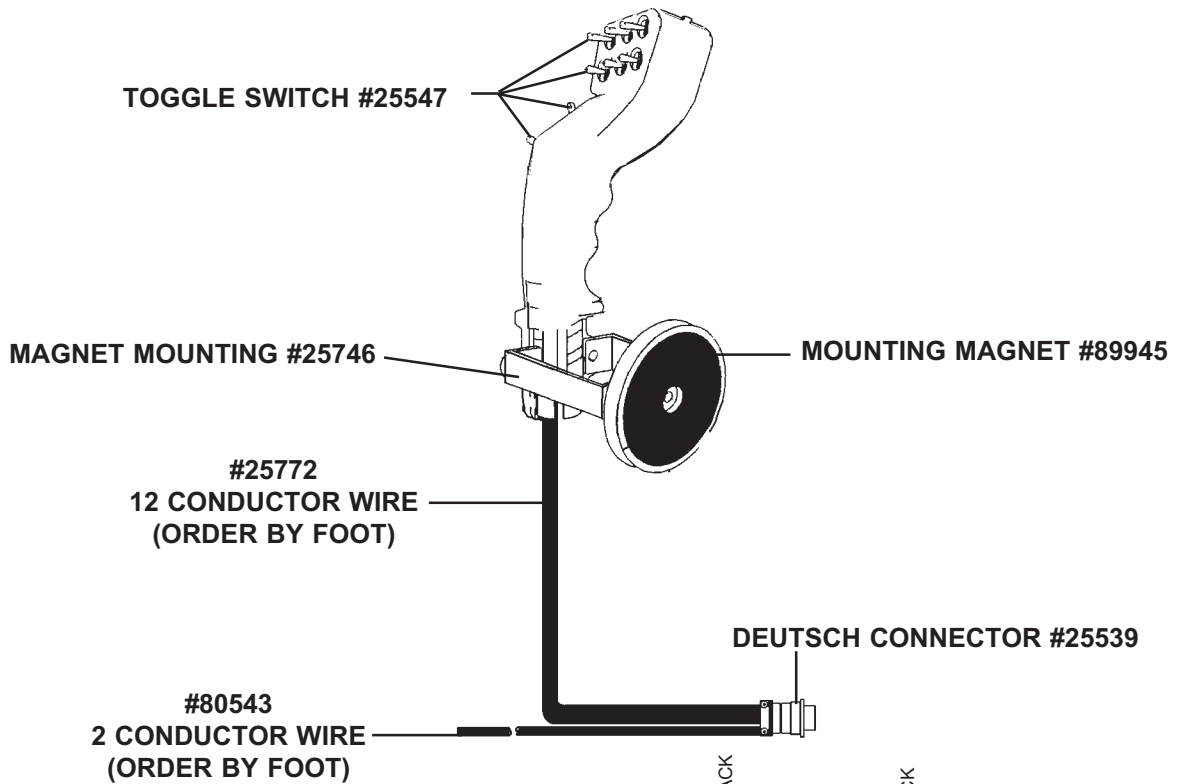

WIRING SCHEMATIC

REPLACEMENT PARTS FOR WIRE HARNESS ASSEMBLY #25455

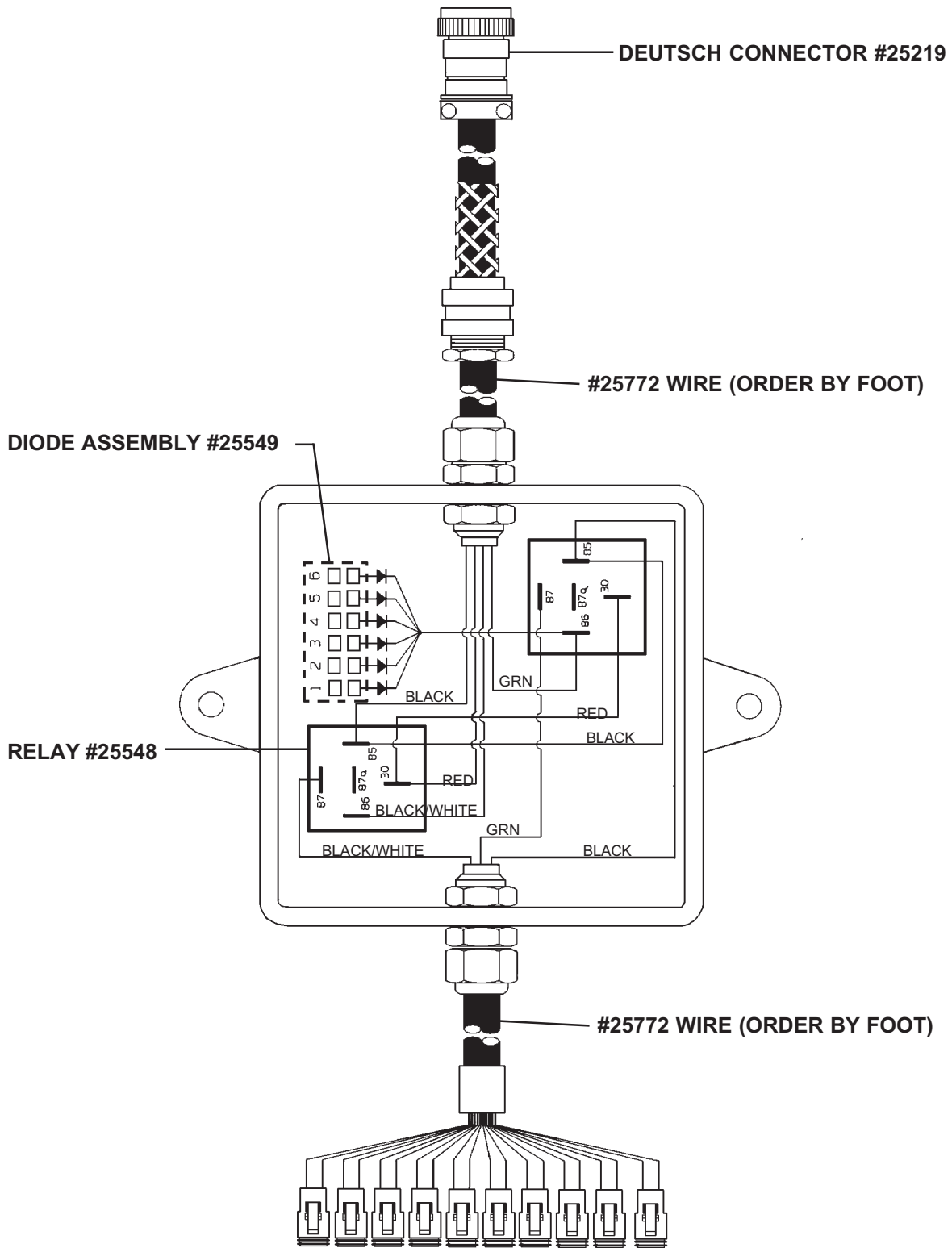

WIRE TERMINAL PLUG #25551
(INCLUDES: (2) SOCKETS, (1) PLUG & (1) WEDGE LOCK)

WIRING SCHEMATIC

12' EXTENSION CABLE ASSEMBLY #25519

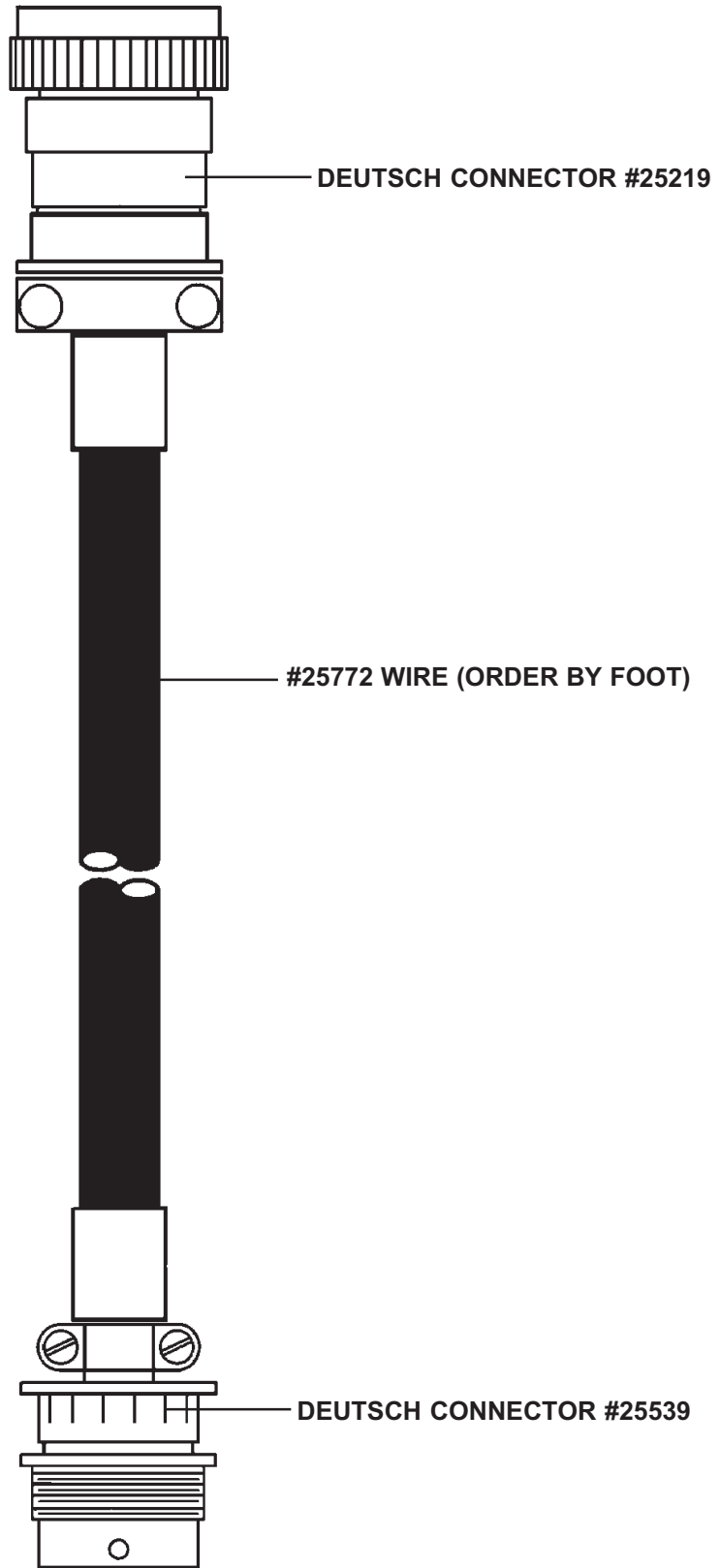

WIRING SCHEMATIC

DEUTSCH CONNECTORS

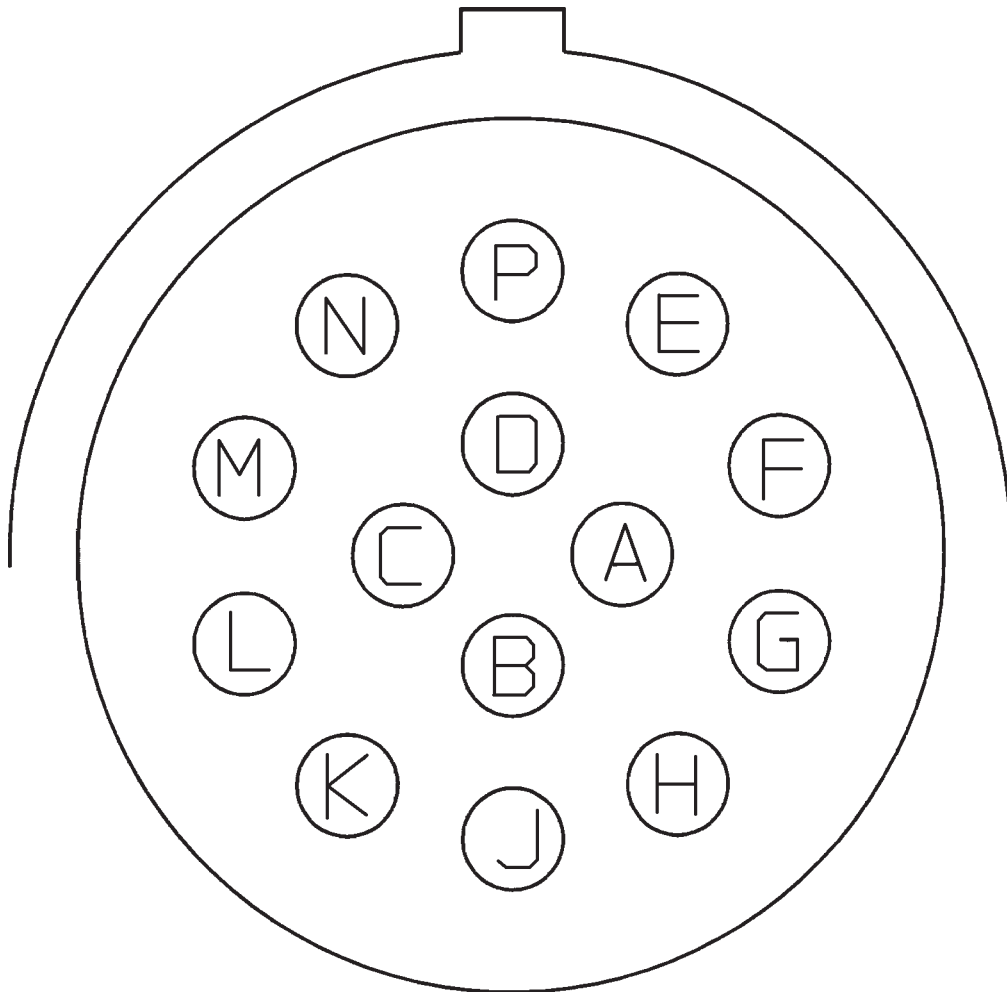
PIN OUT DETAIL

A = GREEN
B = BLACK
C = RED/BLACK
D = GREEN/BLACK
E = BLUE/BLACK
F = BLUE
G = WHITE/BLACK
H = ORANGE/BLACK
J = BLACK/WHITE
K = RED
L = ORANGE
M = WHITE
N = NOT USED
P = NOT USED

BLADE SETS
OPTIONAL BLADE KITS

2415 BLADES

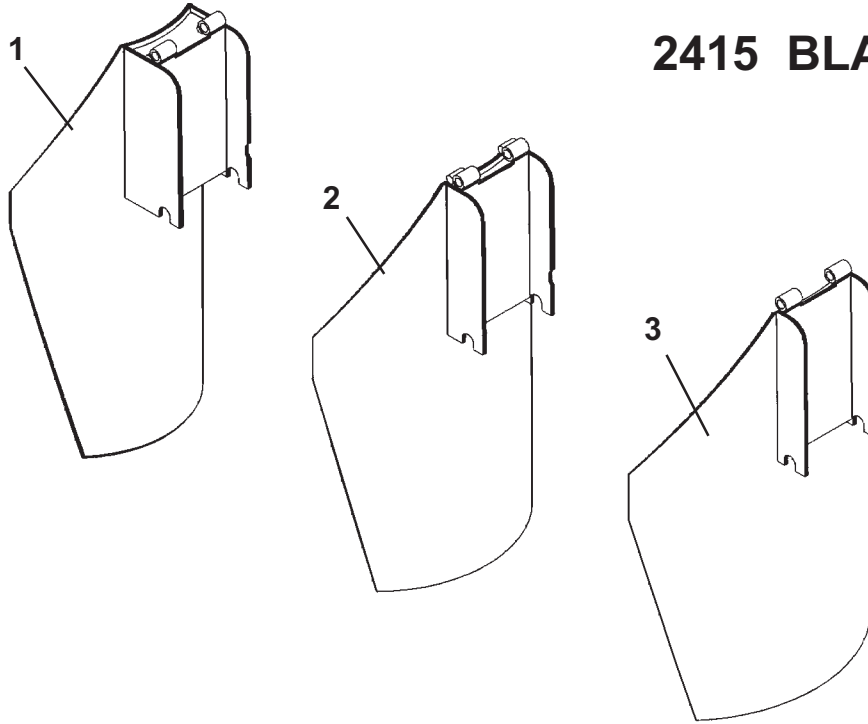

3215 BLADES

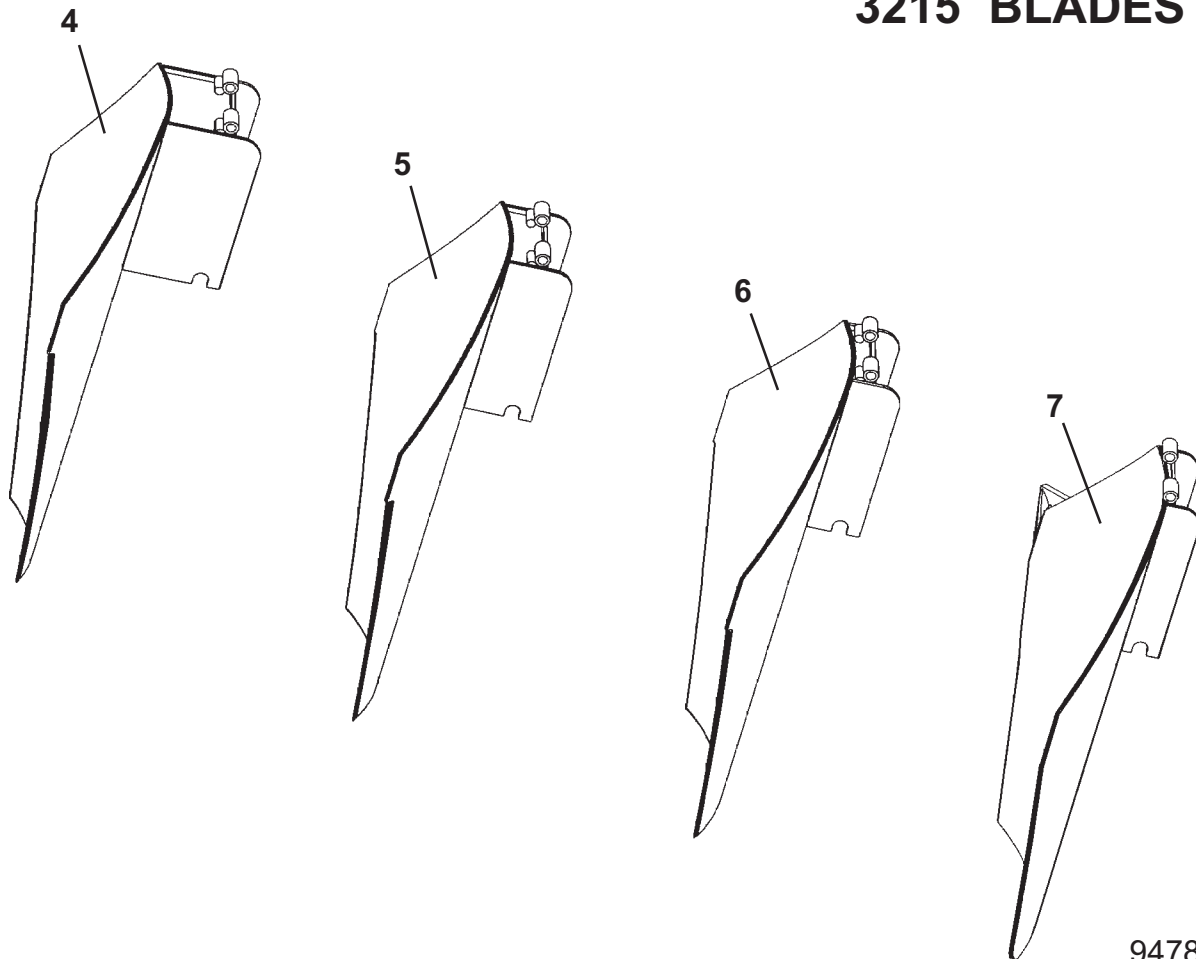

BLADE SETS

OPTIONAL BLADE KITS

<u>NO</u>	<u>REQ'D</u>	<u>PART NO.</u>	<u>DESCRIPTION</u>
1	1 -	25294 25297	16" Blade Kit - 2415 Tree Spade (Includes 3 Blades) 16" Replacement Blade
2	1 -	25295 25298	20" Blade Kit - 2415 Tree Spade (Includes 3 Blades) 20" Replacement Blade
3	1 -	25296 25299	24" Blade Kit - 2415 Tree Spade (Includes 3 Blades) 24" Replacement Blade
4	1 -	25045 25024	20" Blade Kit - 3215 Tree Spade (Includes 4 Blades) 20" Replacement Blade
5	1 -	25044 25023	24" Blade Kit - 3215 Tree Spade (Includes 4 Blades) 24" Replacement Blade
6	1 -	25043 25022	28" Blade Kit - 3215 Tree Spade (Includes 4 Blades) 28" Replacement Blade
7	1 -	25042 25021	32" Blade Kit - 3215 Tree Spade (Includes 4 Blades) 32" Replacement Blade

INSTALLATION INSTRUCTIONS

GENERAL INFORMATION

The following instructions will assist you in mounting your tree spade onto your skid-steer loader. The tree spade uses the quick attach mechanism for ease of installation. Therefore, if you know how to attach the loader bucket, attaching the tree spade should prove no problem.

NOTE: For mounting to other host machines see the specific mounting instructions that are supplied separately.

Remember to read all safety warnings, decals and operating instructions before operating the skid-steer loader or tree spade.

MOUNTING INSTRUCTIONS

1. Remove the steel shipping banding from around the tree spade and the skid.
2. Remove any attachment from the front of the skid-steer loader.
3. Set the quick attach locks on the skid-steer toolbar to the unlocked position. Lower the loader arms and tilt the toolbar down low enough to pass under the top lip of the hitch on the mainframe.
4. Following all standard safety practices, start the skid-steer and slowly drive it in back of the attachment. Position the loader so the top of the toolbar under the lip of the hitch on the mainframe.
5. Tilt the toolbar back to hook the attachment onto the toolbar. It may be necessary to lift the loader arms slightly.
6. Set the quick attach locks to the locked position to secure the tree spade onto the loader. It may be necessary to raise lower or tilt the toolbar to properly align so the locking mechanism can be activated.
7. Install your rear stabilizers (if so equipped) by following the instructions that were supplied rear stabilizers for your unit.
8. Connect the power and return hoses for the rear stabilizers to the two bulkhead fittings on the top of the mainframe (directly beside the power and return hoses for the tree spade).
9. With the auxiliary hydraulic system turned off, route the hydraulic hoses over the mainframe and connect them to their proper auxiliary couplers on the loader.
10. Connect the cord assembly (with joystick) to the control cord from the tree spade. Connect the power cord from the joystick control to a power source on the skid-steer.

NOTE: Some host machines have an auxiliary electrical outlet to plug in the control cord and then use their own joystick controls.

DANGER!



ELECTROCUTION HAZARD

Provide electrical power to the joystick by following your skid-steer manufacturer's recommended procedures. The electrical circuit must be fused with a 10 amp fuse to prevent machine damage and serious personal injury or death.

11. The length of control cord extending from the tree spade mainframe to the skid-steer can be adjusted to suit the reach required for your application. (To adjust: Loosen the nut on the strain relief fitting to release the grip of the grommet and either push or pull on the cord to obtain your desired length. Tighten the nut by hand to secure the cord in place. Use plastic ties to secure the control cord to the hydraulic hoses to help keep it from interfering with operation of the tree spade and also to assist in keeping it free from pinching or chafing.)
12. Complete the pre-delivery checklist located in the back of this manual (Section R). Tree Spade installation is now complete.

OPERATING INSTRUCTIONS

CONTROLS

GENERAL INFORMATION

Your tree spade is controlled by a joystick and an electrical valve assembly. Although BRADCO does offer various options for connecting to existing electrical joystick controls we will be covering the BRADCO operating controls in these instructions. The joystick control consists of 8 momentary toggle switches and is equipped to handle up to five blades, the undercutter, gate and rear stabilizers (if equipped).

BLADE CONTROLS

The joystick control can accommodate up to five blades and is wired for the number of blades on the tree spade you have purchased. Pushing the toggle switch up will raise that specific blade up and pushing the toggle switch down will lower that blade. When the toggle switch is released all movement will stop. If you have purchased a Model 2415, the switches for blades number 4 and 5 will be "inoperable". The blade controls are located in the same pattern as the blades on the unit with blade number 1 being the closest blade to the operator on the left hand side (left rear blade).

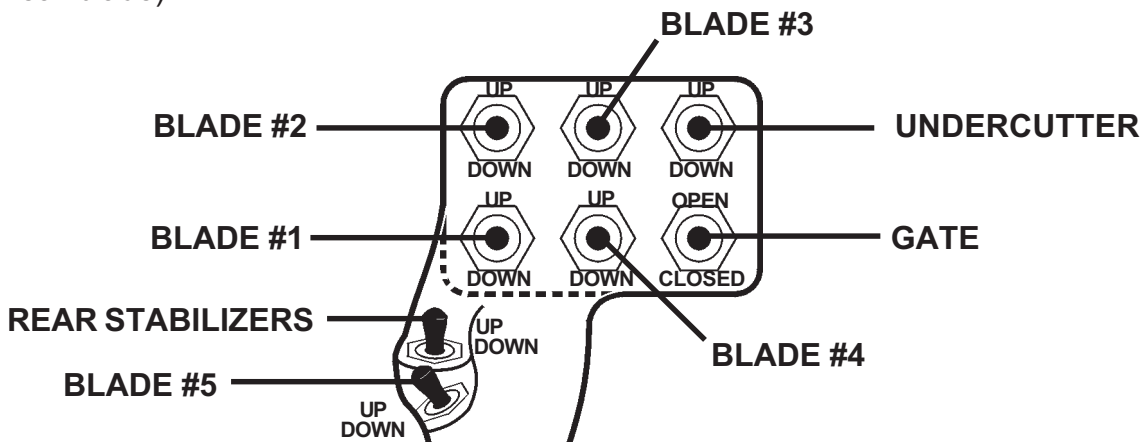

UNDERCUTTER CONTROL

The undercutter control operates in the same fashion as the blade controls. Pushing the toggle switch up will raise undercutter up and to the rear of the unit and pushing the toggle switch down will lower the undercutter, therefore cutting the roots under the tree or shrub. When the toggle switch is released all movement will stop. The undercutter is a very important feature of the BRADCO Tree Spades. Using the undercutter will cut the roots at the bottom of the ball instead of stretching and then snapping them. Cutting the roots will enhance regrowth and eliminate the need to prune the root ends. The undercutter also limits compaction of the ball and adds support under the ball for transporting or when digging in looser sandy soil.

GATE CONTROL

The gate control operates in the same fashion as the blade controls. Pushing the toggle switch up will open the gates (left and right arms) and pushing the toggle switch down will close the gate. When the toggle switch is released all movement will stop.

OPERATING INSTRUCTIONS

CONTROLS

REAR "JACK" STABILIZER CONTROL

The rear stabilizer control operates in the same fashion as the other controls. Pushing the toggle switch up will raise the left and right stabilizers and pushing the toggle switch down will lower the left and right stabilizer. When the toggle switch is released all movement will stop.

Rear stabilizer kits are available from your BRADCO dealer for fitup to various skid-steer loaders. The rear stabilizer hoses connect to the tree spade control valve and are therefore controlled by the operating control switch on the joystick.

Rear stabilizers are recommended to get the maximum performance from your tree spade. The rear stabilizers allow as much weight as possible to be transferred to the front of the skid-steer and therefore to the tree spade for maximum digging ability.

GENERAL INFORMATION

The following information will assist you in determining the size of ball needed for the job at hand. These charts (*taken from the American Standard for Nursery Stock - ANSI Z60.1-1996*) are to be used as a guideline only and you should contact your local nursery for more detailed instructions.

Multi-Stem Trees or Shrubs		Deciduous Shrubs		Shade Trees	
Height	Min. Dia. Ball	Height	Min. Dia. Ball	Caliper	Min. Dia. Ball
4'	14"	12"	8"	1/2"	12"
5'	16"	18"	9"	3/4"	14"
6'	18"	2'	10"	1"	16"
7'	20"	3'	12"	1-1/4"	18"
8'	22"	4'	14"	1-1/2"	20"
10'	24"	5'	16"	1-3/4"	22"
12'	28"	6'	18"	2"	24"
14'	32"	7'	20"	2-1/2"	28"
16'	38"	8'	22"	3"	32"
18'	42"	9'	24"	3-1/2"	38"
		10'	26"	4"	42"

Small Trees (Ht. up to 6' / Caliper 6' & over)		Coniferous Evergreens Spreading/Semi-Spreading/Globe/Dwarf		Coniferous Evergreens Conical & Broad Uprights	
Ht./Caliper	Min. Dia. Ball	Spread	Min. Dia. Ball	Height	Min. Dia. Ball
2'	10"	9"	8"	12"	10"
3'	12"	12"	8"	18"	10"
4'	14"	15"	10"	2'	12"
5'	16"	18"	10"	3'	14"
3/4"	16"	2'	12"	4'	16"
1"	18"	2-1/2'	14"	5'	20"
1-1/2"	20"	3'	16"	6'	22"
1-3/4"	22"	3-1/2'	18"	7'	24"
2"	24"	4'	21"	8'	27"
2-1/2"	28"	5'	24"	9'	30"
3"	32"	6'	28"	10'	34"
3-1/2"	38"	7'	32"	12'	34"
4"	42"	8'	36"	14'	42"

OPERATING INSTRUCTIONS

Columnar Coniferous Evergreens Regular Growing

Height	Min. Dia. Ball
12"	10"
18"	10"
2'	12"
3'	13"
4'	14"
5'	16"
6'	18"
7'	20"
8'	22"
9'	24"
10'	27"
12'	30"
14'	33"
16'	36"
18'	40"

Columnar Coniferous Evergreens Rapid Growing

Height	Min. Dia. Ball
12"	8"
2'	9"
3'	11"
4'	12"
5'	14"
6'	16"

Broadleaf Evergreen Cone and Upright

Height	Min. Dia. Ball
18"	10"
2'	12"
3'	14"
4'	16"
5'	20"
6'	22"
7'	24"
8'	27"
9'	30"
10'	34"
12'	38"
14'	42"

Broadleaf Evergreen Spreading/Semi-Spreading/ Globe/Dwarf

Spread	Min. Dia. Ball
18"	10"
2'	12"
2-1/2'	14"
3'	16"
3-1/2'	18"
4'	21"

Processed Balled Fruit Trees

Caliper	Min. Dia. Ball
1/4"	8"
5/16"	8"
3/8"	10"
3/2"	10"
5/8"	10"
3/4"	12"
1" & UP	12"

In sizing shade trees, caliper shall take precedence over height. In size grading small and flowering trees, height shall take precedence up to 6 feet; thereafter, caliper takes precedence.

Caliper of the trunk shall be taken 6 inches above the ground up to and including 4 inch caliper size, and 12 inches above the ground for larger sizes. (Seldom are tree trunks perfectly round. Caliper measurement may be taken with "slot" type caliper, "pincer" type calipers or diameter tape.)

The diameter of the ball is determined by the blade size or the digging depth. Each blade is changed by removing one pin. The ball depth is determined by the position of the adjustable legs.

On larger bushy trees the branches may have to be tied up so the blades do not cut off the lower branches.

On some types of trees it is recommended for best results that transplanting take place while the tree is dormant. Contact your local nursery for the specifications on the type of tree you are transplanting.

OPERATING INSTRUCTIONS

The BRADCO Tree Spades are designed to meet the needs of the professional nurseryman. The machine has proven capable of continuous digging with a minimum of maintenance. It is used extensively for removing trees for burlapping and for transplanting and rearranging nursery rows.

NOTE: These instructions include the use of rear "jack" stabilizers. Rear stabilizer kits are available from your BRADCO dealer for fitup to various skid-steer loaders. The rear stabilizer hoses connect to the tree spade control valve and are therefore controlled by the operating control switch on the joystick. Rear stabilizers are recommended to get the maximum performance from your tree spade. The rear stabilizers allow as much weight as possible to be transferred to the front of the skid-steer and therefore to the tree spade for maximum digging ability.

IMPORTANT: Always follow the instructions in your skid-steer loader operators manual for operating the auxiliary hydraulic controls and follow the Safety Shutdown Procedure whenever leaving the operators station of the skid-steer.

After the tree spade has been properly attached, raise the unit above the ground approximately 2 feet. Acquaint yourself with the various control levers. After becoming familiar with the controls it is advisable to dig in soil without a tree. This will provide an opportunity to check ball size as well as attachment operation.

The blades on the tree spade are number 1, 2, 3 and 4 (if so equipped). The two forward blades open when the gate control is pushed forward. The gates will open and close together.

Soil condition and type affect how the tree spade operates. In firm soil the blades may only travel only one-third of the way down on the first stroke and in loose or sandy soil the blades may penetrate completely in one stroke.

The amount of root ball needed will vary per the diameter of the tree trunk, the height of the tree or the type of tree. Refer to the charts at the beginning of this section. A general rule of thumb is every one inch of tree diameter requires a minimum of ten inch ball diameter.

Adjusting Leg Height

The tree spades are equipped with adjustable legs that are used for adjusting the ball size. With the legs fully raised the ball size will be the rated size of your tree spade. Moving the legs down will decrease the ball size approximately 1.50" for each adjustment hole. If the legs are removed completely the tree spade will dig a slightly larger hole than rated size.

Lift and block the spade before making any leg adjustment.

OPERATING INSTRUCTIONS

Balled and Burlapped Trees (with or without Wire Basket)

NOTE: There is a wide range of presewn burlap bags, wire baskets and containers available from reputable manufacturers for the BRADCO Tree Spade.

Determine the size of ball required for the type and size of tree. Install the correct blades and adjust the legs to achieve the desired ball size.

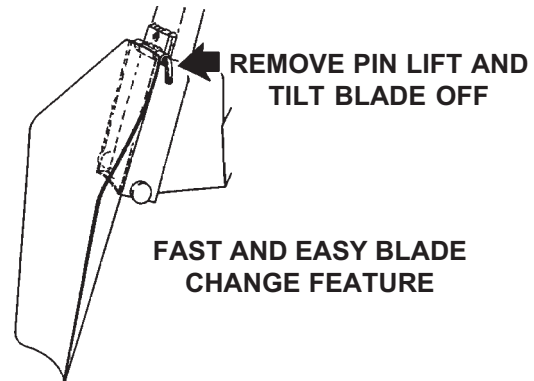

1. With the gates open and the blades in the up position, center the tree in the tree spade from left to right. Positioning the spade front to back can be accomplished by aligning the tree with the undercutter pivot pin which is at the center of the ball. **NOTE: It is CRITICAL that the tree is centered in the ball. Therefore it is advisable to have someone on the ground to aid in the alignment process.**
2. Close the gate.
3. Lower the loader arms, therefore raising the front wheels off the ground.
4. Lower the rear stabilizers (if so equipped) until the loader feels level.

NOTE: Raising the loader until the wheels are only slightly off the ground transfers the weight to the tree spade for maximum digging power. Lifting the loader too high may cause an unstable condition.

5. Tilt the tree spade until it is level.
6. Once the tree spade is level, the loader raised slightly and the gate closed, it is time to start lowering the blades. Using the joystick control, lower "Blade 1" as far as it will go into the soil. (Due to the different soil conditions the blade may go all the way into the ground or only slightly.)
7. As soon as the blade starts to tilt the attachment, stop movement and raise the blade slightly to remove some of the down pressure. (This will assist in digging the maximum ball size and prevent digging an angled hole.)
8. Using the joystick control, lower "Blade 2" as far as it will go into the soil. As soon as the blade starts to tilt the attachment, stop movement and raise the blade slightly to remove some of the down pressure.
9. Repeat step #8 for "Blade 3" and "Blade 4" (if so equipped).

10. If the blades failed to lower completely due to the soil conditions, repeat Steps #6 thru #9 until all the blades are completely lowered into the soil.

11. Activate the undercutter which will pass beneath the blades, cutting all roots and therefore completely freeing the ball and producing a slightly rounded bottom.

12. Retract the undercutter to the center position of the ball before lifting. This will assist in maintaining the ball in some soil types.

13. Raise the rear stabilizers (if so equipped).

14. Raise the loader arms until the wheels are fully on the ground.

15. Lift the tree out of the hole.

16. Placing the burlap on the ground or in the wire basket, position the tree in the center of the burlap. **NOTE: Carry the tree as low as possible when transporting.**

17. Raise the undercutter and while keeping the tree trunk as vertical as possible, lower the tree. Due to the curved bottom, the ball appears to "push up," separating itself from the blades without disturbing the smooth sides of the ball.

18. Release the ball by first raising "Blade 4" and continue to raise the blades in reverse order 3, 2, & 1. **NOTE: If the tree ball sticks to the blades, use a shovel to press down on the tree ball to loosen it from the blades.**

19. Lift the tree spade slightly and open the gates. Back the loader away from the tree. The ball is ready for covering with no additional shaping necessary.

20. Finish wrapping the tree.

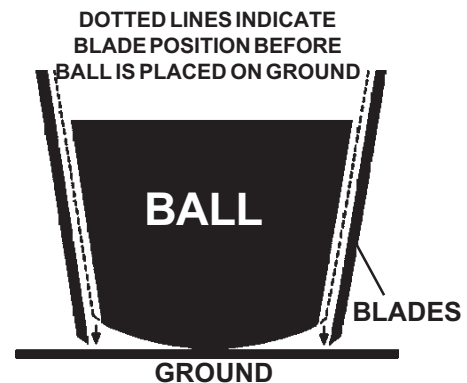
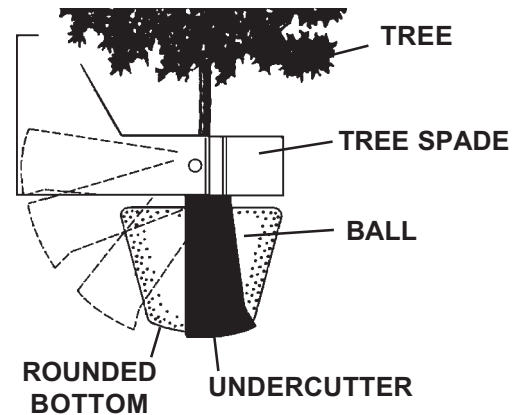

Direct Transplanting

1. Determine the size of hole needed for the tree you are transplanting. Install the correct blades and adjust the legs to achieve the desired hole size.

OPERATING INSTRUCTIONS

2. Raise the blades and drive the skid steer to the location that the tree will be planted and position the skid-steer so the loader is as level as possible. Follow Steps 2 thru 14 in the previous instructions (Balled and Burlapped Trees) to dig a spot for the tree..
3. Lift the dirt ball out of the ground and move out of the way for tree transplanting. Set the tree spade on the ground and raise the blades to release the dirt ball. The blades should be raised in reverse order 4, 3, 2 and 1. Open gates.
4. See Steps 1 thru 15 in the previous instructions (Balled and Burlapped Trees) to dig up the desired tree for transplanting.
5. Position the tree over the previously dug hole, raise the undercutter and while keeping the tree trunk as vertical as possible, lower the tree. Due to the curved bottom, the ball appears to "push up," separating itself from the blades without disturbing the smooth sides of the ball.
6. Release the ball by first raising "Blade 4" and continue to raise the blades in reverse order 3, 2, & 1. **NOTE: If the tree ball sticks to the blades, use a shovel to press down on the tree ball to loosen it from the blades.**
7. Lift the tree spade slightly and open the gates. Back the loader away from the tree. NOTE: Follow any specific transplanting instructions, such as watering and mulching etc., for the type of tree you are transplanting.

LUBRICATION

GENERAL INFORMATION

Economical and efficient operation of any machine is dependent upon regular and proper lubrication of all moving parts with a quality lubricant. Neglect leads to reduced efficiency, wear, breakdown and needless replacement of parts. If any grease fittings are missing, replace them immediately. Clean all fittings thoroughly before using grease gun.

IMPORTANT: Avoid excessive greasing. Dirt collects on exposed grease and greatly increases wear. After greasing, wipe off excessive grease from fittings.

EVERY FOUR HOURS OF OPERATION OR AS NEEDED

- 2) Fittings on the back of each Slider "wear" Bar. (16) 3215, (12) 2415)
- 1) Fitting on the front of each Slide Channel. (4) 3215, (3) 2415)

NOTE: A scraping sound during blade operation is an indication that the slide channel and slider bars require lubricating.

EVERY EIGHT HOURS OF OPERATION

- 1) Fitting on Left Undercutter Pivot.
- 1) Fitting on Right Undercutter Pivot.
- 1) Fitting on each Gate Pivot Pins. (2)
- 1) Fitting on each Undercutter Cylinder Pivot Pin. (4)

LUBRICATION SYMBOLS



Lubricate twice daily or every 4 hours of operation with SAE Multi-Purpose Lubricant or an equivalent SAE Multi-Purpose type grease.



Lubricate daily or every 8 hours of operation with SAE Multi-Purpose Lubricant or an equivalent SAE Multi-Purpose type grease.

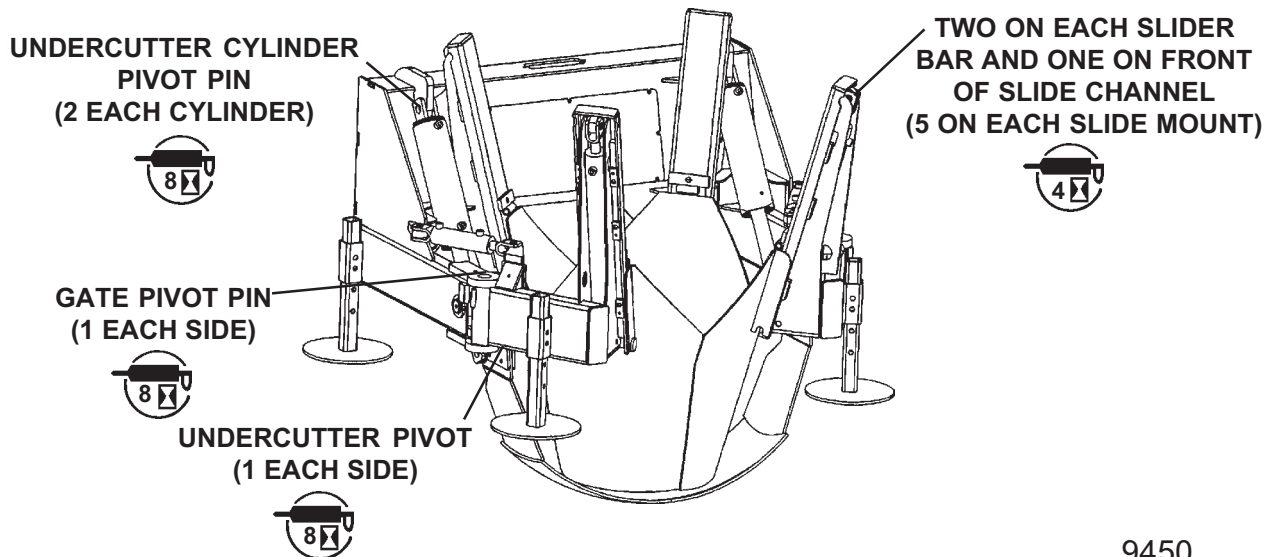

MAINTENANCE & SERVICE

GENERAL INFORMATION

Regular maintenance is the key to long equipment life and safe operation. Maintenance requirements have been reduced to an absolute minimum. However, it is very important that these maintenance functions be performed as described below.

LUBRICATION

Lubricate all grease fittings with a multi-purpose grease. For grease locations, refer to Section H.

DAILY

Physically check all pins, bushings, cotter pins, nuts, etc., for signs of wear or loose fit. Tighten as required, replace where necessary.

Clean equipment of all dirt, oil, and excess grease.

Check for missing or illegible Safety / Warning Decals.

Check all fittings and hydraulic hoses for leaks.

WARNING! Escaping hydraulic / diesel fluid under pressure can penetrate the skin causing serious injury. Fluid escaping from a very small hole can be almost invisible. Use a piece of cardboard or wood, rather than hands to search for suspected leaks.



Keep unprotected body parts, such as face, eyes, and arms as far away as possible from a suspected leak. Flesh injected with hydraulic fluid may develop gangrene or other permanent disabilities. If injured by injected fluid, see a doctor at once.

Stop the engine and relieve pressure before connecting or disconnecting lines.

Tighten all connections before starting engine or pressurizing lines.

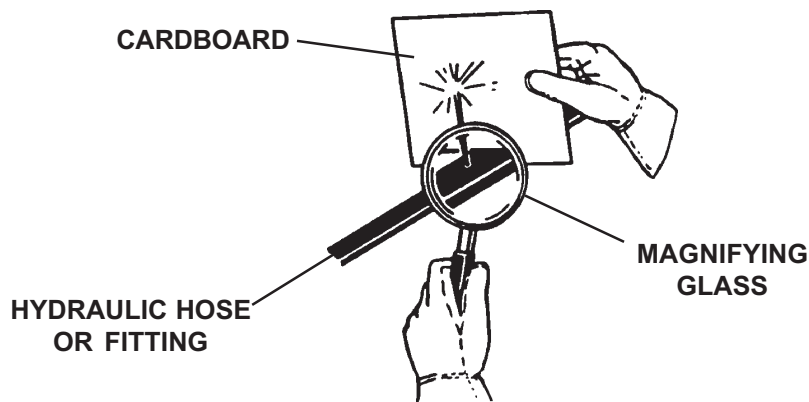

MAINTENANCE & SERVICE



WARNING! Be sure to follow Safety Shutdown Procedures before performing any maintenance on attachment.

BLADE MAINTENANCE

Maintaining the condition of the blades will result in a cleaner ball and a smoother digging operation. The blades are painted with a graphite coating before shipping and should be rubbed lightly with fine steel wool before using. This coating prevents the earth from sticking to the blades and aids in the digging operation. The life of the coating is affected by soil conditions and can be repainted with Slip Plate #1, manufactured by Acrotech Industries Inc. One gallon of Slip Plate #1 is supplied with all new units and can be purchased from BRADCO under part #25154. It is important that oil not be used on the blades as long as the graphite coating remains.

SHARPENING BLADES AND UNDERCUTTER

Although the blades and the undercutter should remain in good condition for a long time, extensive use and rocky soil conditions may dull portions of the blades or the undercutter. If sharpening is required use a hand grinder and sharpen the blades or undercutter surface in an even pattern.

REPLACING BUSHINGS

To Replace Left and Right Arm Bushings:

1. Lower the mainframe onto the rear legs as close to the ground as possible and block up the front of the mainframe to keep it level.
2. Remove Blades #2 and #3.
3. Disconnect the gate cylinders at the arm weldments.
4. Attach a hoist to the left arm to prevent it from falling and causing personal injury or undue stress to the hoses when it is disconnected from the mainframe.

NOTE: If you are removing the arm completely for bushing replacement the blade cylinder hoses will need to be tagged and removed.

5. With the arm supported remove the pivot pin securing the left arm to the mainframe. While continuing to support the arm, press out the top and bottom bushing and replace with new.
6. Position the arm and replace the pivot pin.
7. Connect the gate cylinder to the arm weldment.
8. Repeat steps #3 through #7 for the right arm.
9. Reinstall Blades #2 and #3.
Bushings replacement is complete.

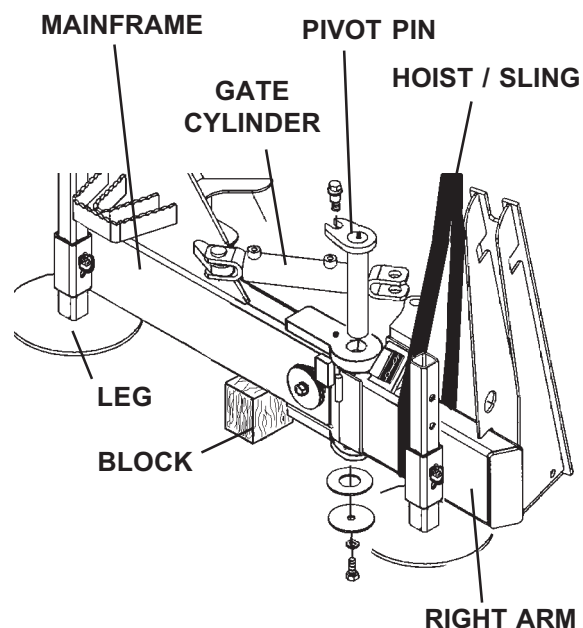

To Replace Left and Right Undercutter Pivot Bushings:

1. With the undercutter completely raised and all legs in their top position, lower the mainframe onto the legs to support it for maintenance.
2. With the mainframe supported by the legs lower the undercutter until it is resting on the ground.
3. Unbolt the left and right pivots from the undercutter blade and mainframe.
4. Rotate pivots forward. Using a hoist rotate the undercutter up until the left and right pivots can be removed from the mainframe.
5. Press the bushings out of the mainframe and replace with new.
6. Reinstall the left and right pivots into the mainframe.
7. Rotate the pivots and the undercutter until the attaching holes are aligned and install the existing hardware.

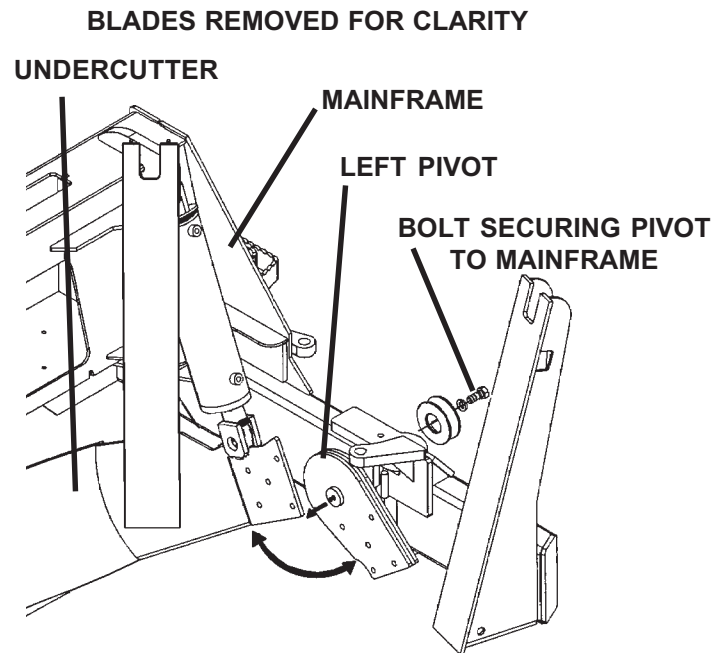

TO REMOVE PIVOT: ROTATE UNDERCUTTER BACK AND PIVOT FORWARD

Bushing replacement is complete.

SLIDE CHANNEL ADJUSTMENT

The slide channels are field adjustable to maintain a snug fit between the blade mounting channel and the blade rail. This will control both the side to side and the in and out play of the blade. The adjustments can be made with minimum tools and time and with no cutting or welding.

NOTE: It is recommended that the blade be removed for convenience.

To Adjust Side/Side Movement:

1. Using a 6" snap ring pliers, remove the pivot pin securing the top of the blade cylinder to the slide channel to gain access to the adjustment window in the slide rail tower.
2. Use a hex key wrench to turn the setscrews (#1573) clockwise to draw the slide bars on each side against the blade rail plates. Once the setscrews have been tightened back off 3/4 turn.
3. Using a hoist, raise the slide channel to gain access to the middle set of setscrews. Repeat Step #2.

MAINTENANCE & SERVICE

4. Using the hoist, raise the slide channel to access the third and final set of setscrews and repeat Step #2.
5. Slide the channel up and down to locate any binding. Readjust if necessary.
6. Position the blade cylinder and reinstall the pivot pin.

To Adjust In/Out Movement:

1. Position the slide channel completely down on the blade rail towers.
2. Loosen the hex nuts (#1226) located on the .38" UNC X 1.00" bolts (#1043) on the back of the slide channels.
3. Adjust the bolts clockwise to tighten the slide bar against the back side of the blade rail towers. Once the bolts have been tightened back off 3/4 turn and slide the channel up and down to locate any binding. Readjust if necessary.
4. When adjustment is completed, tighten the hex nut to lock the bolts in position.

NOTE: There will be extra play in the slide channels when they are in the uppermost position.

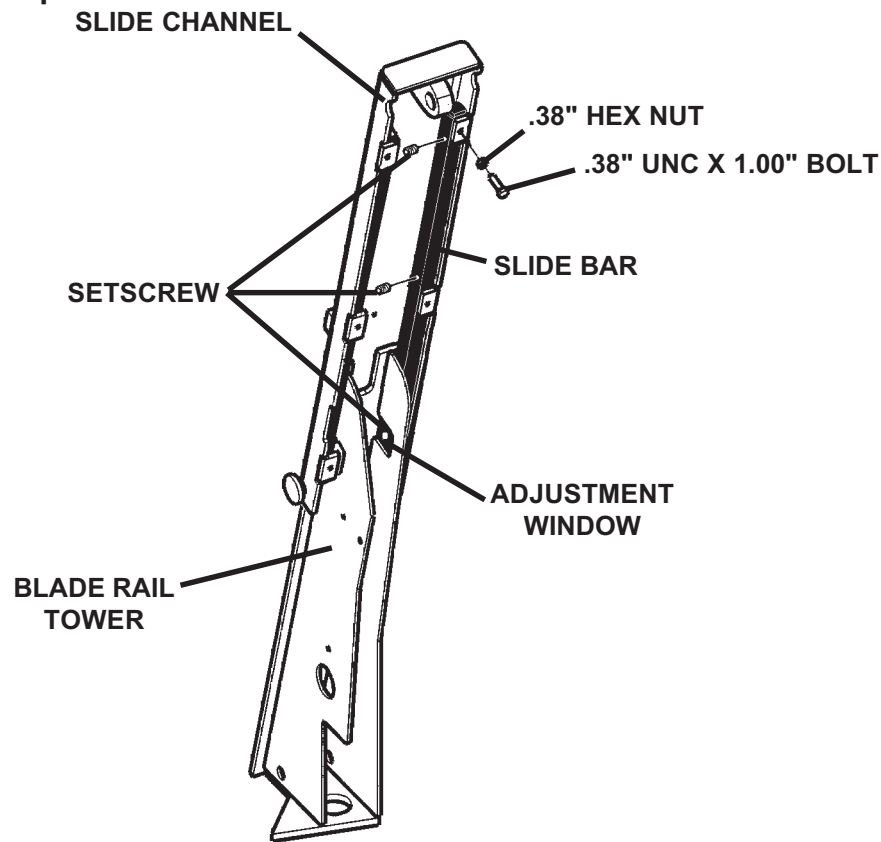

MAINTENANCE

CYLINDER SEAL REPLACEMENT

CYLINDER SEAL REPLACEMENT

GENERAL INFORMATION

The following information is provided to assist you in the event you should need to repair or rebuild a hydraulic cylinder. When working on hydraulic cylinders, make sure that the work area and tools are clean and free of dirt to prevent contamination of the hydraulic system and damage to the hydraulic cylinders.

Always protect the active part of the cylinder rod (the chrome section). Nicks or scratches on the surface of the rod could result in cylinder failure. Clean all parts thoroughly with a cleaning solvent before reassembly.

DISASSEMBLY PROCEDURE

IMPORTANT: Do not contact the active surface of the cylinder rod with the vise. Damage to the rod could result.

THREADED TYPE GLAND

1. Rotate the gland with a spanner wrench counter-clockwise until the gland is free of the cylinder tube.

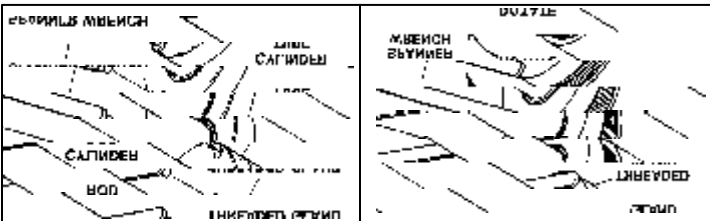

2. Pull the cylinder rod from the cylinder tube.
3. Inspect the piston and the bore of the cylinder tube for deep scratches or galling. If damaged, the piston and cylinder tube must be replaced.

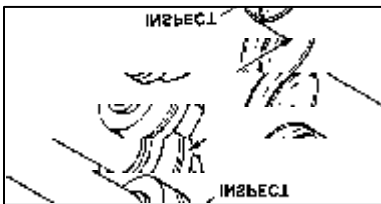

4. Remove the hex nut, piston, flat washer or spacer tube (if so equipped), and gland from the cylinder rod. If the cylinder rod is rusty, scratched, or bent, it must be replaced.
5. Remove and discard all the old seals.

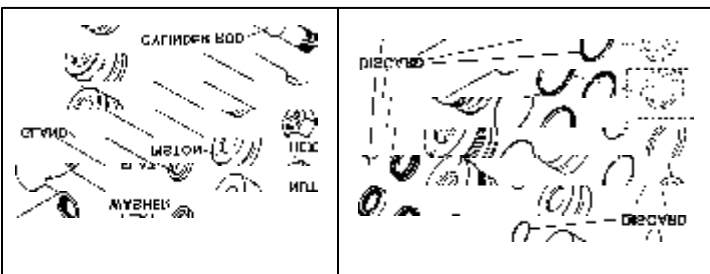

ASSEMBLY PROCEDURE

IMPORTANT: Replace all seals even if they do not appear to be damaged. Failure to replace all seals may result in premature cylinder failure.

1. Install the cylinder rod seal in the gland first. Be careful not to damage the seal in the process as it is somewhat difficult to install.

A special installation tool (Part #65349) is available to help with installing the seal. Simply fit the end of the tool over the seal so that the large prong of the tool is on the outside of the seal, and the two smaller prongs on the inside. The lip of the seal should be facing towards the tool.

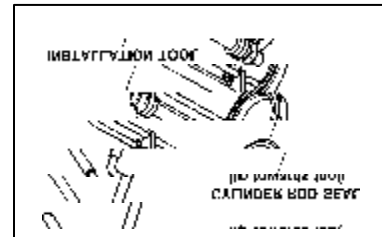

Rotate the handles on the tool around to wrap the seal around the end of the tool.

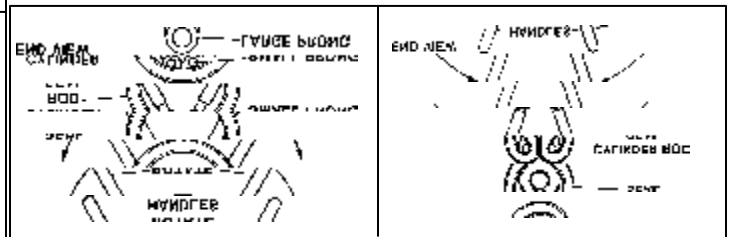

Now insert the seal into the gland from the inner end. Position the seal in its groove, and release and remove the tool. Press the seal into its seat the rest of the way by hand.

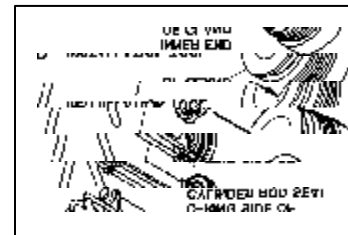

2. Install the new piston ring, rod wiper, O-rings and backup washers if applicable on the piston.

Be careful not to damage the seals. Caution must be used when installing the piston ring. The ring must be stretched carefully over the piston with a smooth, round, pointed tool.

MAINTENANCE

CYLINDER SEAL REPLACEMENT

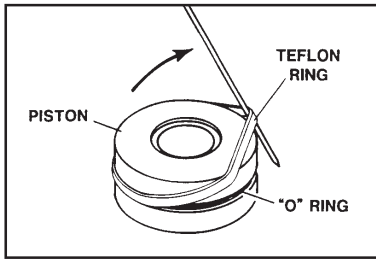

3. After installing the rod seal inside the gland as shown in step #1, install the external seal.

NOTE: Threaded glands may have been equipped with a separate O-ring and backup washer system or a polypak (all in one) type seal. Current seal kits contain a polypak (all in one) type seal to replace the discarded seal types on ALL THREADED GLANDS.

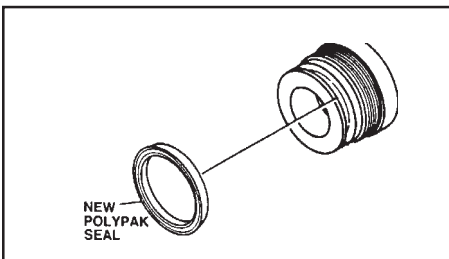

4. Slide the gland onto the cylinder rod being careful not to damage the rod wiper. Then install the spacer, or flat washer (if so equipped), small o-ring, piston, and hex nut onto the end of the cylinder rod.

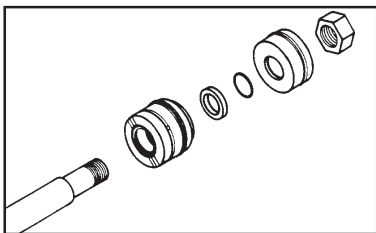

5. Secure the cylinder rod (mounting end) in a vise with a support at it's center. Torque the nut to the amount shown for the thread diameter of the cylinder rod (see chart).

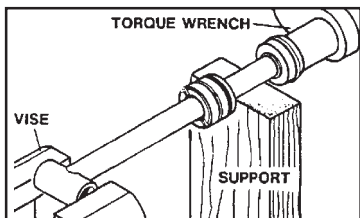

IMPORTANT: Do not contact the active surface of the cylinder rod with the vise. Damage to the rod could result.

6. Apply a lubricant (such as Lubriplate #105) to the piston and teflon ring. Insert the cylinder rod assembly into the cylinder tube.

IMPORTANT: Ensure that the piston ring fits squarely into the cylinder tube and piston groove, otherwise the ring may be damaged and a leak will occur.

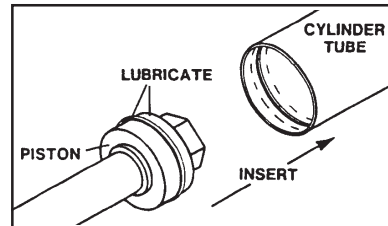

7. Use a spanner wrench to rotate the gland clockwise into the cylinder. Continue to rotate the gland with the spanner wrench until it is tight.

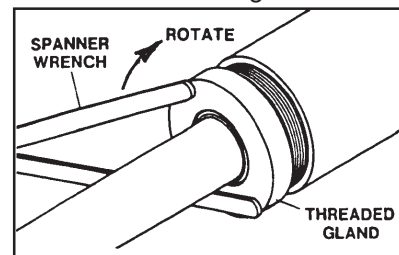

NOTE: Seal kits will service most cylinders of similar bore size and rod diameter.

WARNING!



Cylinders serviced in the field are to be tested for leakage prior to the attachment being placed in work. Failure to test rebuilt cylinders could result in damage to the cylinder and/or the attachment, cause severe personal injury or even death.

TORQUE SPECIFICATION CHART

Use the following torque values when tightening the nuts on the cylinder rod threads.

Thread Diameter	POUNDS - FEET	
	Minimum	Maximum
7/8"	150	200
* 1"	230	325
1-1/8"	350	480
1-1/4"	490	670
1-3/8"	670	900

* 1" Thread Diameter WITH 1.25" Rod Diameter
 Min. 230 ft. lbs. Max. 250 ft. lbs.

STORAGE & TRANSPORTING

GENERAL INFORMATION

The following storage procedure will help you to keep your attachment in top condition. It will also help you get off to a good start the next time your tree spade is needed. We therefore, strongly recommend that you take the extra time to follow these procedures whenever your attachment will not be used for an extended period of time.

PREPARATION FOR STORAGE

1. Clean the exterior thoroughly removing all mud, dirt and grease.
2. Inspect the unit for visible signs of wear. Order any parts required and make any necessary repairs to avoid delays when starting next season.
3. Inspect the graphite coating on the blades. Repaint as needed.
4. Check the blades for wear. If sharpening is required use a hand grinder.
5. Tighten all loose nuts and capscrews.
6. Grease all grease fittings. (See Section H)
7. Coat the exposed portions of the cylinder rods with grease.
8. Connect the hydraulic couplers together to protect the hydraulic system from contaminants. (Cap the fittings for the rear stabilizers if couplers not used.)
9. Replace decals if damaged or in unreadable condition.
10. Store the unit in a dry and protected place. Leaving the unit outside will materially shorten its life.

REMOVING FROM STORAGE

1. Remove all protective coverings.
2. Check hydraulic hoses for deterioration and replace if necessary.

TRANSPORTING

1. Follow all federal, state and local regulations when transporting the unit on public roads.
2. Use extra care when loading or unloading the machine onto a trailer or truck.
3. Before transporting, raise the blades and keep the unit as close to the ground as possible.

CAUTION! Be sure to install a SMV (Slow Moving Vehicle) sign on the loader before attempting to transport.



When transporting on a road or highway at night or during the day, use accessory lights and devices for adequate warning to the operators of other vehicles. In this regard, check local government regulations.

Always drive slowly over uneven terrain to avoid tipping the unit.

TROUBLESHOOTING

<u>PROBLEM</u>	<u>POSSIBLE CAUSE</u>	<u>POSSIBLE REMEDY</u>
Tree Spade will not operate.	Auxiliary hoses not hooked up to the skid-steer.	Engage Couplers
	Obstruction in hydraulic lines.	Remove obstruction and replace if necessary.
	Skid-steer auxiliary valve not engaged.	Engage auxiliary valve.
	Loss of electrical power to joystick control.	Check electrical connection and circuit fuse.
Blades activate sluggishly.	Insufficient hydraulic flow from the skid-steer.	Refer to skid-steer's owners manual.
	Damaged quick coupler.	Replace if necessary.
	Oil filter on skid-steer is dirty.	Refer to skid-steer's owners manual.
Leaking Oil.	Loose or damaged hydraulic line.	Tighten or replace.
	O-Rings on fittings damaged.	Replace if necessary.
	Fittings loose or damaged.	Tighten or replace.
	Cylinder seals damaged.	Replace cylinder seals.
Insufficient power.	Insufficient hydraulic flow from the skid-steer.	Refer to skid-steer's owners manual.
	Relief valve setting adjusted too low.	Refer to skid-steer's owners manual.
	Oil filter on skid-steer is dirty.	Refer to skid-steer's owners manual.
	Blades or Undercutter worn or chipped.	Sharpen as needed.
Cylinders operate in the wrong direction.	Hoses from the valve to the skid-steer incorrectly connected.	Switch couplers at the skid steer end.
	Incorrect wiring from the joystick control.	Check wiring diagram and correct.

TROUBLESHOOTING

<u>PROBLEM</u>	<u>POSSIBLE CAUSE</u>	<u>POSSIBLE REMEDY</u>
Excessive oil temperature.	Hydraulic oil level too low.	Refer to skid-steer's owners manual
	Obstruction in hydraulic lines.	Remove obstruction and replace if necessary.
	Hydraulic oil or oil filter in skid-steer is dirty.	Refer to skid-steer's owners manual.
	Relief valve setting adjusted too low.	Refer to skid-steer's owners manual.
	Couplers not engaged.	Engage couplers.
A hydraulic cylinder not operating.	Insufficient hydraulic flow from the skid-steer.	Refer to skid-steer's owners manual.
	Cylinder rod bent.	Visually inspect the cylinder for damage.
	Cylinder seals damaged.	Replace cylinder seals.
	Obstruction in hydraulic lines.	Remove obstruction and replace if necessary.
	An electrical coil not functioning at valve.	Check voltage readings at valve and replace coil if necessary.
All hydraulic cylinders not functioning.	Blown fuse on skid-steer.	Refer to skid-steer's owners manual.
	Damaged electrical wiring.	Test and replace if necessary.
	Loss of hydraulic power.	Check hydraulic circuit.
	Electrical power connected to wrong polarity.	Reverse red and black wires.
Hydraulic cylinders only operating in one direction.	Contaminants in the hydraulic system and solenoid valve.	Remove spool from solenoid valve and check for foreign material. Clean or replace. Remove spool from solenoid valve and check seals for damage. Replace if necessary.
	Damaged electrical wiring.	Test and replace if necessary.
	Bad electrical connection at Reversing valve.	Check connections and correct.
	Coil or spool damaged in reversing valve.	Replace as necessary.



BOLT TORQUE

BOLT TORQUE SPECIFICATIONS

GENERAL TORQUE SPECIFICATION TABLE

Use the following torques when special torques are not given. These values apply to fasteners as received from suppliers, dry, or when lubricated with normal engine oil. They do not apply if special graphited or moly disulphide greases or other extreme pressure lubricants are used. This applies to both UNF and UNC threads. Remember to always use grade five or better when replacing bolts.

SAE Grade No.		2				5				8*			
Bolt head identification marks as per grade. NOTE: Manufacturing Marks Will Vary													
		TORQUE		TORQUE		TORQUE		TORQUE		TORQUE		TORQUE	
Bolt Size		Pounds Feet		Newton-Meters		Pounds Feet		Newton-Meters		Pounds Feet		Newton-Meters	
Inches	Millimeters	Min.	Max.	Min.	Max.	Min.	Max.	Min.	Max.	Min.	Max.	Min.	Max.
1/4	6.35	5	6	6.8	8.13	9	11	12.2	14.9	12	15	16.3	30.3
5/16	7.94	10	12	13.6	16.3	17	20.5	23.1	27.8	24	29	32.5	39.3
3/8	9.53	20	23	27.1	31.2	35	42	47.5	57.0	45	54	61.0	73.2
7/16	11.11	30	25	40.7	47.4	54	64	73.2	86.8	70	84	94.9	113.9
1/2	12.70	45	52	61.0	70.5	80	96	108.5	130.2	110	132	149.2	179.0
9/16	14.29	65	75	88.1	101.6	110	132	149.2	179.0	160	192	217.0	260.4
5/8	15.88	95	105	128.7	142.3	150	180	203.4	244.1	220	264	298.3	358.0
3/4	19.05	150	185	203.3	250.7	270	324	366.1	439.3	380	456	515.3	618.3
7/8	22.23	160	200	216.8	271.0	400	480	542.4	650.9	600	720	813.6	976.3
1	25.40	250	300	338.8	406.5	580	696	786.5	943.8	900	1080	1220.4	1464.5
1-1/8	25.58	-	-	-	-	800	880	1084.8	1193.3	1280	1440	1735.7	1952.6
1-1/4	31.75	-	-	-	-	1120	1240	1518.7	1681.4	1820	2000	2467.9	2712.0
1-3/8	34.93	-	-	-	-	1460	1680	1979.8	2278.1	2380	2720	3227.3	3688.3
1-1/2	38.10	-	-	-	-	1940	2200	2630.6	2983.2	3160	3560	4285.0	4827.4

* Thick Nuts must be used with Grade 8 bolts

METRIC BOLT TORQUE SPECIFICATIONS

Size of Screw	Grade No.	Coarse Thread			Fine Thread		
		Ptich (mm)	Pounds Feet	Newton-Meters	Pitch (mm)	Pounds Feet	Newton-Meters
M6	5.6	1.0	3.6-5.8	4.9-7.9	-	-	-
	8.8		5.8-9.4	7.9-12.7		-	-
	10.9		7.2-10	9.8-13.6		-	-
M8	5.6	1.25	7.2-14	9.8-19	1.0	12-17	16.3-23
	8.8		17-22	23-29.8		19-27	25.7-36.6
	10.9		20-26	27.1-35.2		22-31	29.8-42
M10	5.6	1.5	20-25	27.1-33.9	1.25	20-29	27.1-39.3
	8.8		34-40	46.1-54.2		35-47	47.4-63.7
	10.9		38-46	51.5-62.3		40-52	54.2-70.5
M12	5.6	1.75	28-34	37.9-46.1	1.25	31-41	42-55.6
	8.8		51-59	69.1-79.9		56-68	75.9-92.1
	10.9		57-66	77.2-89.4		62-75	84-101.6
M14	5.6	2.0	49-56	66.4-75.9	1.5	52-64	70.5-86.7
	8.8		81-93	109.8-126		90-106	122-143.6
	10.9		96-109	130.1-147.7		107-124	145-168
M16	5.6	2.0	67-77	90.8-104.3	1.5	69-83	93.5-112.5
	8.8		116-130	157.2-176.2		120-138	162.6-187
	10.9		129-145	174.8-196.5		140-158	189.7-214.1
M18	5.6	2.0	88-100	119.2-136	1.5	100-117	136-158.5
	8.8		150-168	203.3-227.6		177-199	239.8-269.6
	10.9		175-194	237.1-262.9		202-231	273.7-313
M20	5.6	2.5	108-130	146.3-176.2	1.5	132-150	178.9-203.3
	8.8		186-205	252-277.8		206-242	279.1-327.9
	10.9		213-249	288.6-337.4		246-289	333.3-391.6

SPECIFICATIONS

2415 & 3215 TREE SPADES

SPECIFICATION AND DESIGN ARE SUBJECT TO CHANGE WITHOUT NOTICE AND WITHOUT LIABILITY THEREFORE.

** SPECIFICATIONS ARE BASED ON A MODEL 3215 WITH 32" BLADE SET AND A MODEL 2415 WITH 24" BLADE SET.

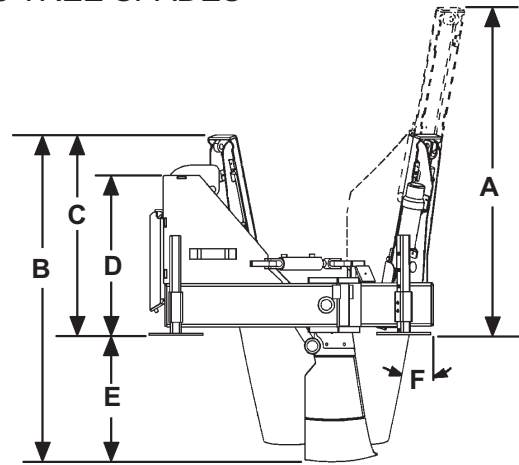

2415

3215

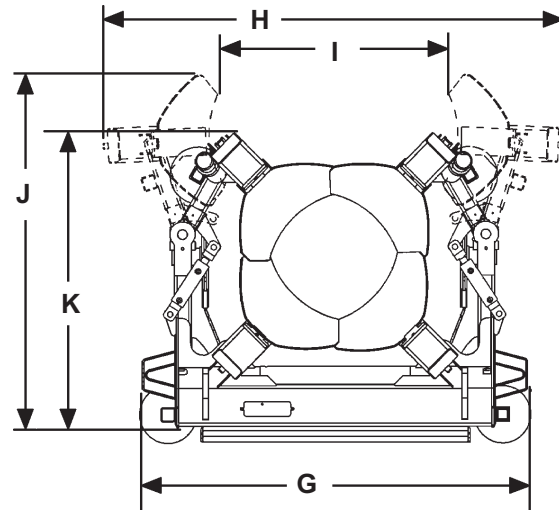
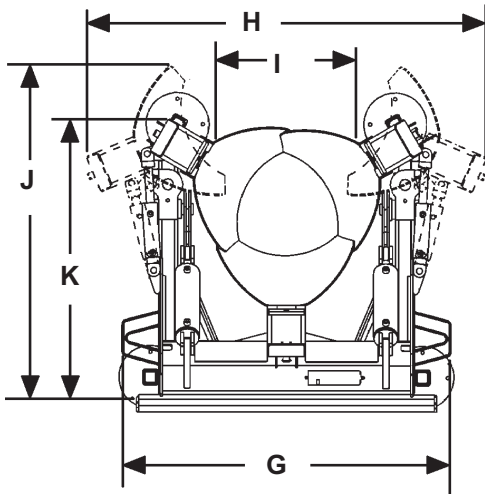

DESCRIPTION	2415	3215
A. Overall Height - Blades Up (Open)	52.00"	60.00"
B. Overall Height - Blades Down (Closed)	51.75"	61.00"
C. Shipping Height - (Blades Removed)	33.00"	37.00"
D. Frame Height	29.50"	29.50"
E. Digging Depth	20.00"	24.00"
F. Cutting Angle	15°	15°
G. Overall Transport Width (Gate Closed)	52.00"	68.00"
H. Overall Width (Gate Open)	63.00"	81.00"
I. Maximum Gate Opening	21.50"	41.00"
J. Overall Length (Gate Open)	52.00"	61.50"
K. Overall Transport Length (Gate Closed)	47.50"	51.50"
Number of Blades	3	4
Blade Sizes Available (Ball Diameter)	16"-20"-24"	20"-24"-28"-32"
Tree Diameter	1.50"-2.50"	2.00"-3.5"
Ball Weight (LBS)	200#-400#	300#-900#
Flow Requirements (GPM)	10	10
Recommended Operating Pressure (PSI)	2250	2250
Weight (LBS)	1200#	1600#

DECALS

DECAL PLACEMENT

GENERAL INFORMATION

The diagram on this page shows the location of the decals used on the BRADCO Tree Spades. The decals are identified by their part numbers, with reductions of the actual decals located on the following pages. Use this information to order replacements for lost or damaged decals. Be sure to read all decals before operating the tree spade. They contain information you need to know for both safety and attachment longevity.

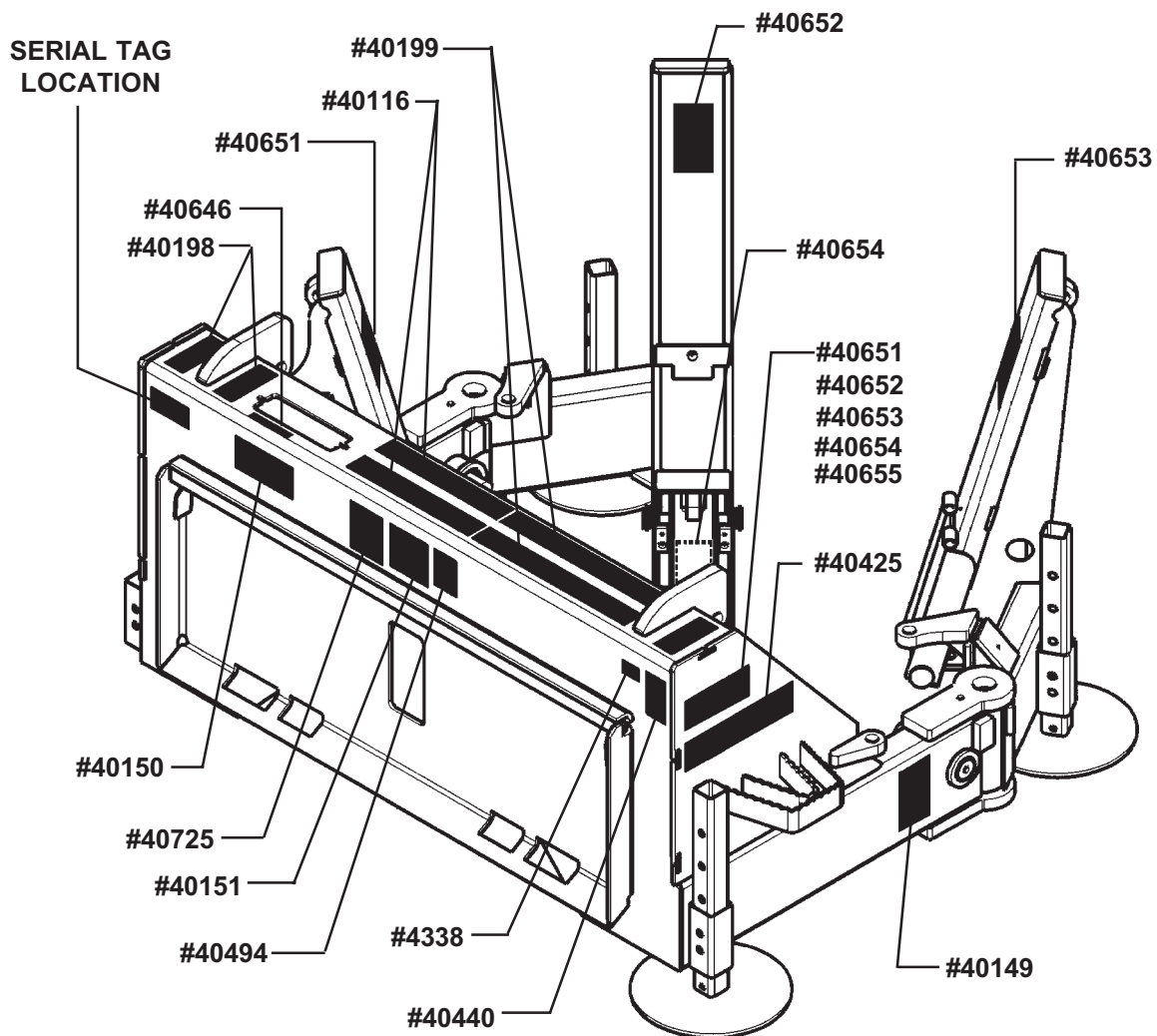

IMPORTANT: Keep all safety signs clean and legible. Replace all missing, illegible or damaged safety signs. When replacing parts with safety signs attached, the safety signs must also be replaced.

REPLACING SAFETY DECALS: Clean the area of application with a nonflammable solvent, then wash the same area with soap and water. Allow the surface to dry. Remove the backing from the safety sign, exposing the adhesive surface. Apply the safety sign to the position shown in the diagram above and smooth out any bubbles.

DECALS

USE NUMBER DECALS FOR BLADE NUMBER AND IN MODEL NUMBER (IF REQUIRED)

1

NUMBER "1"
PART #40651

2

NUMBER "2"
PART #40652

3

NUMBER "3"
PART #40653

4

NUMBER "4"
PART #40654

5

NUMBER "5"
PART #40655

REAR STABILIZER
#40646

REAR STABILIZER
PART #40646



MADE IN U.S.A.
PART #4338

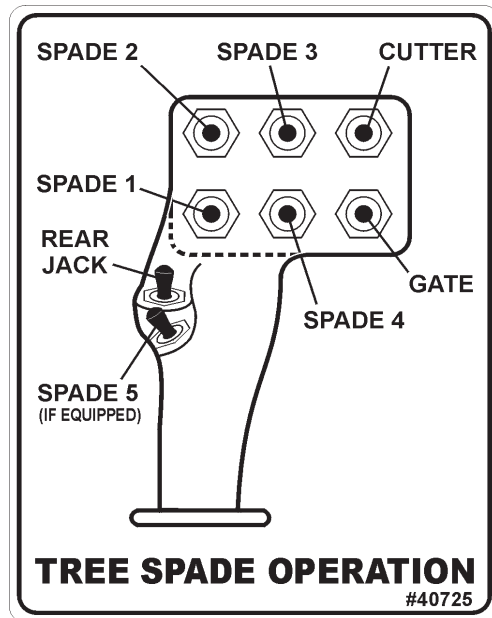

OPERATION DECAL
PART #40725



NON-SLIP SURFACE 2X6
PART #40198

NON-SLIP SURFACE 2X13
PART #40116

NON-SLIP SURFACE 2X15
PART #40199

BRADCO®

BRADCO
PART #40425



DANGER! PINCH POINT
PART #40149



WARNING! HIGH PRESSURE FLUID
PART #40151

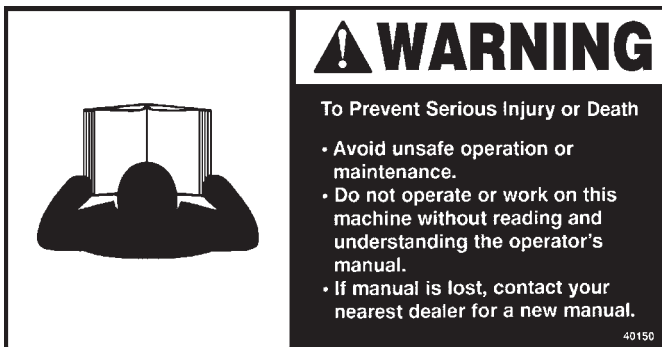

WARNING! READ MANUAL
PART #40150



CALL BEFORE YOU DIG
PART #40440

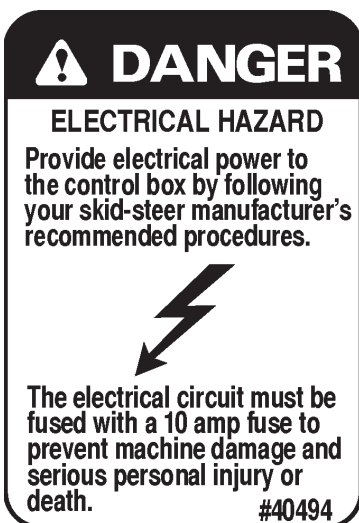

DANGER! ELECTRICAL HAZARD
PART #40494

PREDELIVERY CHECKLIST

GENERAL INFORMATION

The following is a list of areas that should be inspected by the dealer prior to delivery of the attachment to the customer. The customer should check the list and make sure that the dealer has completed the inspection. Completion of this checklist will help insure that the customer receives the attachment in complete working order, ready to install.

PREDELIVERY CHECKLIST - CHECK AND ADJUST AS NECESSARY

1. _____ Visually inspect the attachment for bent, cracked, damaged or missing parts. Check for any other irregularities.
2. _____ Check and lubricate attachment if necessary. See "Lubrication" Section H.
3. _____ Check bolts for tightness daily. Retighten after the first eight working hours.
4. _____ Remove paint from unfinished chrome surfaces of cylinders.
5. _____ Run cylinders through their full cycle to purge any air from the system.
6. _____ Check all hydraulic connections for leaks and hoses for proper positioning to reduce chafing and binding.
7. _____ Make sure all decals are not damaged or missing and are in their correct location. See "Decals" Section Q.
8. _____ Make sure customer has the necessary couplers to attach the power and return hoses to the skid-steer auxiliary hydraulic couplers.
9. _____ Complete and return the manufacturers "Warranty Validation Form" and sign your dealership predelivery checklist.

LIMITED WARRANTY

EFFECTIVE ON PRODUCTS MANUFACTURED AFTER JANUARY 1, 2001

All new BRADCO products are warranted to be free from defects in materials or workmanship which may cause failure under normal usage and service when used for the purpose intended.

In the event of failure within twenty four (24) months from initial retail sale, lease or rental date (excluding cable, ground engaging parts such as sprockets, digging chain, bearings, teeth, tamping and demolition heads, blade cutting edges, pilot bits, auger teeth, auger heads & broom bristles), if after examination, BRADCO determines failure was due to defective material and/or workmanship, parts will be repaired or replaced. BRADCO may request defective part or parts be returned prepaid to them for inspection at their place of business at Delhi, Iowa, or to a location specified by BRADCO.

Any claims under this warranty must be made within fifteen (15) days after the Buyer learns of the facts upon which such claim is based. All claims not made in writing and received by BRADCO within the time period specified above shall be deemed waived.

THIS WARRANTY IS IN LIEU OF ALL OTHER WARRANTIES EXPRESSED OR IMPLIED AND THERE ARE NO WARRANTIES OF MERCHANTABILITY OR OF FITNESS FOR A PARTICULAR PURPOSE. IN NO EVENT SHALL BRADCO BE LIABLE FOR CONSEQUENTIAL OR SPECIAL DAMAGE.

BRADCO'S LIABILITY FOR ANY AND ALL LOSSES AND DAMAGES TO BUYER, RESULTING FROM ANY CAUSE WHATSOEVER, INCLUDING BRADCO'S NEGLIGENCE, IRRESPECTIVE OF WHETHER SUCH DEFECTS ARE DISCOVERABLE OR LATENT, SHALL IN NO EVENT EXCEED THE PURCHASE PRICE OF THE PARTICULAR PRODUCTS WITH RESPECT TO WHICH LOSSES OR DAMAGES ARE CLAIMED, OR, AT THE ELECTION OF BRADCO, THE REPAIR OR REPLACEMENT OF DEFECTIVE OR DAMAGED PRODUCTS.