



2030 TREE SPADE OPERATOR'S & PARTS MANUAL



PALADIN LIGHT CONSTRUCTION

ALL APPLICATIONS



SERIAL NUMBER: _____

MODEL NUMBER: _____

Manual Number: OM684
Part Number: 75584
Rev.

TABLE OF CONTENTS

PREFACE	3
SAFETY PRECAUTIONS	
SAFETY STATEMENTS	5
GENERAL SAFETY PRECAUTIONS	5-7
EQUIPMENT SAFETY PRECAUTIONS	8
DECALS	
DECAL PLACEMENT	9
DECALS	10-11
PRE-OPERATION	13
INSTALLATION	14-15
OPERATING INSTRUCTIONS	
CONTROLS	16-17
BALL SIZE GUIDELINES	17-18
ADJUSTING LEG HEIGHT	19
BALLED AND BURLAPPED TREES	19-20
DIRECT TRANSPLANTING	20
STORAGE & TRANSPORTING	21
MAINTENANCE AND SERVICE	
GENERAL MAINTENANCE	22
LUBRICATION	23
BLADE MAINTENANCE AND SHARPENING	23
REPLACING BUSHINGS	23
BLADE ADJUSTMENT & WEAR PLATE REPLACEMENT	24
CYLINDER SEAL REPLACEMENT	25-26
TROUBLESHOOTING	27-28
SPECIFICATIONS	
BOLT TORQUE SPECIFICATIONS	29
TREE SPADE SPECIFICATIONS	30
LIMITED WARRANTY	31
PARTS	
2030 TREE SPADE ASSEMBLY	32-35
MOUNTING KITS	36-37
POWER AND RETURN HYDRAULIC CIRCUIT	38-39
BLADE HYDRAULIC CIRCUIT	40-41
GATE HYDRAULIC CIRCUIT	42-43
GATE CYLINDER ASSEMBLY	44-45
BLADE CYLINDER ASSEMBLY	46-47
ELECTRICAL VALVE ASSEMBLY	48-49
VALVE ASSEMBLY	50-51
SOLENOID VALVE REPLACEMENT PARTS	52-53
JOYSTICK AND WIRE HARNESS ASSEMBLY	54-55
WIRING SCHEMATIC FOR DEUTSCH CONNECTORS	56

PREFACE

GENERAL COMMENTS

Congratulations on the purchase of your new BRADCO product! This product was carefully designed and manufactured to give you many years of dependable service. Only minor maintenance (such as cleaning and lubricating) is required to keep it in top working condition. Be sure to observe all maintenance procedures and safety precautions in this manual and on any safety decals located on the product and on any equipment on which the attachment is mounted.

This manual has been designed to help you do a better, safer job. Read this manual carefully and become familiar with its contents.

WARNING!  Never let anyone operate this unit without reading the "Safety Precautions" and "Operating Instructions" sections of this manual. Always choose hard, level ground to park the vehicle on and set the brake so the unit cannot roll.

Unless noted otherwise, right and left sides are determined from the operator's control position when facing the attachment.

NOTE: The illustrations and data used in this manual were current (according to the information available to us) at the time of printing, however, we reserve the right to redesign and change the attachment as may be necessary without notification.

BEFORE OPERATION

The primary responsibility for safety with this equipment falls to the operator. Make sure the equipment is operated only by trained individuals that have read and understand this manual. If there is any portion of this manual or function you do not understand, contact your local authorized dealer or the manufacturer.

SAFETY ALERT SYMBOL



This is the "Safety Alert Symbol" used by this industry. This symbol is used to warn of possible injury. Be sure to read all warnings carefully. They are included for your safety and for the safety of others working with you.

SERVICE

When servicing your product, remember to use only manufacturer replacement parts. Substitute parts may not meet the standards required for safe, dependable operation.

To facilitate parts ordering, record the model and serial number of your unit in the space provided on the cover of this manual. This information may be obtained from the identification plate located on the product.

The parts department needs this information to insure that you receive the correct parts for your specific model.

SAFETY STATEMENTS



THIS SYMBOL BY ITSELF OR WITH A WARNING WORD THROUGHOUT THIS MANUAL IS USED TO CALL YOUR ATTENTION TO INSTRUCTIONS INVOLVING YOUR PERSONAL SAFETY OR THE SAFETY OF OTHERS. FAILURE TO FOLLOW THESE INSTRUCTIONS CAN RESULT IN INJURY OR DEATH.



DANGER

THIS SIGNAL WORD IS USED WHERE SERIOUS INJURY OR DEATH WILL RESULT IF THE INSTRUCTIONS ARE NOT FOLLOWED PROPERLY.



WARNING

THIS SIGNAL WORD IS USED WHERE SERIOUS INJURY OR DEATH COULD RESULT IF THE INSTRUCTIONS ARE NOT FOLLOWED PROPERLY.



CAUTION

THIS SIGNAL WORD IS USED WHERE MINOR INJURY COULD RESULT IF THE INSTRUCTIONS ARE NOT FOLLOWED PROPERLY.

NOTICE

NOTICE INDICATES A PROPERTY DAMAGE MESSAGE.

GENERAL SAFETY PRECAUTIONS

WARNING!

READ MANUAL PRIOR TO INSTALLATION



Improper installation, operation, or maintenance of this equipment could result in serious injury or death. Operators and maintenance personnel should read this manual, as well as all manuals related to this equipment and the prime mover thoroughly before beginning installation, operation, or maintenance. **FOLLOW ALL SAFETY INSTRUCTIONS IN THIS MANUAL AND THE PRIME MOVER'S MANUAL(S).**



READ AND UNDERSTAND ALL SAFETY STATEMENTS

Read all safety decals and safety statements in all manuals prior to operating or working on this equipment. Know and obey all OSHA regulations, local laws, and other professional guidelines for your operation. Know and follow good work practices when assembling, maintaining, repairing, mounting, removing, or operating this equipment.



KNOW YOUR EQUIPMENT

Know your equipment's capabilities, dimensions, and operations before operating. Visually inspect your equipment before you start, and never operate equipment that is not in proper working order with all safety devices intact. Check all hardware to ensure it is tight. Make certain that all locking pins, latches, and connection devices are properly installed and secured. Remove and replace any damaged, fatigued, or excessively worn parts. Make certain all safety decals are in place and are legible. Keep decals clean, and replace them if they become worn or hard to read.

GENERAL SAFETY PRECAUTIONS

WARNING!



PROTECT AGAINST FLYING DEBRIS

Always wear proper safety glasses, goggles, or a face shield when driving pins in or out, or when any operation causes dust, flying debris, or any other hazardous material.

WARNING!



LOWER OR SUPPORT RAISED EQUIPMENT

Do not work under raised booms without supporting them. Do not use support material made of concrete blocks, logs, buckets, barrels, or any other material that could suddenly collapse or shift positions. Make sure support material is solid, not decayed, warped, twisted, or tapered. Lower booms to ground level or on blocks. Lower booms and attachments to the ground before leaving the cab or operator's station.

WARNING!



USE CARE WITH HYDRAULIC FLUID PRESSURE

Hydraulic fluid under pressure can penetrate the skin and cause serious injury or death. Hydraulic leaks under pressure may not be visible. Before connecting or disconnecting hydraulic hoses, read your prime mover's operator's manual for detailed instructions on connecting and disconnecting hydraulic hoses or fittings.

- Keep unprotected body parts, such as face, eyes, and arms as far away as possible from a suspected leak. Flesh injected with hydraulic fluid may develop gangrene or other permanent disabilities.
- If injured by injected fluid, see a doctor at once. If your doctor is not familiar with this type of injury, ask him to research it immediately to determine proper treatment.
- Wear safety glasses, protective clothing, and use a piece of cardboard or wood when searching for hydraulic leaks. **DO NOT USE YOUR HANDS!** **SEE ILLUSTRATION.**

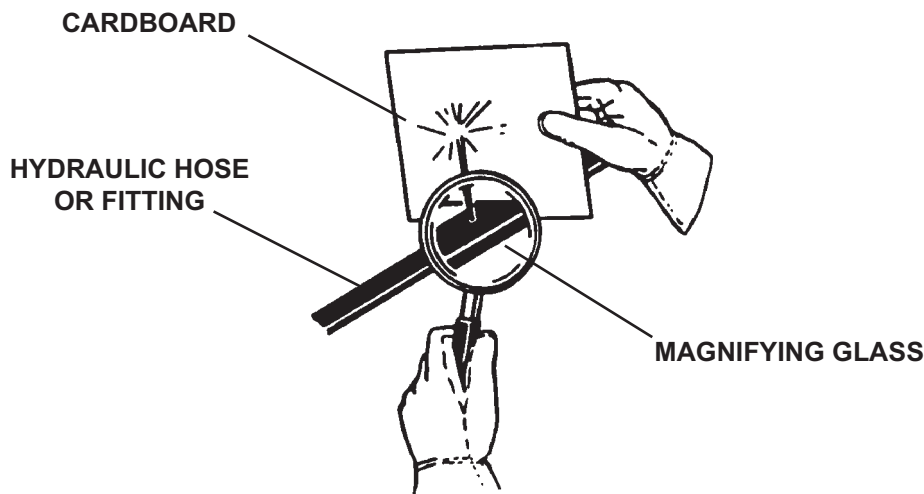

GENERAL SAFETY PRECAUTIONS

WARNING!



DO NOT MODIFY MACHINE OR ATTACHMENTS

Modifications may weaken the integrity of the attachment and may impair the function, safety, life, and performance of the attachment. When making repairs, use only the manufacturer's genuine parts, following authorized instructions. Other parts may be substandard in fit and quality. Never modify any ROPS (Roll Over Protection Structure) or FOPS (Falling Object Protective Structure) equipment or device. Any modifications must be authorized in writing by the manufacturer.

WARNING!



SAFELY MAINTAIN AND REPAIR EQUIPMENT

- Do not wear loose clothing or any accessories that can catch in moving parts. If you have long hair, cover or secure it so that it does not become entangled in the equipment.
- Work on a level surface in a well-lit area.
- Use properly grounded electrical outlets and tools.
- Use the correct tools for the job at hand. Make sure they are in good condition for the task required.
- Wear the protective equipment specified by the tool manufacturer.



SAFELY OPERATE EQUIPMENT

Do not operate equipment until you are completely trained by a qualified operator in how to use the controls, know its capabilities, dimensions, and all safety requirements. See your machine's manual for these instructions.

- Keep all step plates, grab bars, pedals, and controls free of dirt, grease, debris, and oil.
- Never allow anyone to be around the equipment when it is operating.
- Do not allow riders on the attachment or the prime mover.
- Do not operate the equipment from anywhere other than the correct operator's position.
- Never leave equipment unattended with the engine running, or with this attachment in a raised position.
- Do not alter or remove any safety feature from the prime mover or this attachment.
- Know your work site safety rules as well as traffic rules and flow. When in doubt on any safety issue, contact your supervisor or safety coordinator for an explanation.

EQUIPMENT SAFETY PRECAUTIONS

WARNING!



KNOW WHERE UTILITIES ARE

Observe overhead electrical and other utility lines. Be sure equipment will clear them. When digging, call your local utilities for location of buried utility lines, gas, water, and sewer, as well as any other hazard you may encounter.



OPERATING THE TREE SPADE

- Block off work area from bystanders, livestock, etc.
- Operate only from the operator's station.
- Do not lift loads in excess of the capacity of the prime mover.
- When operating on slopes, drive up and down, not across. Avoid steep hillside operation, which could cause the prime mover to overturn.
- Reduce speed when driving over rough terrain, on a slope, or turning, to avoid overturning the vehicle.
- An operator must not use drugs or alcohol, which can change his or her alertness or coordination. An operator taking prescription or over-the-counter drugs should seek medical advice on whether or not he or she can safely operate equipment.
- Before exiting the prime mover, lower the attachment to the ground, turn off the prime mover's engine, remove the key and apply the brakes.

TRANSPORTING THE TREE SPADE



- Travel only with the attachment in a safe transport position to prevent uncontrolled movement. Drive slowly over rough ground and on slopes.
- When driving on public roads use safety lights, reflectors, Slow Moving Vehicle signs etc., to prevent accidents. Check local government regulations that may affect you.
- Do not drive close to ditches, excavations, etc., cave in could result.
- Do not smoke when refueling the prime mover. Allow room in the gas tank for expansion. Wipe up any spilled fuel. Secure cap tightly when done.

MAINTAINING THE TREE SPADE



- Before performing maintenance, lower the attachment to the ground, turn off the engine, remove the key and apply the brakes.
- Never perform any work on the attachment unless you are authorized and qualified to do so. Always read the operator service manual's before any repair is made. After completing maintenance or repair, check for correct functioning of the attachment. If not functioning properly, always tag "DO NOT OPERATE" until all problems are corrected.
- Worn, damaged, or illegible safety decals must be replaced. New safety decals can be ordered from BRADCO.
- Never make hydraulic repairs while the system is under pressure. Serious personal injury or death could result.
- Never work under a raised attachment.

DECALS

DECAL PLACEMENT

GENERAL INFORMATION

The diagram on this page shows the location of the decals used on the BRADCO 2030 Tree Spade. The decals are identified by their part numbers, with reductions of the actual decals located on the following pages. Use this information to order replacements for lost or damaged decals. Be sure to read all decals before operating the tree spade. They contain information you need to know for both safety and attachment longevity.

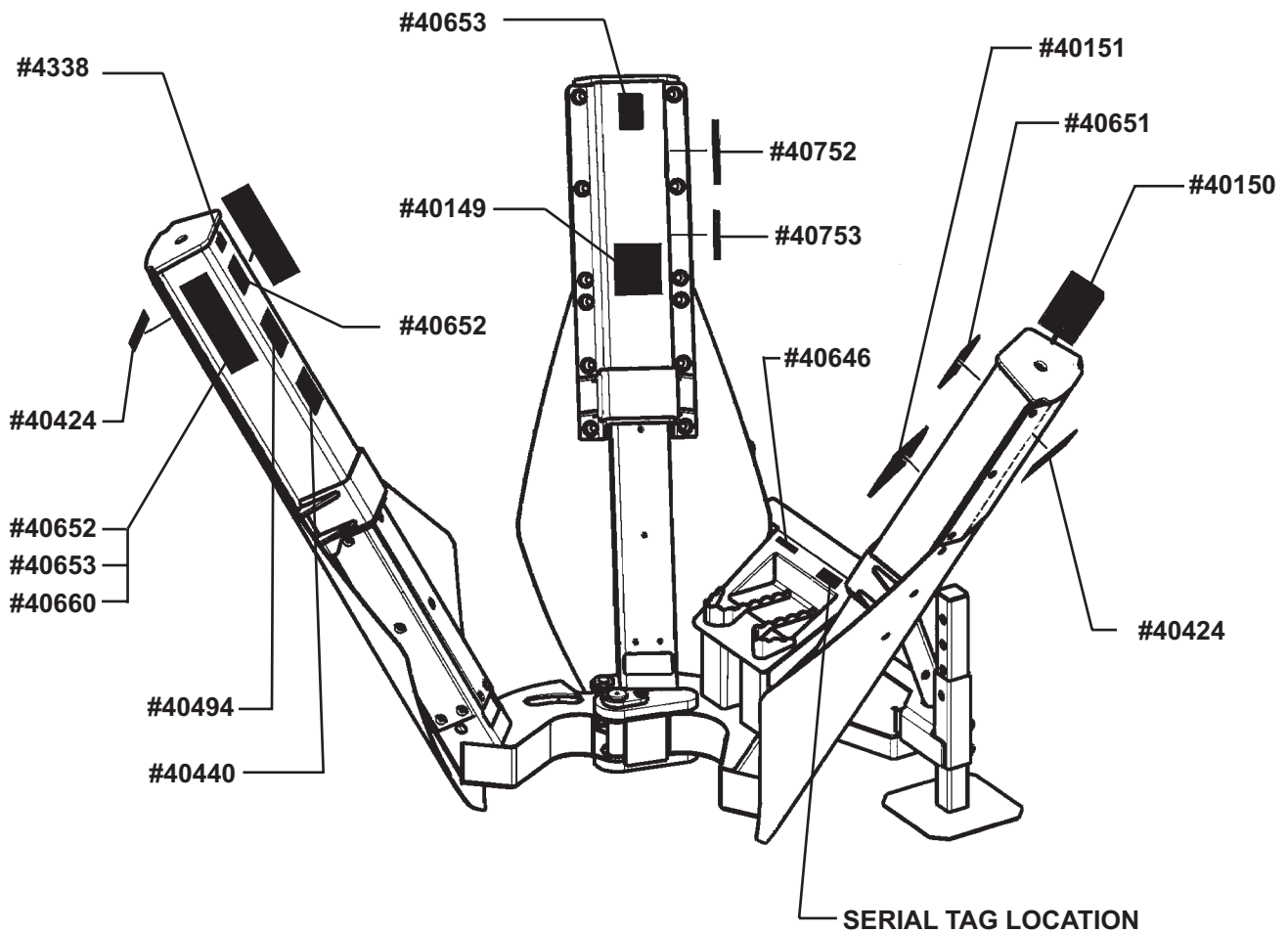

IMPORTANT: Keep all safety signs clean and legible. Replace all missing, illegible or damaged safety signs. When replacing parts with safety signs attached, the safety signs must also be replaced.

REPLACING SAFETY DECALS: Clean the area of application with a nonflammable solvent, then wash the same area with soap and water. Allow the surface to dry. Remove the backing from the safety sign, exposing the adhesive surface. Apply the safety sign to the position shown in the diagram above and smooth out any bubbles.

10504 2-28-06

DECALS

1

NUMBER "1"
PART #40651

2

NUMBER "2"
PART #40652

3

NUMBER "3"
PART #40653

0

NUMBER "0"
PART #40660



MADE IN USA
PART #4338

REAR STABILIZER

#40646

REAR STABILIZER
PART #40646



BRADCO

BRADCO LOGO
PART #40424

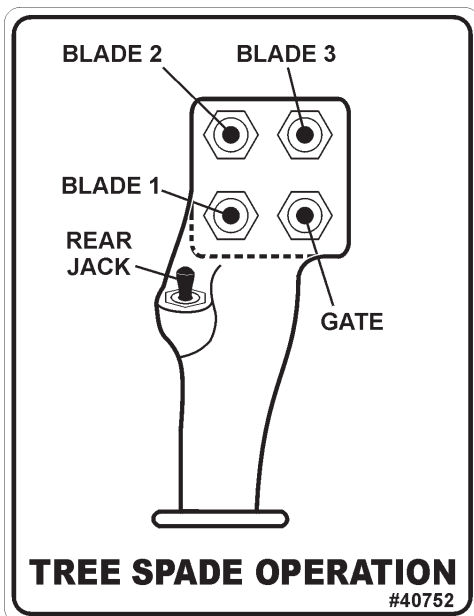

OPERATION DECAL
PART #40752



CAUTION! CYLINDER DAMAGE
PART #40753

DECALS



**DANGER! PINCH POINT
PART #40149**



**WARNING! HIGH PRESSURE FLUID
PART #40151**

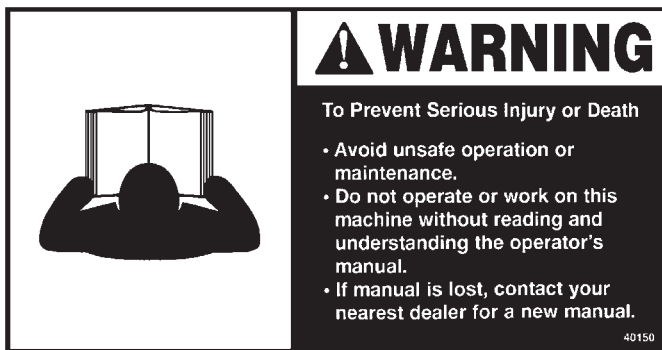

**WARNING! READ MANUAL
PART #40150**

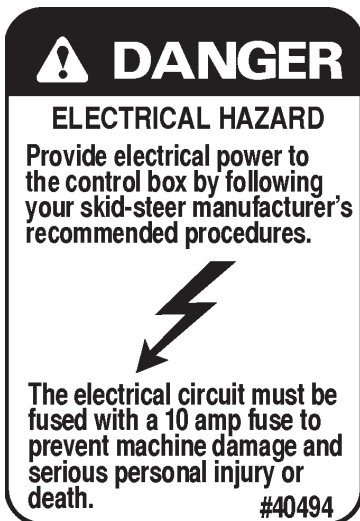

**DANGER! ELECTRICAL HAZARD
PART #40494**



**CALL BEFORE YOU DIG
PART #40440**

PRE-OPERATION

GENERAL INFORMATION

The BRADCO tree spades were designed to be easy to use and maintain. They are powered by the skid-steers auxiliary hydraulics and a 12 DC electrical source. They are controlled with a joystick and electrical valve. Although BRADCO does offer various options for connecting to existing electrical joystick controls, we will be covering the BRADCO operating controls in these instructions. The joystick control consists of 5 momentary toggle switches and is equipped to handle 3 blades, the gate and the rear stabilizers (if equipped).

SKID-STEER OR OTHER HOST MACHINE

The BRADCO Tree Spades mount to various host machines such as, but not limited to skid-steers, loaders, tractors and excavators. Due to the quantity of skid-steer applications, we will be referring to the host machine as a skid-steer loader throughout this manual.

The skid-steer must have front auxiliary hydraulics and a 12 Volt DC electrical power source available for spade operation. The **BRADCO** Tree Spades are NOT designed for use on high flow skid-steers.

Rear stabilizers are recommended to get the maximum performance of your tree spade. The rear stabilizers allow as much weight as possible to be transferred to the front of the skid-steer and therefore to the tree spade for maximum digging ability.

NOMENCLATURE

Throughout this manual, reference is made to various attachment components. The purpose of this section is to acquaint you with the various names of these components. This knowledge will be helpful when reading through the manual or when ordering service parts.

The blades are identified in a clockwise direction starting with the left rear spade.

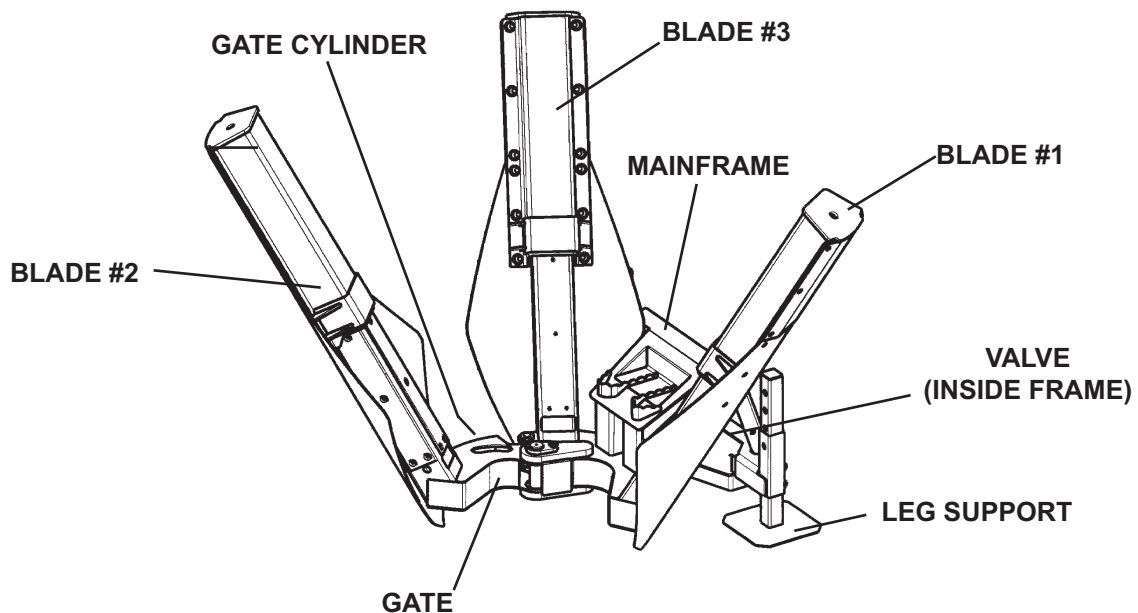

INSTALLATION

GENERAL INFORMATION

The following instructions will assist you in mounting your tree spade onto your skid-steer loader. The tree spade uses the quick attach mechanism for ease of installation. Therefore, if you know how to attach the loader bucket, attaching the tree spade should prove no problem.

NOTE: For mounting to other host machines see the specific mounting instructions that are supplied separately.

Remember to read all safety warnings, decals and operating instructions before operating the skid-steer loader or tree spade.

MOUNTING INSTRUCTIONS

1. Remove the steel shipping banding from around the tree spade and the skid.
2. Remove any attachment from the front of the skid-steer loader.
3. Set the quick attach locks on the skid-steer toolbar to the unlocked position. Lower the loader arms and tilt the toolbar down low enough to pass under the top lip of the hitch on the mainframe.
4. Following all standard safety practices, start the skid-steer and slowly drive it in back of the attachment. Position the loader so the top of the toolbar under the lip of the hitch on the mainframe.
5. Tilt the toolbar back to hook the attachment onto the toolbar. It may be necessary to lift the loader arms slightly.
6. Set the quick attach locks to the locked position to secure the tree spade onto the loader. It may be necessary to raise lower or tilt the toolbar to properly align so the locking mechanism can be activated.
7. Install your rear stabilizers (if so equipped) by following the instructions that were supplied rear stabilizers for your unit.
8. Connect the power and return hoses for the rear stabilizers to the two 90° elbows (part #3434) on the left side of the valve assembly.
9. With the auxiliary hydraulic system turned off, route the hydraulic hoses over the mainframe and connect them to their proper auxiliary couplers on the loader.

INSTALLATION

10. Connect the joystick assembly to the control cord from the tree spade. Connect the power cord from the joystick control to a power source on the skid-steer. **NOTE: There is an optional power plug adapter available for connecting to an auxiliary power outlet such as a cigarette lighter. Some host machines have an auxiliary electrical outlet to plug in the control cord and then use their own joystick controls.**

DANGER! ELECTROCUTION HAZARD



Provide electrical power to the joystick by following your skid-steer manufacturer's recommended procedures. The electrical circuit must be fused with a 10 amp fuse to prevent machine damage and serious personal injury or death.

11. Use plastic ties to secure the control cord extending from the tree spade mainframe to the hydraulic hoses to help keep it from interfering with operation of the tree spade and also to assist in keeping it free from pinching or chafing.
12. Complete the pre-delivery checklist located in the back of this manual. Tree Spade installation is now complete.

OPERATING INSTRUCTIONS

CONTROLS

GENERAL INFORMATION

Your tree spade is controlled by a joystick and an electrical valve assembly. Although BRADCO does offer various options for connecting to existing electrical joystick controls, we will be covering the BRADCO operating controls in these instructions. The joystick control consists of 5 momentary toggle switches and is equipped to handle three blades, the gate and rear stabilizers (if equipped).

BLADE CONTROLS

The joystick control can accommodate three blades and is wired for the number of blades on the tree spade you have purchased. Pushing the toggle switch up will raise that specific blade up, and pushing the toggle switch down will lower that blade. When the toggle switch is released, all movement will stop. The blade controls are located in the same pattern as the blades on the unit, with blade Number 1 being the closest blade to the operator on the left hand side (left rear blade).

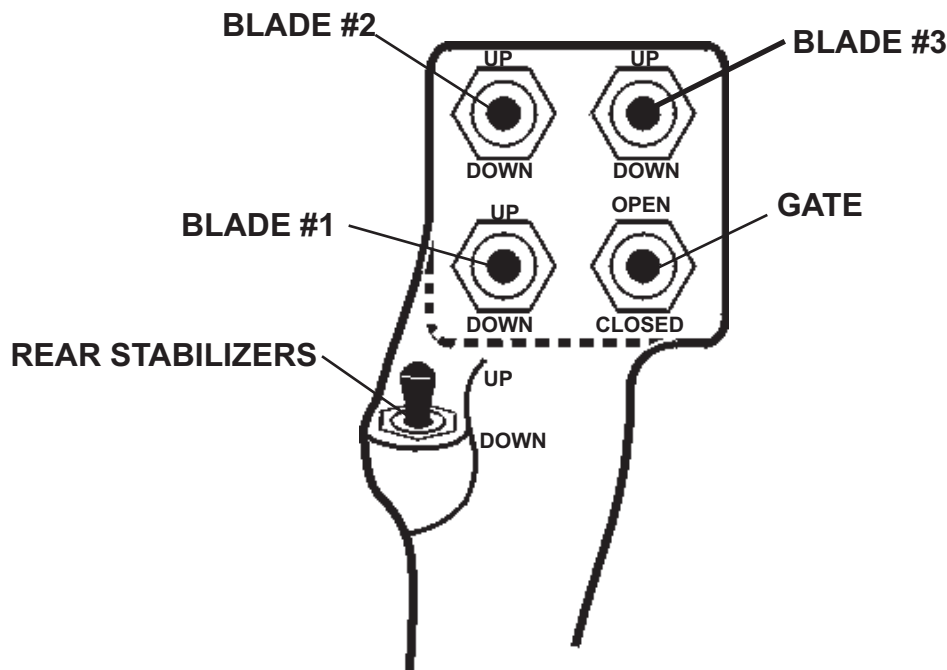

GATE CONTROL

The gate control operates in the same fashion as the blade controls. Pushing the toggle switch up will open the gate and pushing the toggle switch down will close the gate. When the toggle switch is released all movement will stop.

OPERATING INSTRUCTIONS

CONTROLS

REAR "JACK" STABILIZER CONTROL

The rear stabilizer control operates in the same fashion as the other controls. Pushing the toggle switch up will raise the left and right stabilizers and pushing the toggle switch down will lower the left and right stabilizer. When the toggle switch is released all movement will stop.

Rear stabilizer kits are available from your BRADCO dealer for fit up to various skid-steer loaders. The rear stabilizer hoses connect to the tree spade control valve and are therefore controlled by the operating control switch on the joystick.

Rear stabilizers are recommended to get the maximum performance from your tree spade. The rear stabilizers allow as much weight as possible to be transferred to the front of the skid-steer and therefore to the tree spade for maximum digging ability.

BALL SIZE GUIDELINES

The following information will assist you in determining the size of ball needed for the job at hand. These charts (*taken from the American Standard for Nursery Stock - ANSI Z60.1-1996*) are to be used as a guideline only and you should contact your local nursery for more detailed instructions.

Multi-Stem Trees or Shrubs

Height	Min. Dia. Ball
4'	14"
5'	16"
6'	18"
7'	20"
8'	22"

Deciduous Shrubs

Height	Min. Dia. Ball
12"	8"
18"	9"
2'	10"
3'	12"
4'	14"
5'	16"
6'	18"
7'	20"

Shade Trees

Caliper	Min. Dia. Ball
1/2"	12"
3/4"	14"
1"	16"
1-1/4"	18"
1-1/2"	20"
1-3/4"	22"

Small Trees

(Ht. up to 6' / Caliper 6' & over)

Ht./Caliper	Min. Dia. Ball
2'	10"
3'	12"
4'	14"
5'	16"
3/4"	16"
1"	18"
1-1/2"	20"
1-3/4"	22"

Coniferous Evergreens

Spreading/Semi-Spreading/Globe/Dwarf

Spread	Min. Dia. Ball
9"	8"
12"	8"
15"	10"
18"	10"
2'	12"
2-1/2'	14"
3'	16"
3-1/2'	18"
4'	21"

Coniferous Evergreens

Conical & Broad Uprights

Height	Min. Dia. Ball
12"	10"
18"	10"
2'	12"
3'	14"
4'	16"
5'	20"
6'	22"

Columnar Coniferous Evergreens
Regular Growing

Height	Min. Dia. Ball
12"	10"
18"	10"
2'	12"
3'	13"
4'	14"
5'	16"
6'	18"
7'	20"

Columnar Coniferous Evergreens
Rapid Growing

Height	Min. Dia. Ball
12"	8"
2'	9"
3'	11"
4'	12"
5'	14"
6'	16"

Broadleaf Evergreen
Cone and Upright

Height	Min. Dia. Ball
18"	10"
2'	12"
3'	14"
4'	16"
5'	20"
6'	22"

OPERATING INSTRUCTIONS

Broadleaf Evergreen Spreading/Semi-Spreading/ Globe/Dwarf

Spread	Min. Dia. Ball
18"	10"
2'	12"
2-1/2'	14"
3'	16"
3-1/2'	18"
4'	21"

Processed Balled Fruit Trees

Caliper	Min. Dia. Ball
1/4"	8"
5/16"	8"
3/8"	10"
31/2"	10"
5/8"	10"
3/4"	12"
1" & UP	12"

In sizing shade trees, caliper shall take precedence over height. In size grading small and flowering trees, height shall take precedence up to 6 feet; thereafter, caliper takes precedence.

Caliper of the trunk shall be taken 6 inches above the ground up to and including 4 inch caliper size, and 12 inches above the ground for larger sizes. (Seldom are tree trunks perfectly round. Caliper measurement may be taken with "slot" type caliper, "pincer" type calipers or diameter tape.)

The diameter of the ball is determined by the blade size or the digging depth. Each blade is changed by removing one pin. The ball depth is determined by the position of the adjustable legs.

On larger bushy trees the branches may have to be tied up so the blades do not cut off the lower branches.

On some types of trees it is recommended for best results that transplanting take place while the tree is dormant. Contact your local nursery for the specifications on the type of tree you are transplanting.

GENERAL OPERATING INFORMATION

The BRADCO Tree Spades are designed to meet the needs of the professional nurseryman. The machine has proven capable of continuous digging with a minimum of maintenance. It is used extensively for removing trees for burlapping and for transplanting and rearranging nursery rows.

NOTE: These instructions include the use of rear "jack" stabilizers. Rear stabilizer kits are available from your BRADCO dealer for fit up to various skid-steer loaders. The rear stabilizer hoses connect to the tree spade control valve and are therefore controlled by the operating control switch on the joystick. Rear stabilizers are recommended to get the maximum performance from your tree spade. The rear stabilizers allow as much weight as possible to be transferred to the front of the skid-steer and therefore to the tree spade for maximum digging ability.

IMPORTANT: Always follow the instructions in your skid-steer loader operators manual for operating the auxiliary hydraulic controls and follow the Safety Shutdown Procedure whenever leaving the operators station of the skid-steer.

OPERATING INSTRUCTIONS

After the tree spade has been properly attached, raise the unit above the ground approximately 2 feet. Acquaint yourself with the various control levers. After becoming familiar with the controls it is advisable to dig in soil without a tree. This will provide an opportunity to check ball size as well as attachment operation.

The blades on the tree spade are number 1, 2, and 3. The forward blade opens when the gate control is pushed forward.

Soil condition and type affect how the tree spade operates. In firm soil the blades may travel only one-third of the way down on the first stroke and in loose or sandy soil the blades may penetrate completely in one stroke.

The amount of root ball needed will vary per the diameter of the tree trunk, the height of the tree or the type of tree. Refer to the charts at the beginning of this section. A general rule of thumb is every one inch of tree diameter requires a minimum of ten inch ball diameter.

ADJUSTING LEG HEIGHT

The tree spades are equipped with adjustable legs that are used for adjusting the ball size. With the legs fully raised the ball size will be the rated size of your tree spade. Moving the legs down will decrease the ball size approximately 2.00" for each adjustment hole. If the legs are removed completely the tree spade will dig a slightly larger hole than rated size.

Lift and block the spade before making any leg adjustment.

BALLED AND BURLAPPED TREES (WITH OR WITHOUT WIRE BASKET)

NOTE: There are a wide range of presewn burlap bags, wire baskets and containers available from reputable manufacturers for the BRADCO Tree Spade.

Determine the size of ball required for the type and size of tree. Adjust the legs to achieve the desired ball size.

CAUTION: TO AVOID CYLINDER DAMAGE:



**DO NOT OPEN GATE WHEN THE BLADES ARE DOWN.
DO NOT LOWER BLADES WHEN THE GATE IS OPEN.**

1. With the gate open and the blades in the up position, center the tree in the tree spade from left to right: and front to back. **NOTE: It is CRITICAL that the tree is centered in the ball. Therefore, it is advisable to have someone on the ground to aid in the alignment process.**
2. Close the gate.
3. Lower the loader arms, therefore raising the front wheels off the ground.
4. Lower the rear stabilizers (if so equipped), until the loader feels level.

NOTE: Raising the loader until the wheels are only slightly off the ground transfers the weight to the tree spade for maximum digging power. Lifting the loader too high may cause an unstable condition.

5. Roll the tree spade until it is level.

OPERATING INSTRUCTIONS

6. Once the tree spade is level, the loader raised slightly and the gate closed, it is time to start lowering the blades. Using the joystick control, lower "Blade 1" as far as it will go into the soil. (Due to the different soil conditions the blade may go all the way into the ground or only slightly.)
7. As soon as the blade starts to tilt the attachment, stop movement and raise the blade slightly to remove some of the down pressure. (This will assist in digging the maximum ball size and prevent digging an angled hole.)
8. Using the joystick control, lower "Blade 2" as far as it will go into the soil. As soon as the blade starts to tilt the attachment, stop movement and raise the blade slightly to remove some of the down pressure. Repeat for "Blade 3).
9. If the blades failed to lower completely due to the soil conditions, repeat Steps #6 thru #8 until all the blades are completely lowered into the soil.
10. Raise the rear stabilizers, (if so equipped).
11. Raise the loader arms until the wheels are fully on the ground. Lift the tree out of the hole.
12. Placing the burlap on the ground or in the wire basket, position the tree in the center of the burlap. **NOTE: Carry the tree as low as possible when transporting.**
13. Release the ball by first raising "Blade 3", and continue to raise the blades in reverse order 2, & 1. **NOTE: If the tree ball sticks to the blades, use a shovel to press down on the tree ball to loosen it from the blades.**
14. Lift the tree spade slightly, and open the gates. Back the loader away from the tree. The ball is ready for covering, with no additional shaping necessary.
15. Finish wrapping the tree.

Direct Transplanting

1. Determine the size of hole needed for the tree you are transplanting, and adjust the legs to achieve the desired hole size.
2. Raise the blades and drive the skid steer to the location that the tree will be planted and position the skid-steer so the loader is as level as possible. Follow Steps 2 thru 11 in the previous instructions (Balled and Burlapped Trees) to dig a spot for the tree.
3. Lift the dirt ball out of the ground and move out of the way for tree transplanting. Set the tree spade on the ground and raise the blades to release the dirt ball. The blades should be raised in reverse order 3, 2 and 1. Open gate.
4. See Steps 1 thru 11 in the previous instructions (Balled and Burlapped Trees) to dig up the desired tree for transplanting.
5. Position the tree over the previously dug hole, and while keeping the tree trunk as vertical as possible, lower the tree.
6. Release the ball by first raising "Blade 3" and continue to raise the blades in reverse order 2, & 1. **NOTE: If the tree ball sticks to the blades, use a shovel to press down on the tree ball to loosen it from the blades.**
7. Lift the tree spade slightly and open the gate. Back the loader away from the tree. **NOTE: Follow any specific transplanting instructions, such as watering and mulching etc., for the type of tree you are transplanting.**

OPERATING INSTRUCTIONS

GENERAL INFORMATION

The following storage procedure will help you to keep your attachment in top condition. It will also help you get off to a good start the next time your tree spade is needed. We therefore, strongly recommend that you take the extra time to follow these procedures whenever your attachment will not be used for an extended period of time.

PREPARATION FOR STORAGE

1. Clean the exterior thoroughly removing all mud, dirt and grease.
2. Inspect the unit for visible signs of wear. Order any parts required and make any necessary repairs to avoid delays when starting next season.
3. Inspect the graphite coating on the blades. Repaint as needed.
4. Check the blades for wear. If sharpening is required use a hand grinder.
5. Tighten all loose nuts and capscrews.
6. Grease all grease fittings.
7. Coat the exposed portions of the cylinder rods with grease.
8. Connect the hydraulic couplers together to protect the hydraulic system from contaminants. (Cap the fittings for the rear stabilizers.)
9. Replace decals if damaged or in unreadable condition.
10. Store the unit in a dry and protected place. Leaving the unit outside will materially shorten its life.

REMOVING FROM STORAGE

1. Remove all protective coverings.
2. Check hydraulic hoses for deterioration and replace if necessary.

TRANSPORTING

1. Follow all federal, state and local regulations when transporting the unit on public roads.
2. Use extra care when loading or unloading the machine onto a trailer or truck.
3. Before transporting, raise the blades and keep the unit as close to the ground as possible.

CAUTION! Be sure to install a SMV (Slow Moving Vehicle) sign on the loader before attempting to transport.



When transporting on a road or highway at night or during the day, use accessory lights and devices for adequate warning to the operators of other vehicles. In this regard, check local government regulations.

Always drive slowly over uneven terrain to avoid tipping the unit.

MAINTENANCE AND SERVICE

GENERAL INFORMATION

Regular maintenance is the key to long equipment life and safe operation. Maintenance requirements have been reduced to an absolute minimum. However, it is very important that these maintenance functions be performed as described below.

LUBRICATION

Lubricate all grease fittings with a multi-purpose grease.

DAILY

Physically check all pins, bushings, cotter pins, nuts, etc., for signs of wear or loose fit. Tighten as required, replace where necessary.
Clean equipment of all dirt, oil, and excess grease.
Check for missing or illegible Safety / Warning Decals.
Check all fittings and hydraulic hoses for leaks.

WARNING! Escaping hydraulic / diesel fluid under pressure can penetrate the skin causing serious injury. Fluid escaping from a very small hole can be almost invisible. Use a piece of cardboard or wood, rather than hands to search for suspected leaks.



Keep unprotected body parts, such as face, eyes, and arms as far away as possible from a suspected leak. Flesh injected with hydraulic fluid may develop gangrene or other permanent disabilities. If injured by injected fluid, see a doctor at once.

Stop the engine and relieve pressure before connecting or disconnecting lines.

Tighten all connections before starting engine or pressurizing lines.

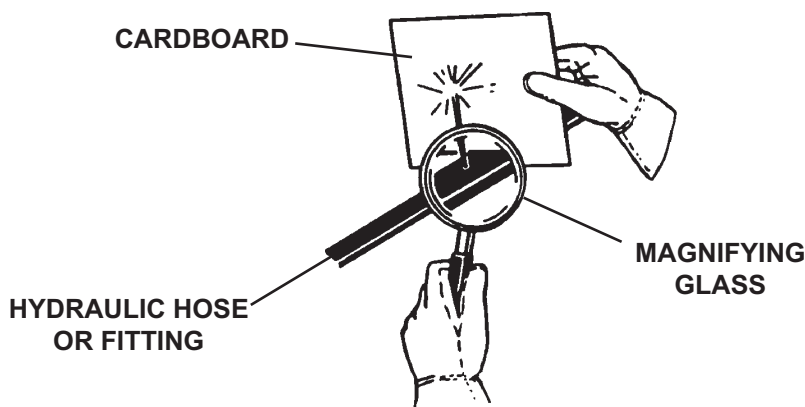

MAINTENANCE AND SERVICE



WARNING! Be sure to follow Safety Shutdown Procedures before performing any maintenance on attachment.

LUBRICATION

Lubricate all grease fittings daily or after every 8 hours of operation. There are three grease fittings on the 2030 tree spade. One on each end of the Gate Cylinder and one on the Gate Pivot Pin. **NOTE: A scraping sound during operation is an indication that the slide channel and slider bars require lubricating.**

BLADE MAINTENANCE

Maintaining the condition of the blades will result in a cleaner ball and a smoother digging operation. The blades are painted before shipping. This prevents the earth from sticking to the blades and aids in the digging operation. The performance of the blade is affected by soil conditions and can be repainted or coated with Slip Plate #1, manufactured by Acrotech Industries Inc. One gallon of Slip Plate #1 can be purchased from BRADCO under part #25154. It is important that oil not be used on the blades as long as the graphite coating remains.

SHARPENING BLADES

Although the blades should remain in good condition for a long time, extensive use and rocky soil conditions may dull portions of the blades. If sharpening is required, use a hand grinder and sharpen the blades in an even pattern.

REPLACING BUSHINGS

To Replace Arm Bushings:

1. Lower the mainframe onto the rear legs as close to the ground as possible, and block up the front of the mainframe to keep it level.
2. Remove Blades #2 and #3.
3. Disconnect the gate cylinder at the arm weldment.
4. Attach a hoist to the arm to prevent it from falling and causing cylinder damage, personal injury or undue stress to the hoses when it is disconnected from the mainframe.

NOTE: If you are removing the arm completely for bushing replacement, the blade cylinder hoses will need to be tagged and removed.

5. With the arm supported, remove the pivot pin securing the arm to the mainframe. While continuing to support the arm, press out the top and bottom bushing and replace with new.
6. Position the arm, and replace the pivot pin.
7. Connect the gate cylinder to the arm weldment.
8. Reinstall Blades #2 and #3.
Bushing replacement is complete.

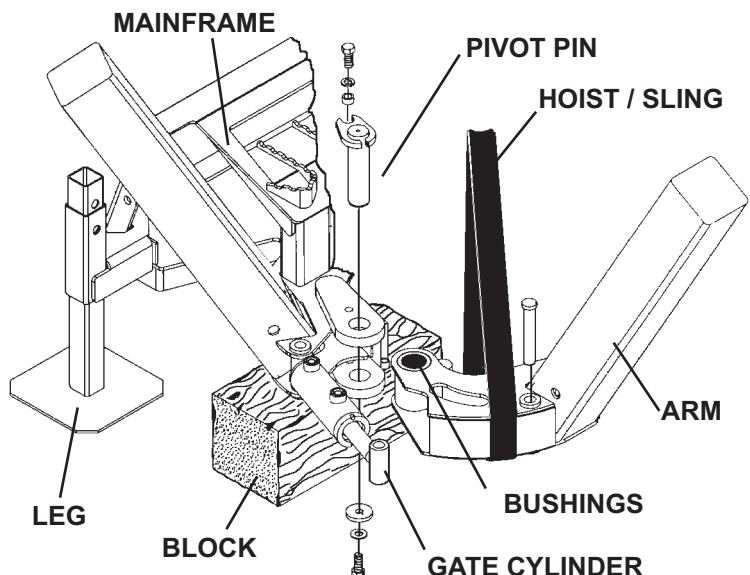

MAINTENANCE AND SERVICE

BLADE ADJUSTMENT

Proper adjustment of the blades is required for best performance of the tree spade. Loose blades hinder the spades ability to cut the roots. As the blades and plastic wear plates begin to wear, the blades may need to be adjusted to maintain the close positioning of the blades and prevent gapping between the blades. There are shims provided between the tower and the blades and the tower and the tower cover that can be removed (to tighten the tower on the mainframe) or moved to the opposite side (to maintain blade tightness).

To adjust blades:

1. Loosen the .50" capscrews securing the tower cover and blades to the tower.
2. Slide in a shim or remove a shim as required to maintain blade tightness.

(NOTE: Keep all shims for future adjustments.)

3. Re-tighten capscrews and check the blade positioning.

NOTE: Once the blades can no longer be adjusted the wear plate(s) will need to be replaced.

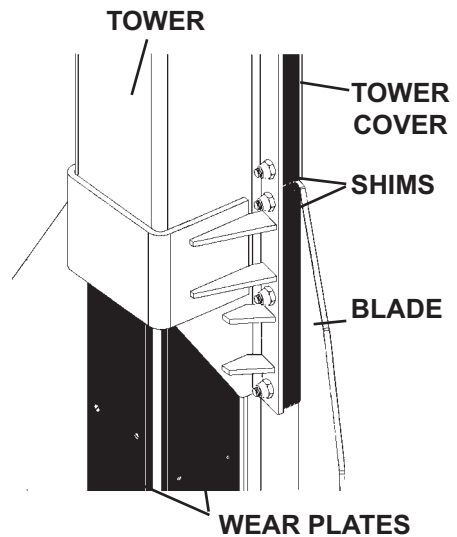

WEAR PLATE REPLACEMENT

If the wear plate(s) have worn to the point that the towers are riding on the capscrews or when the blades have reached the end of their adjustment and gapping between the blades is still evident the wear plate(s) will need to be replaced.

To replace wear plates:

1. Remove the blade and the tower cover from the tower.
2. Position a wrench on the flat spot of the blade cylinder to prevent it from rotating as you remove the lock nut securing the blade to the tower.
3. Remove the tower and inspect the wear plates. Replace any wear plates that are worn. **NOTE: There are two different style wear plates on each slide tower. The front wear plate is a harder plastic than the remaining three.**
4. Drill out the rivets to remove the wear plate. Install new wear plate with new rivets (#10104) into the existing holes and secure by driving the center pin with a hammer.
5. Re-install the tower and secure the blade cylinder to the tower using the hardware removed in step #2.
6. Install the tower cover to the tower while inserting all of the original shims.
7. Install the blade to the tower while inserting all of the original shims.
8. Check blade position. Insert or remove shims as required to obtain blade tightness.

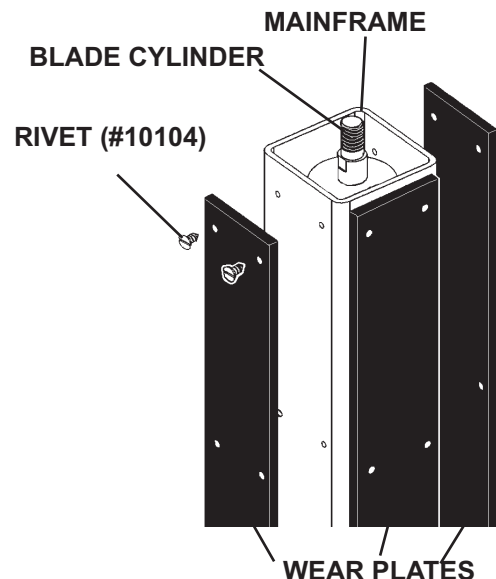

10517 3-3-06

MAINTENANCE AND SERVICE

CYLINDER SEAL REPLACEMENT

The following information is provided to assist you in the event you should need to repair or rebuild a hydraulic cylinder. When working on hydraulic cylinders, make sure that the work area and tools are clean and free of dirt to prevent contamination of the hydraulic system and damage to the hydraulic cylinders. Always protect the active part of the cylinder rod (the chrome section). Nicks or scratches on the surface of the rod could result in cylinder failure. Clean all parts thoroughly with a cleaning solvent before reassembly.

DISASSEMBLY PROCEDURE

IMPORTANT: Do not contact the active surface of the cylinder rod with the vise. Damage to the rod could result.

THREADED TYPE GLAND

1. Rotate the gland with a spanner wrench counterclockwise until the gland is free of the cylinder tube.
2. Pull the cylinder rod from the cylinder tube and inspect the piston and the bore of the cylinder tube for deep scratches or galling. If damaged, the piston AND the cylinder tube must be replaced.

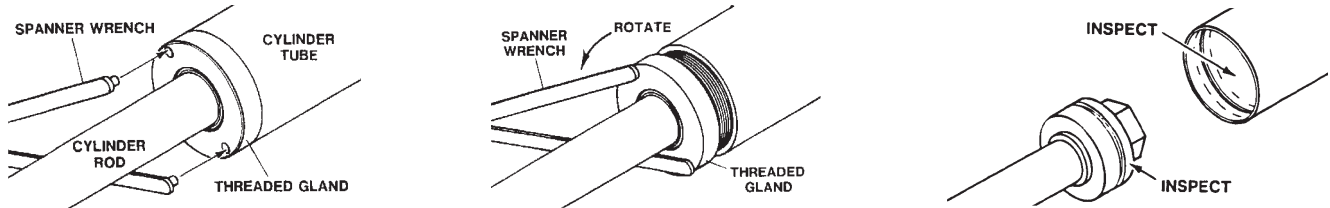

3. Remove the hex nut, piston, flat washer or spacer tube (if so equipped), and gland from the cylinder rod. If the cylinder rod is rusty, scratched, or bent, it must be replaced.
4. Remove and discard all the old seals.

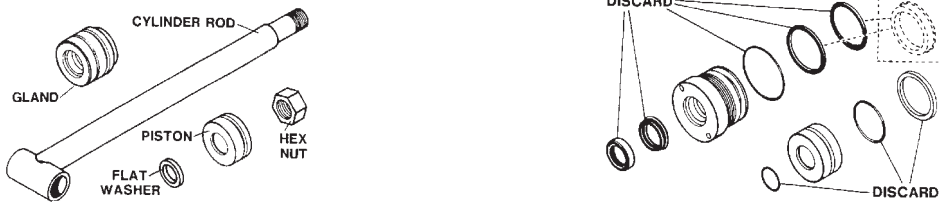

ASSEMBLY PROCEDURE

IMPORTANT: Replace all seals even if they do not appear to be damaged. Failure to replace all seals may result in premature cylinder failure. **NOTE:** Seal kits will service most cylinders of similar bore size and rod diameter.

1. Install the cylinder rod seal in the gland first. Be careful not to damage the seal in the process, as it is somewhat difficult to install.

NOTE: A special installation tool (Part #65349) is available to help with installing the seal. Simply fit the end of the tool over the seal so that the large prong of the tool is on the outside of the seal, and the two smaller prongs on the inside. The lip of the seal should be facing towards the tool. Rotate the handles on the tool around to wrap the seal around the end of the tool.

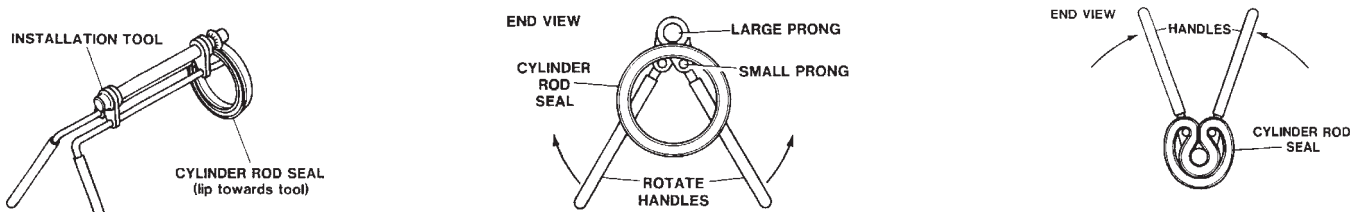

10356 10-13-05

MAINTENANCE AND SERVICE

Now insert the seal into the gland from the inner end. Position the seal in its groove, and release and remove the tool. Press the seal into its seat the rest of the way by hand.

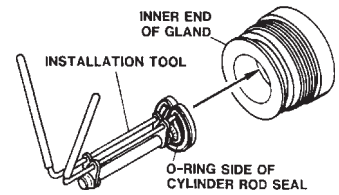

2. Install the new piston ring, rod wiper, O-rings and backup washers, if applicable, on the piston.

Be careful not to damage the seals. Caution must be used when installing the piston ring. The ring must be stretched carefully over the piston with a smooth, round, pointed tool.

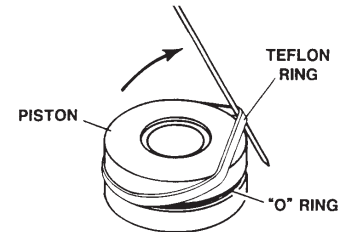

3. After installing the rod seal inside the gland, as shown in step #1, install the external seal.

NOTE: Threaded glands may have been equipped with a separate O-ring and backup washer system or a polypak (all in one) type seal. Current seal kits contain a polypak (all in one) type seal to replace the discarded seal types on ALL THREADED GLANDS.

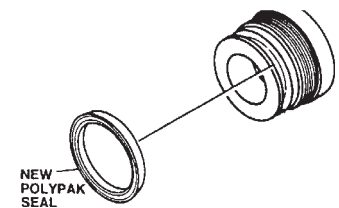

4. Slide the gland onto the cylinder rod, being careful not to damage the rod wiper. Then install the spacer, or flat washer (if so equipped), small o-ring, piston, and hex nut onto the end of the cylinder rod.
5. Secure the cylinder rod (mounting end) in a vise with a support at its center. Torque the nut to the amount shown for the thread diameter of the cylinder rod (see chart).

Thread Diameter	POUNDS - FEET
7/8"	150-200
*1"	230-325
1-1/8"	350-480
1-1/4"	490-670
1-3/8"	670-900
* 1" Thread Diameter WITH 1.25" Rod Diameter Min. 230 ft. lbs. Max. 250 ft. lbs.	

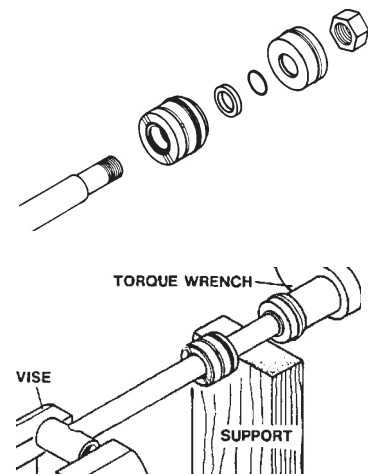

IMPORTANT: Do not contact the active surface of the cylinder rod with the vise. Damage to the rod could result.

6. Apply a lubricant (such as Lubriplate #105) to the piston and teflon ring. Insert the cylinder rod assembly into the cylinder tube.

IMPORTANT: Ensure that the piston ring fits squarely into the cylinder tube and piston groove, otherwise the ring may be damaged and a leak will occur.

7. Use a spanner wrench to rotate the gland clockwise into the cylinder. Continue to rotate the gland with the spanner wrench until it is tight.

WARNING! Cylinders serviced in the field are to be tested for leakage prior to the attachment being placed in work. Failure to test rebuilt cylinders could result in damage to the cylinder and/or the attachment, cause severe personal injury or even death.



TROUBLESHOOTING

<u>PROBLEM</u>	<u>POSSIBLE CAUSE</u>	<u>POSSIBLE REMEDY</u>
Tree Spade will not operate.	Auxiliary hoses not hooked up to the skid-steer.	Engage Couplers
	Obstruction in hydraulic lines.	Remove obstruction and re-place if necessary.
	Skid-steer auxiliary valve not engaged.	Engage auxiliary valve.
	Loss of electrical power to joystick control.	Check electrical connection and circuit fuse.
Blades activate sluggishly.	Insufficient hydraulic flow from the skid-steer.	Refer to skid-steer's owners manual.
	Damaged quick coupler.	Replace if necessary.
	Oil filter on skid-steer is dirty.	Refer to skid-steer's owners manual.
Leaking Oil.	Loose or damaged hydraulic line.	Tighten or replace.
	O-Rings on fittings damaged.	Replace if necessary.
	Fittings loose or damaged.	Tighten or replace.
	Cylinder seals damaged.	Replace cylinder seals.
Insufficient power.	Insufficient hydraulic flow from the skid-steer.	Refer to skid-steer's owners manual.
	Relief valve setting adjusted too low.	Refer to skid-steer's owners manual.
	Oil filter on skid-steer is dirty.	Refer to skid-steer's owners manual.
	Blades worn or chipped.	Sharpen as needed.
Cylinders operate in the wrong direction.	Hoses from the valve to the skid-steer incorrectly connected.	Switch couplers at the skid steer end.
	Incorrect wiring from the joystick control.	Check wiring diagram and correct.

TROUBLESHOOTING

<u>PROBLEM</u>	<u>POSSIBLE CAUSE</u>	<u>POSSIBLE REMEDY</u>
Excessive oil temperature.	Hydraulic oil level too low.	Refer to skid-steer's owners manual
	Obstruction in hydraulic lines.	Remove obstruction and replace if necessary.
	Hydraulic oil or oil filter in skid-steer is dirty.	Refer to skid-steer's owners manual.
	Relief valve setting adjusted too low.	Refer to skid-steer's owners manual.
	Couplers not engaged.	Engage couplers.
A hydraulic cylinder not operating.	Insufficient hydraulic flow from the skid-steer.	Refer to skid-steer's owners manual.
	Cylinder rod bent.	Visually inspect the cylinder for damage.
	Cylinder seals damaged.	Replace cylinder seals.
	Obstruction in hydraulic lines.	Remove obstruction and replace if necessary.
	An electrical coil not functioning at valve.	Check voltage readings at valve and replace coil if necessary.
All hydraulic cylinders not functioning.	Blown fuse on skid-steer.	Refer to skid-steer's owners manual.
	Damaged electrical wiring.	Test and replace if necessary.
	Loss of hydraulic power.	Check hydraulic circuit.
	Electrical power connected to wrong polarity.	Reverse red and black wires.
Hydraulic cylinders only operating in one direction.	Contaminants in the hydraulic system and solenoid valve.	Remove spool from solenoid valve and check for foreign material. Clean or replace. Remove spool from solenoid valve and check seals for damage. Replace if necessary.
	Damaged electrical wiring.	Test and replace if necessary.
	Bad electrical connection at Reversing valve.	Check connections and correct.
	Coil or spool damaged in reversing valve.	Replace as necessary.



BOLT TORQUE

BOLT TORQUE SPECIFICATIONS

GENERAL TORQUE SPECIFICATION TABLE

Use the following torques when special torques are not given. These values apply to fasteners as received from suppliers, dry, or when lubricated with normal engine oil. They do not apply if special graphited or moly disulphide greases or other extreme pressure lubricants are used. This applies to both UNF and UNC threads. Remember to always use grade five or better when replacing bolts.

IMPORTANT: On all PLATED GRADE 8 bolts, reduce torque 15% from listed bolt torque specification.

SAE Grade No.		2				5				8*			
Bolt head identification marks as per grade. NOTE: Manufacturing Marks Will Vary													
		TORQUE		TORQUE		TORQUE		TORQUE		TORQUE		TORQUE	
Bolt Size		Pounds Feet		Newton-Meters		Pounds Feet		Newton-Meters		Pounds Feet		Newton-Meters	
Inches	Millimeters	Min.	Max.	Min.	Max.	Min.	Max.	Min.	Max.	Min.	Max.	Min.	Max.
1/4	6.35	5	6	7	8	9	11	12	15	12	15	16	20
5/16	7.94	10	12	14	16	17	20.5	23	28	24	29	33	39
3/8	9.53	20	23	27	31	35	42	48	57	45	54	61	73
7/16	11.11	30	35	41	47	54	64	73	87	70	84	95	114
1/2	12.70	45	52	61	70	80	96	109	130	110	132	149	179
9/16	14.29	65	75	88	102	110	132	149	179	160	192	217	260
5/8	15.88	95	105	129	142	150	180	203	244	220	264	298	358
3/4	19.05	150	185	203	251	270	324	366	439	380	456	515	618
7/8	22.23	160	200	217	271	400	480	542	651	600	720	814	976
1	25.40	250	300	339	406	580	696	787	944	900	1080	1220	1464
1-1/8	25.58	-	-	-	-	800	880	1085	1193	1280	1440	1736	1953
1-1/4	31.75	-	-	-	-	1120	1240	1519	1681	1820	2000	2468	2712
1-3/8	34.93	-	-	-	-	1460	1680	1980	2278	2380	2720	3227	3688
1-1/2	38.10	-	-	-	-	1940	2200	2631	2983	3160	3560	4285	4827

* Thick Nuts must be used with Grade 8 bolts

METRIC BOLT TORQUE SPECIFICATIONS

Size of Screw	Grade No.	Coarse Thread			Fine Thread		
		Ptich (mm)	Pounds Feet	Newton-Meters	Pitch (mm)	Pounds Feet	Newton-Meters
M6	5.6	1.0	3.6-5.8	4.9-7.9	-	-	-
	8.8		5.8-4	7.9-12.7		-	-
	10.9		7.2-10	9.8-13.6		-	-
M8	5.6	1.25	7.2-14	9.8-19	1.0	12-17	16.3-23
	8.8		17-22	23-29.8		19-27	25.7-36.6
	10.9		20-26	27.1-35.2		22-31	29.8-42
M10	5.6	1.5	20-25	27.1-33.9	1.25	20-29	27.1-39.3
	8.8		34-40	46.1-54.2		35-47	47.4-63.7
	10.9		38-46	51.5-62.3		40-52	54.2-70.5
M12	5.6	1.75	28-34	37.9-46.1	1.25	31-41	42-55.6
	8.8		51-59	69.1-79.9		56-68	75.9-92.1
	10.9		57-66	77.2-89.4		62-75	84-101.6
M14	5.6	2.0	49-56	66.4-75.9	1.5	52-64	70.5-86.7
	8.8		81-93	109.8-126		90-106	122-143.6
	10.9		96-109	130.1-147.7		107-124	145-168
M16	5.6	2.0	67-77	90.8-104.3	1.5	69-83	93.5-112.5
	8.8		116-130	157.2-176.2		120-138	162.6-187
	10.9		129-145	174.8-196.5		140-158	189.7-214.1
M18	5.6	2.0	88-100	119.2-136	1.5	100-117	136-158.5
	8.8		150-168	203.3-227.6		177-199	239.8-269.6
	10.9		175-194	237.1-262.9		202-231	273.7-313
M20	5.6	2.5	108-130	146.3-176.2	1.5	132-150	178.9-203.3
	8.8		186-205	252-277.8		206-242	279.1-327.9
	10.9		213-249	288.6-337.4		246-289	333.3-391.6

10360 6-8-95-2

SPECIFICATIONS

2030 TREE SPADE

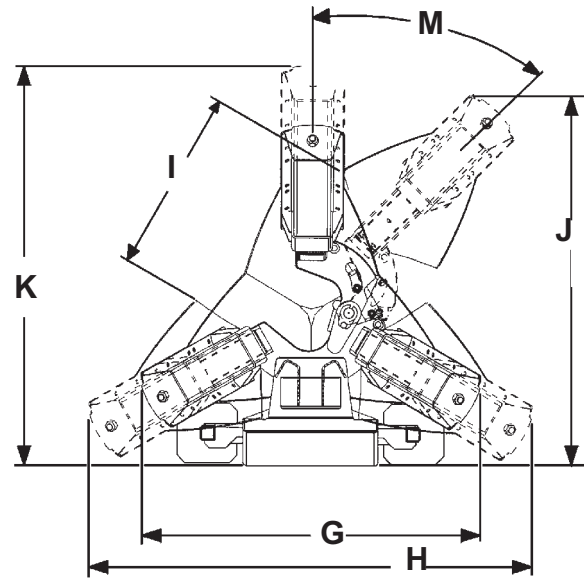
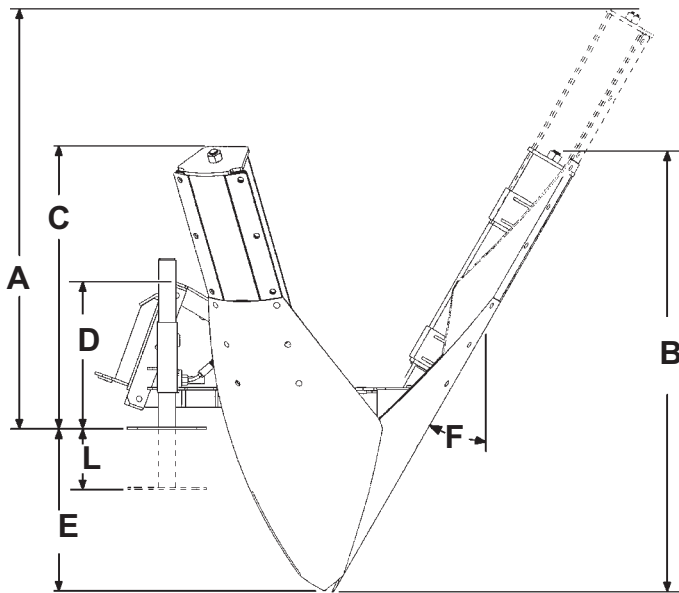

DESCRIPTION	2030
A. Overall Height - Blades Up (Open)	42.25"
B. Overall Height - Blades Down (Closed)	44.51"
C. Shipping Height - (Blades Removed).....	28.38"
D. Frame Height	14.75"
E. Digging Depth	16.13"
F. Cutting Angle.....	30°
G. Overall Transport Width (Gate Closed).....	45.50"
H. Overall Width (Gate Open)(Blades Up)	59.50"
I. Maximum Gate Opening	26.00"
J. Overall Length (Gate Open).....	49.00"
K. Overall Transport Length (Gate Closed)	53.50"
L. Maximum Leg Adjustment.....	6.00"
M. Gate Swing	45°
Number of Blades	3
Tree Ball Diameter	16" - 20"
Tree Diameter.....	1.00" - 1.50"
1.00" - 1.50"Ball Weight (LBS).....	80-120 LBS
Flow Requirements (GPM)	6
Recommended Operating Pressure (PSI).....	2000
Weight (LBS)	525
Specification and design are subject to change without notice and without liability therefore.	

LIMITED WARRANTY

All new Bradco products are warranted to be free from defects in materials or workmanship which may cause failure under normal usage and service when used for the purpose intended.

In the event of failure within twenty four (24) months from initial retail sale, lease or rental date (excluding cable, ground engaging parts such as sprockets, digging chain, bearings, teeth, tamping and demolition heads, blade cutting edges, pilot bits, auger teeth, auger heads & broom bristles), if after examination, Bradco determines failure was due to defective material and/or workmanship, parts will be repaired or replaced. Bradco may request defective part or parts be returned prepaid to them for inspection at their place of business at Delhi, Iowa, or to a location specified by Bradco.

Any claims under this warranty must be made within fifteen (15) days after the Buyer learns of the facts upon which such claim is based. All claims not made in writing and received by Bradco within the time period specified above shall be deemed waived.

THIS WARRANTY IS IN LIEU OF ALL OTHER WARRANTIES EXPRESSED OR IMPLIED AND THERE ARE NO WARRANTIES OF MERCHANTABILITY OR OF FITNESS FOR A PARTICULAR PURPOSE. IN NO EVENT SHALL BRADCO BE LIABLE FOR CONSEQUENTIAL OR SPECIAL DAMAGE.

BRADCO'S LIABILITY FOR ANY AND ALL LOSSES AND DAMAGES TO BUYER, RESULTING FROM ANY CAUSE WHATSOEVER, INCLUDING BRADCO'S NEGLIGENCE, IRRESPECTIVE OF WHETHER SUCH DEFECTS ARE DISCOVERABLE OR LATENT, SHALL IN NO EVENT EXCEED THE PURCHASE PRICE OF THE PARTICULAR PRODUCTS WITH RESPECT TO WHICH LOSSES OR DAMAGES ARE CLAIMED, OR, AT THE ELECTION OF BRADCO, THE REPAIR OR REPLACEMENT OF DEFECTIVE OR DAMAGED PRODUCTS.

2030 TREE SPADE ASSEMBLY

ASSEMBLY #25605

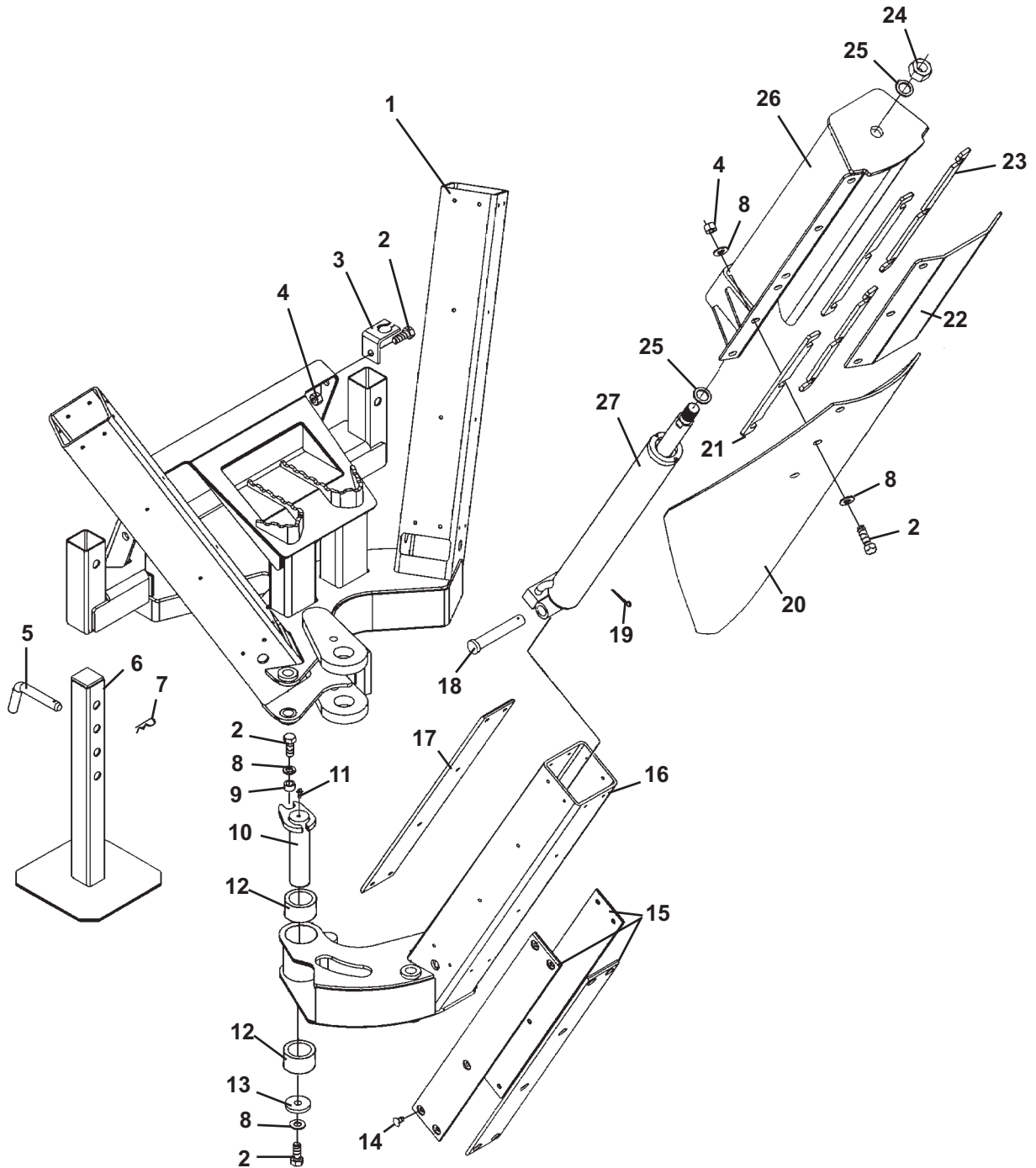

2030 TREE SPADE ASSEMBLY

ASSEMBLY #25605

<u>ITEM</u>	<u>REQ'D</u>	<u>PART NO.</u>	<u>DESCRIPTION</u>
1	1	25479	Mainframe
2	44	1089	.50 UNC X 1.25" Hex Capscrew
3	1	25802	Harness Bracket
4	42	1841	.50" UNC Deformed Lock Nut
5	2	89951	Hitch Pin (Includes Hairpin)
6	2	31034	Leg
7	2	1860	Replacement Hairpin
8	74	1646	.50" Hard Flat Washer
9	1	17942	Spacer Tube
10	1	25510	Pivot Pin
11	1	6616	Grease Fitting
12	2	81828	Bushing (Included in Arm)
13	1	31394	Special Washer
14	72	10104	Drive Rivet
15	9	25472	Wear Plate
16	1	25480	Arm
17	3	25609	Wear Plate (Inside)
18	3	22260	Cylinder Pin
19	3	1611	Cotter Pin
20	3	25457	Blade
21	12	25662	Shim 1.50" X 11.25"
22	3	25474	Tower Cover
23	12	25504	Shim 1.50" X 14.25"
24	3	1482	.88" UNC Deformed Lock Nut
25	6	1845	.88" Hard Flat Washer
26	3	25478	Tower
27	3	25463	Cylinder Assembly (Replacement Seal Kit #45581)

2030 TREE SPADE ASSEMBLY

ASSEMBLY #25605

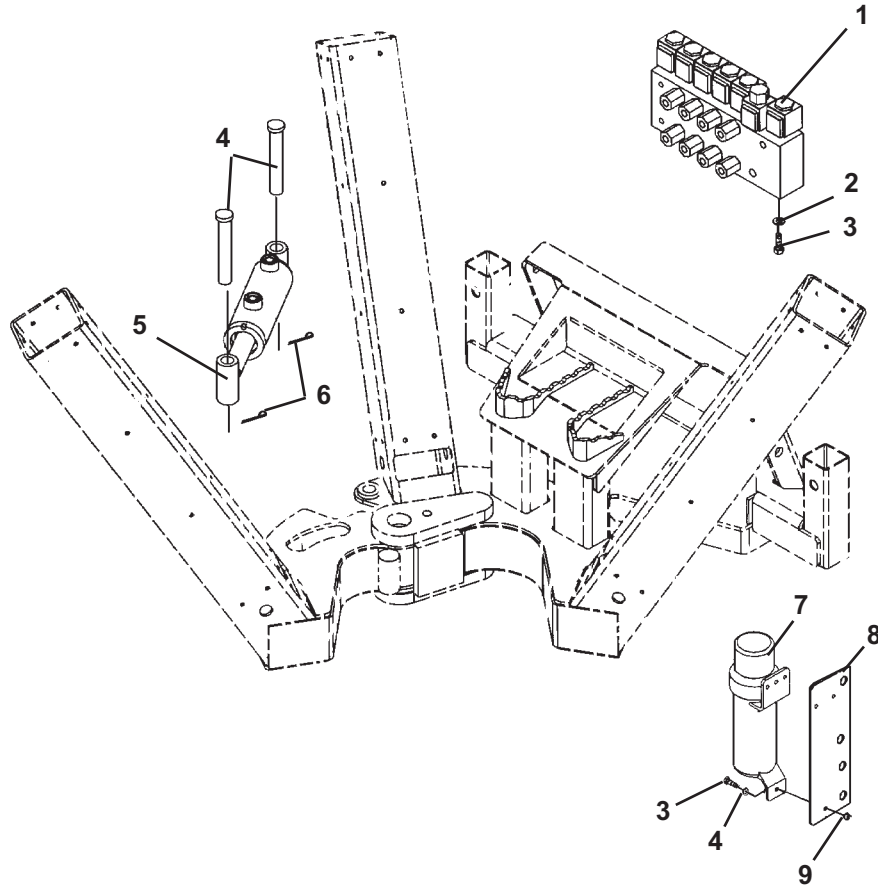

2030 TREE SPADE ASSEMBLY

ASSEMBLY #25605

<u>ITEM</u>	<u>REQ'D</u>	<u>PART NO.</u>	<u>DESCRIPTION</u>
1	1	25804	Joystick Valve and Harness Assembly
2	5	1513	.31" Flat Washer
3	5	1022	.31" UNC X 1.00" Hex Capscrew
4	2	22260	Cylinder Pin
5	1	25458	Cylinder Assembly (Replacement Seal Kit #45581)
6	2	1611	Hair Pin
7	1	25453	Manual Storage Tube
8	1	25803	Manual Mounting Plate
9	3	1753	.31" UNC Nylock Nut

10178 2-27-06

MOUNTING KIT ASSEMBLIES

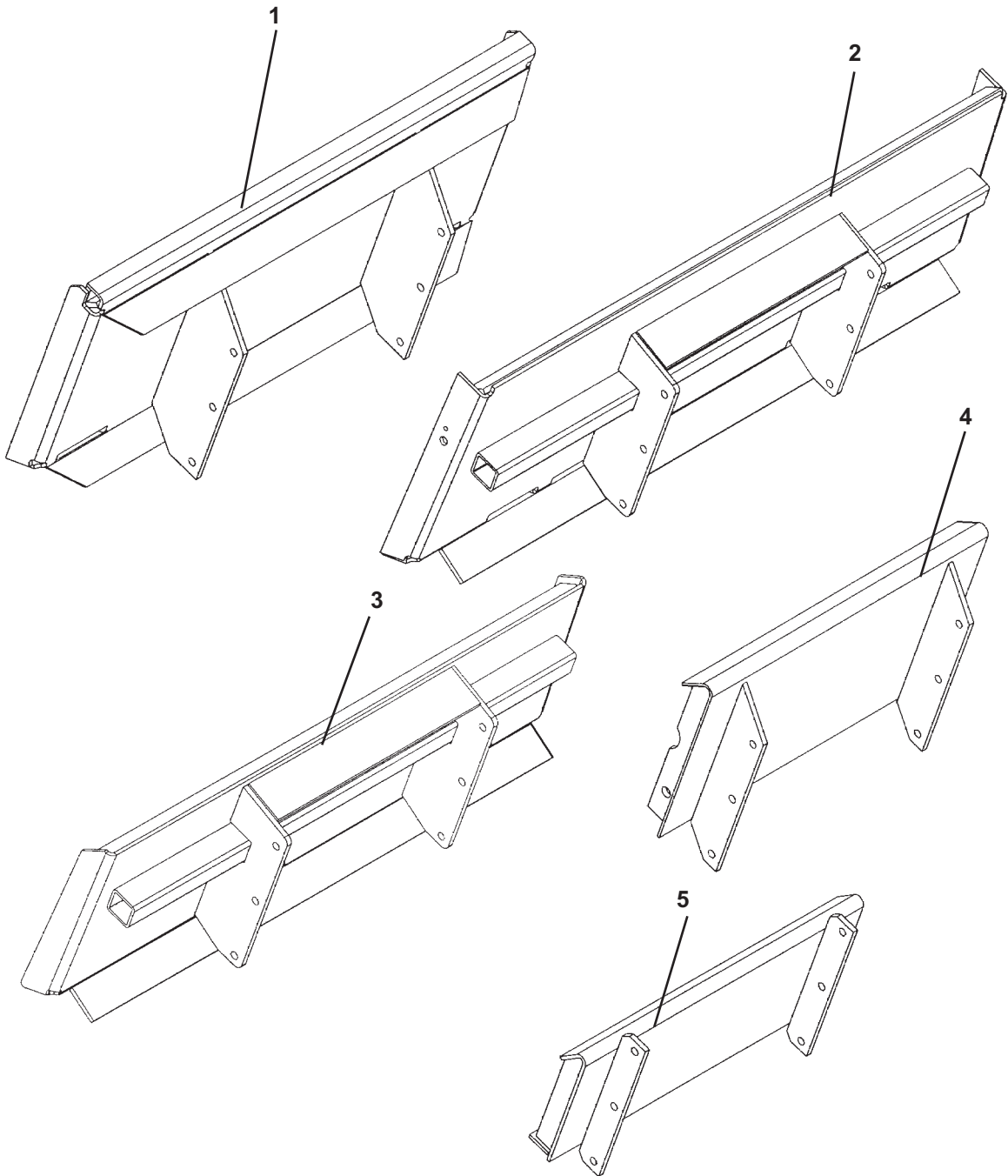

MOUNTING KIT ASSEMBLIES

<u>ITEM</u>	<u>REQ'D</u>	<u>PART NO.</u>	<u>DESCRIPTION</u>
1	*	25706	Mounting Bracket - Bobcat MT50 (Mounting Kit #25689 includes Hoses and Couplers)
2	*	25623	Mounting Bracket - Universal Skid-Steer (Mounting Kit #25696 includes Hoses and Couplers)
3	*	104743	Mounting Bracket - ASV RC30/ Polaris ASL300 (Mounting Kit #25744 includes Hoses and Couplers)
4	*	25844	Mounting Bracket - NH LS120 & LS125 (Mounting Kit #25891 includes Hoses and Couplers)
5	*	25600	Mounting Bracket - Universal Mini Skid-Steer (Mounting Kit #25608 includes Hoses and Couplers)

POWER AND RETURN HYDRAULIC CIRCUIT

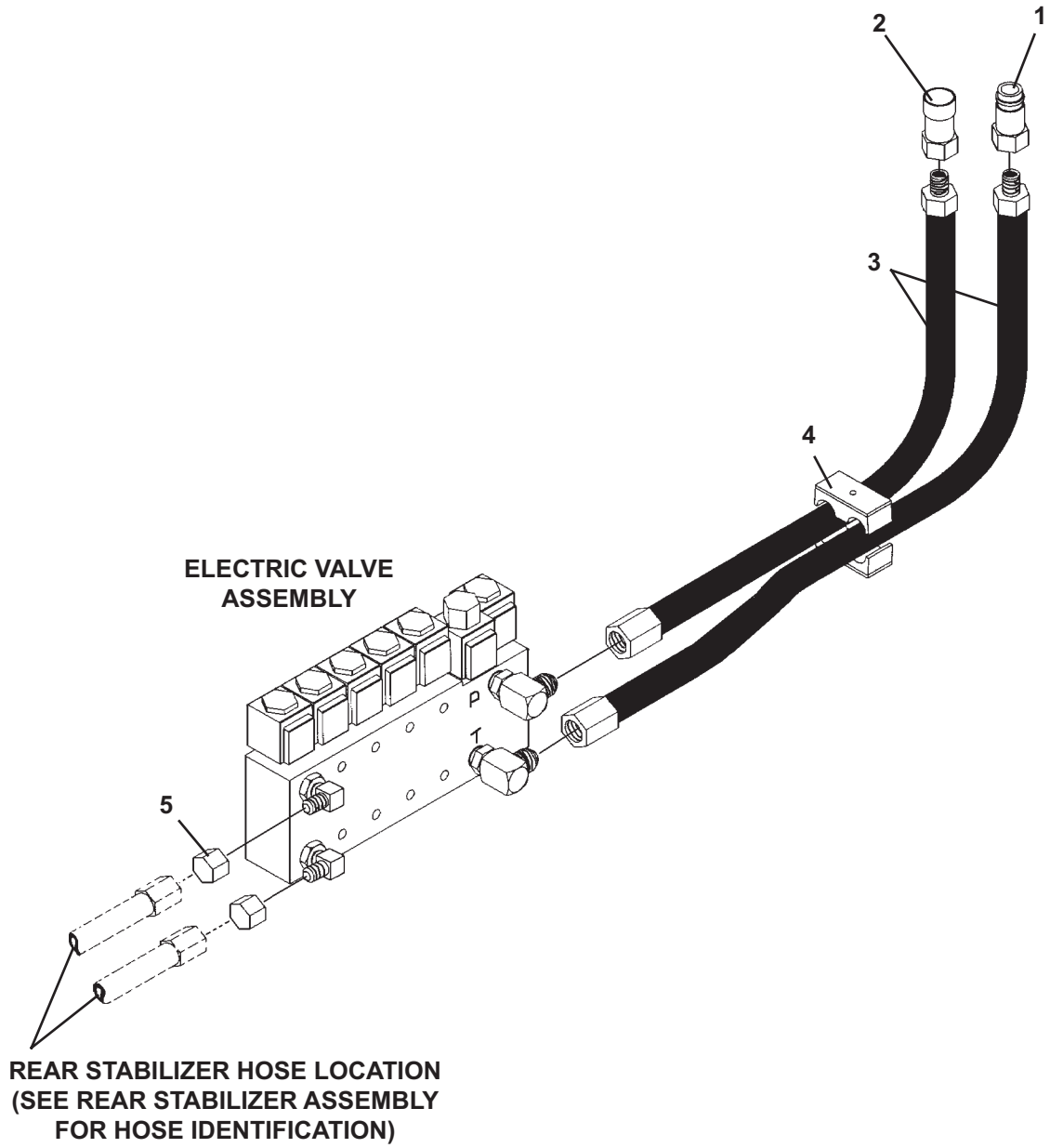

POWER AND RETURN HYDRAULIC CIRCUIT

<u>ITEM</u>	<u>REQ'D</u>	<u>PART NO.</u>	<u>DESCRIPTION</u>
1	*	14176	Male Coupler .50" 8FBo - Flat Face Style
	*	17139	Male Coupler .50" 8FBo - Poppet Style
2	*	14175	Female Coupler .50" 8FBo - Flat Face Style
	*	17140	Female Coupler .50" 8FBo - Poppet Style
3	*	35247	Hose .38" X 60" 8FJX-8MBo-HS
	*	38163	Hose .38" X 76" 8FJX-8MBo-HS
4	1	81358	Hose Clamp
5	2	3285	Plug

* Coupler style and hose length are specific to your loader application. Contact Factory or your local BRADCO dealer for coupler styles or hose lengths not listed above.

BLADE HYDRAULIC CIRCUIT

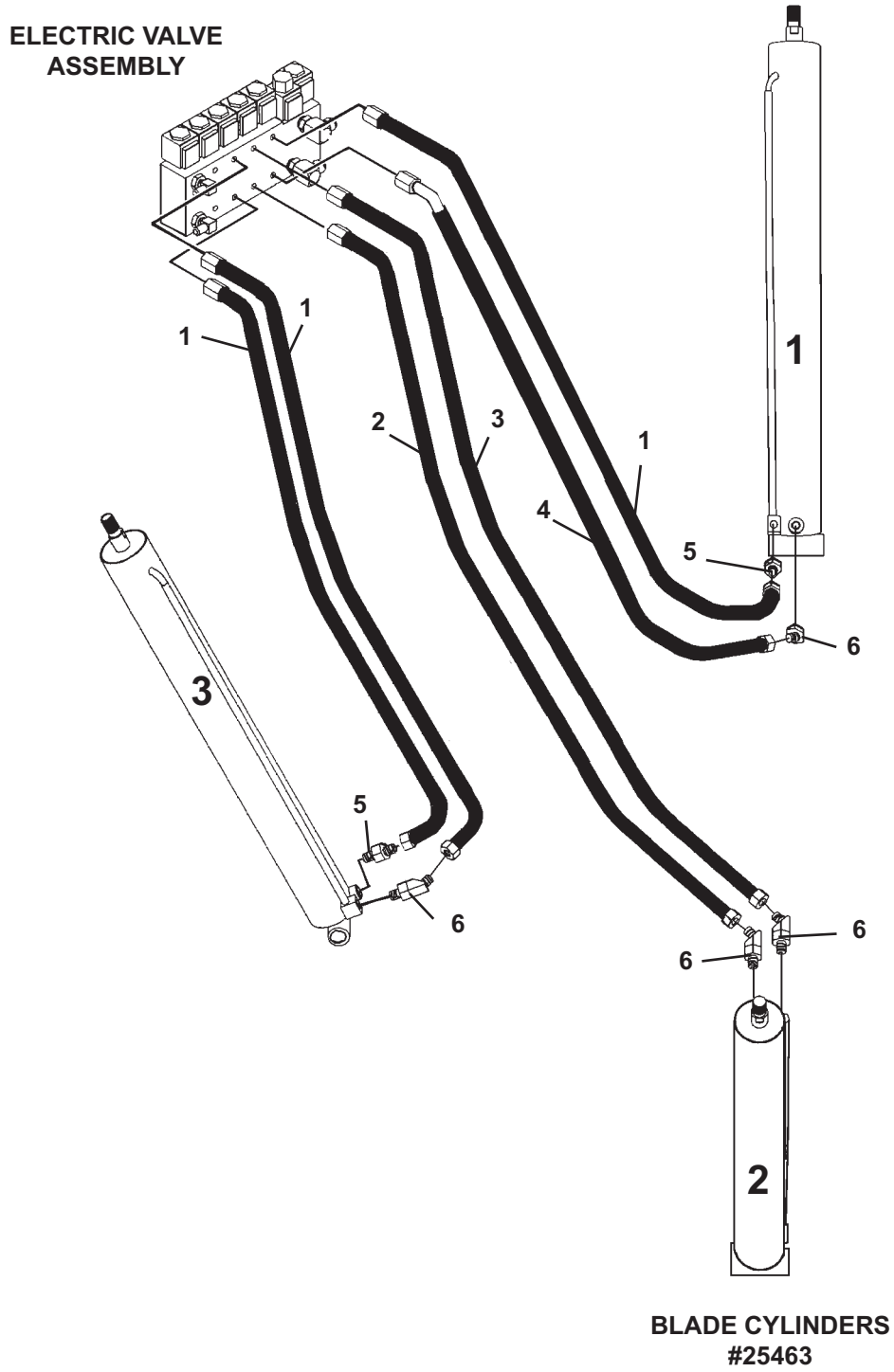

BLADE HYDRAULIC CIRCUIT

<u>ITEM</u>	<u>REQ'D</u>	<u>PART NO.</u>	<u>DESCRIPTION</u>
1	3	38399	Hose .25" X 17" 6FJX - .38 WEO
2	1	38403	Hose .25" X 27" 6FJX - .38 WEO
3	1	38400	Hose .25" X 28" 6FJX - .38 WEO
4	1	38398	Hose .25" X 17" 6FJX - .38 WEO 45°
5	2	3457	Straight Adaper
6	4	30313	45° Elbow

GATE HYDRAULIC CIRCUIT

**ELECTRIC VALVE
ASSEMBLY**

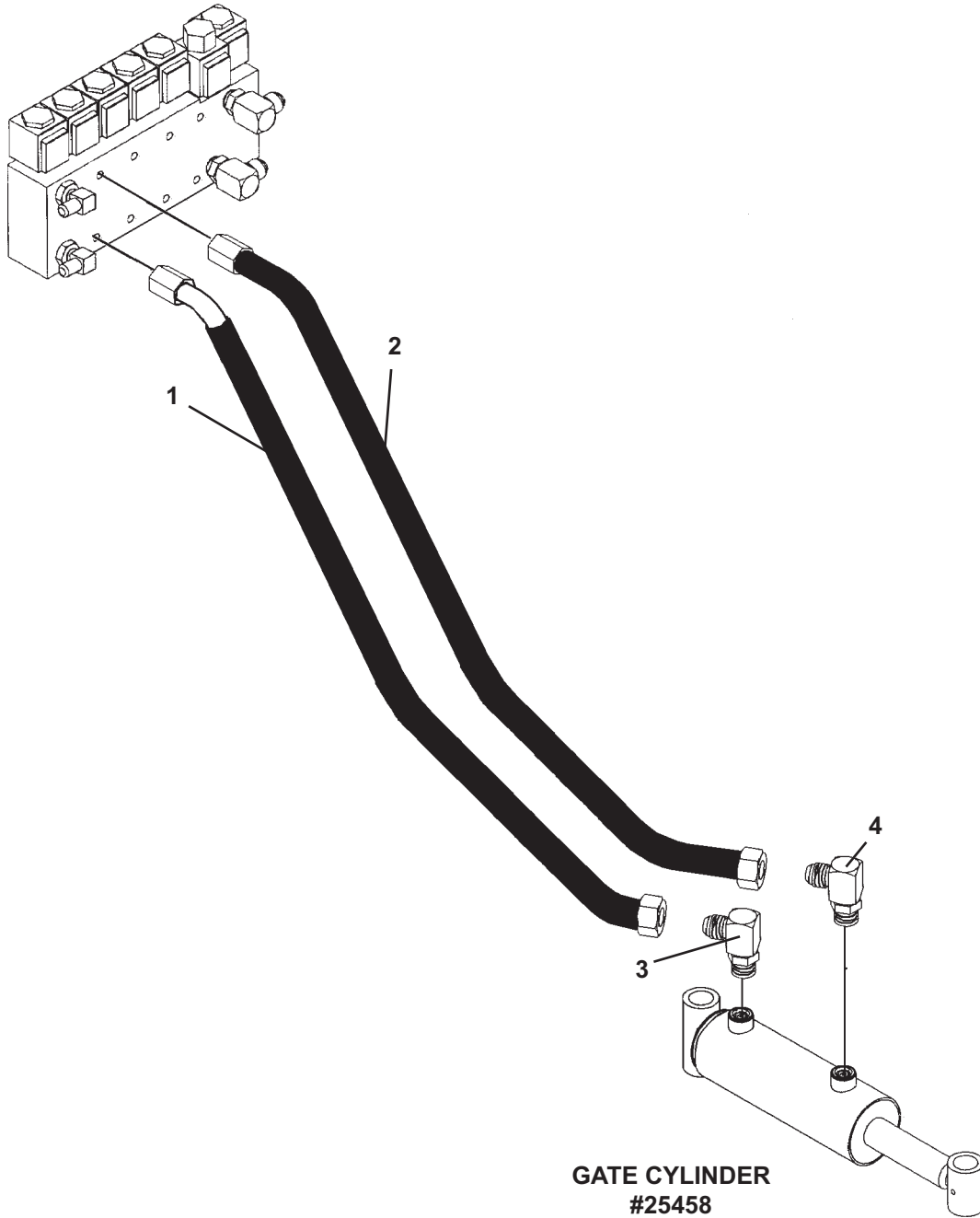

GATE HYDRAULIC CIRCUIT

<u>ITEM</u>	<u>REQ'D</u>	<u>PART NO.</u>	<u>DESCRIPTION</u>
1	1	38401	Hose .25" X 20" 6FJX - .38 WEO 45°
2	1	38402	Hose .25" X 22" 6FJX - .38 WEO
3	1	30140	90° Elbow - Long 6MBo-6MJ
4	1	14067	90° Elbow - 6MBo-6MJ w/.027 Orifice

CYLINDER ASSEMBLY

ASSEMBLY #25458

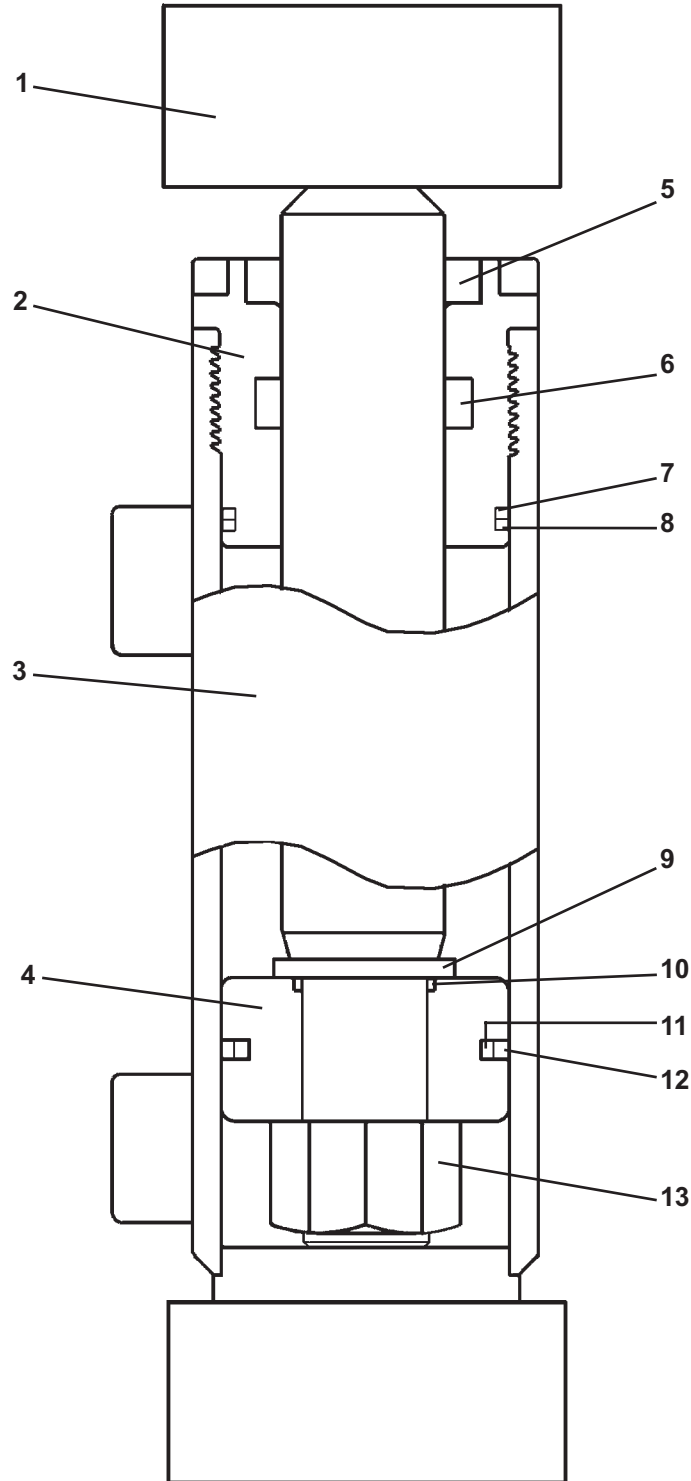

CYLINDER ASSEMBLY

ASSEMBLY #25458

<u>ITEM</u>	<u>REQ'D</u>	<u>PART NO.</u>	<u>DESCRIPTION</u>
1	1	25460	Cylinder Rod
2	1	89527	Cylinder Gland
3	1	25459	Cylinder Tube
4	1	6992	Piston
5	1	4981*	Rod Wiper
6	1	45262*	PolyPak Seal
7	1	4634*	Back-Up Washer
8	1	4633*	O-Ring
9	1	52644	Washer
10	1	4635*	O-Ring
11	1	4637*	O-Ring
12	1	4636*	Piston Ring
13	1	1482	Hex Nut

NOTE: Seal Kit #45581 includes all parts marked with as asterisk (*). Parts are not sold separately.

10192 2-28-06

CYLINDER ASSEMBLY

ASSEMBLY #25463

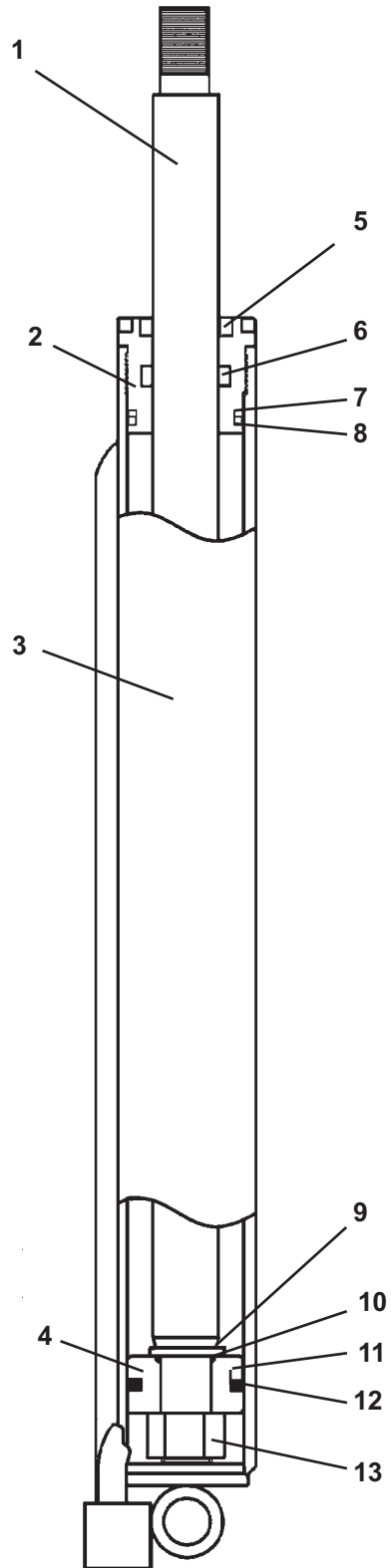

CYLINDER ASSEMBLY

ASSEMBLY #25463

<u>ITEM</u>	<u>REQ'D</u>	<u>PART NO.</u>	<u>DESCRIPTION</u>
1	1	25465	Cylinder Rod
2	1	89527	Cylinder Gland
3	1	25464	Cylinder Tube
4	1	6992	Piston
5	1	4981*	Rod Wiper
6	1	45262*	PolyPak Seal
7	1	4634*	Back-Up Washer
8	1	4633*	O-Ring
9	1	52644	Washer
10	1	4635*	O-Ring
11	1	4637*	O-Ring
12	1	4636*	Piston Ring
13	1	1482	Hex Nut

NOTE: Seal Kit #45581 includes all parts marked with as asterisk (*). Parts are not sold separately.

10190 2-28-06

ELECTRICAL VALVE ASSEMBLY

ASSEMBLY #25804

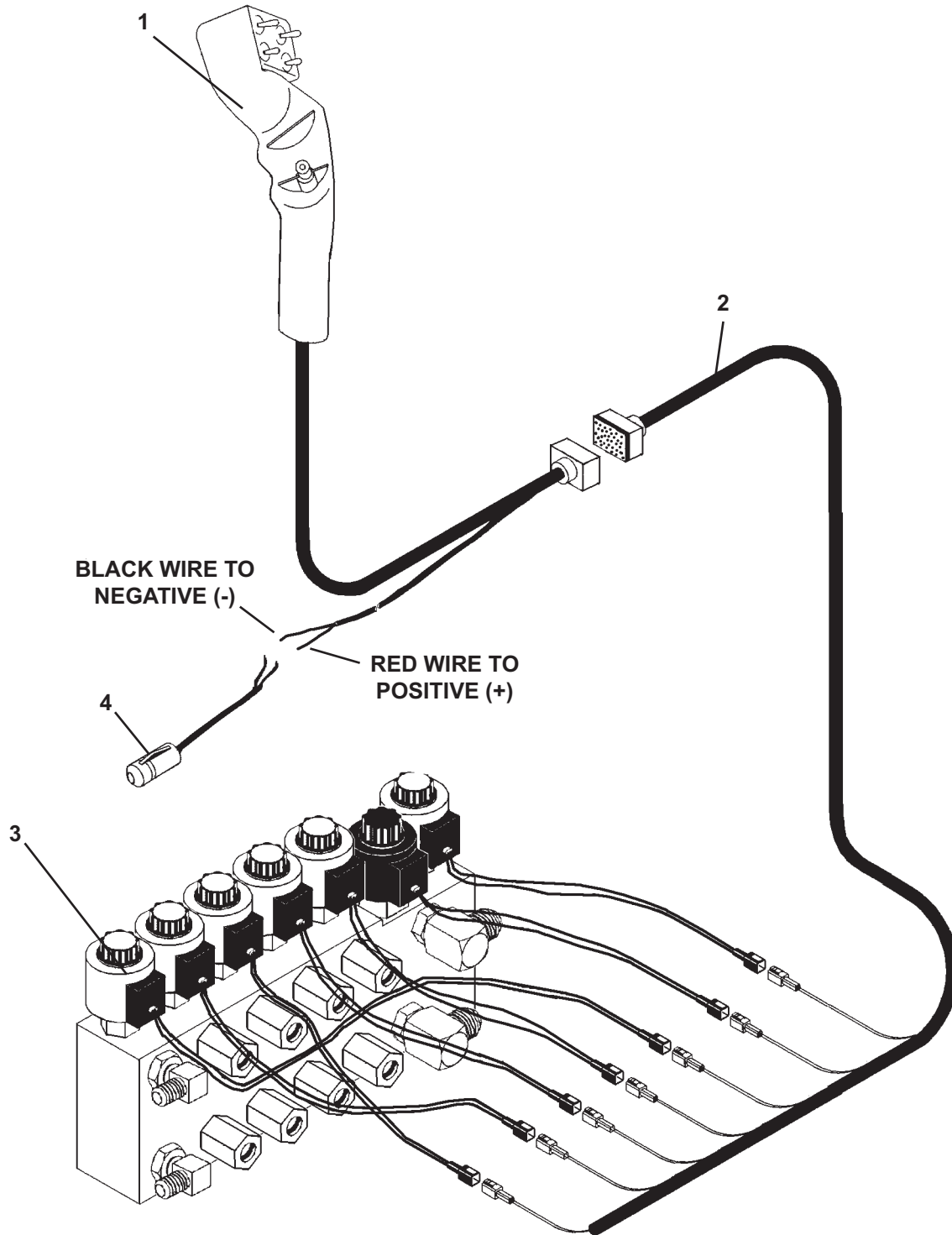

ELECTRICAL VALVE ASSEMBLY

ASSEMBLY #25804

<u>ITEM</u>	<u>REQ'D</u>	<u>PART NO.</u>	<u>DESCRIPTION</u>
1	1	25894	Joystick Assembly Includes Power Cord, Connector, Joystick and Magnetic Storage Bracket
2	1	25893	Wire Harness Assembly Includes Power Cord and Connector
3	1	25892	Valve Assembly Includes Five Circuit Valve with #6 O'Ring Ports, 12 GPM Bi-Directional Unloader One 2-Position, 4-Way Reverser Valve Eight port Adaptors Four 90° Elbow And Deutsch Connectors on Coils
4	-	07-10026	Optional Power Plug Adapter (Cigarette Lighter)

10500 2-28-06

VALVE ASSEMBLY

ASSEMBLY #25892

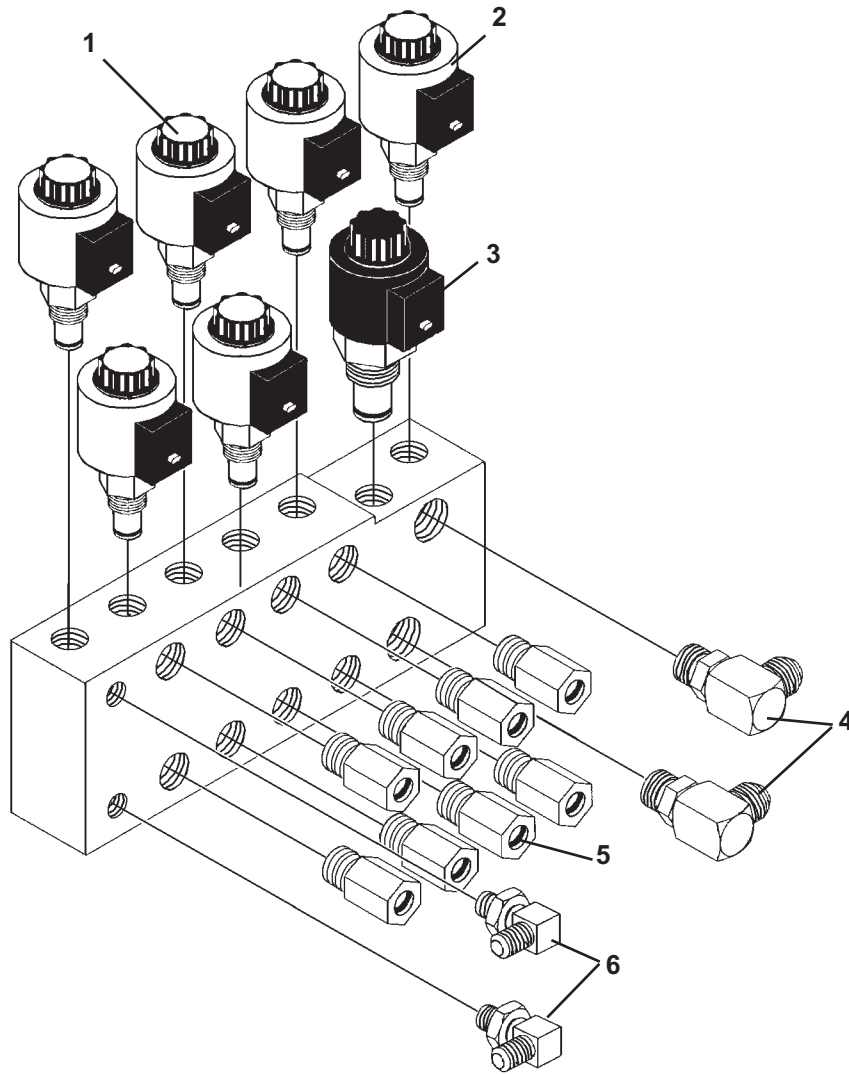

HYDRAULIC SCHEMATIC

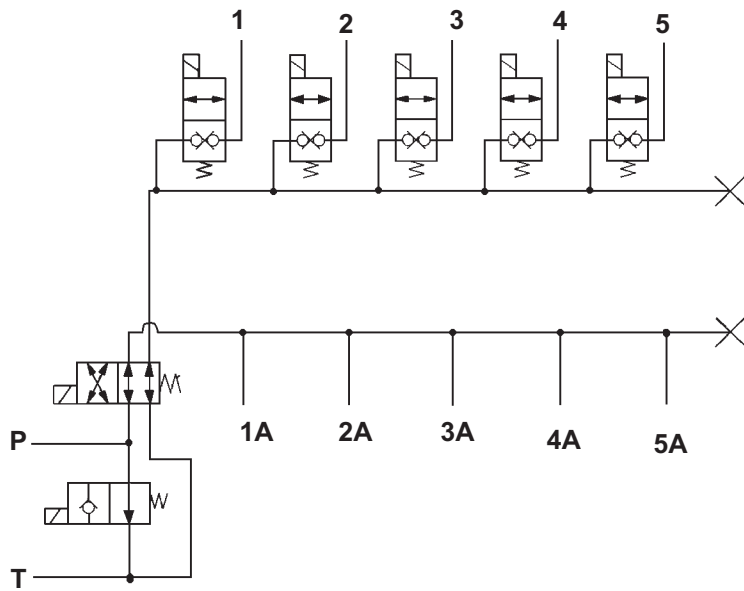

VALVE ASSEMBLY

ASSEMBLY #25892

<u>ITEM</u>	<u>REQ'D</u>	<u>PART NO.</u>	<u>DESCRIPTION</u>
1	5	45865	Circuit Control Spool Assembly
	5	45954	Coil Assembly
2	1	45955	Circuit Flow Reverse Spool Assembly
	1	45954	Coil Assembly
3	1	45956	Unloader Spool Assembly
	1	45954	Coil Assembly
4	2	3104	90° Elbow
5	8	30348	Adapter
6	2	3434	90° Elbow

FUNCTION	WIRE COLOR
REAR STABILIZER	VIOLET
GATE	ORANGE
BLADE 3	WHITE
BLADE 2	BLUE
BLADE 1	BROWN
FLOW REVERSER	GREEN
UNLOADER	YELLOW

SOLENOID VALVES

REPLACEMENT PARTS

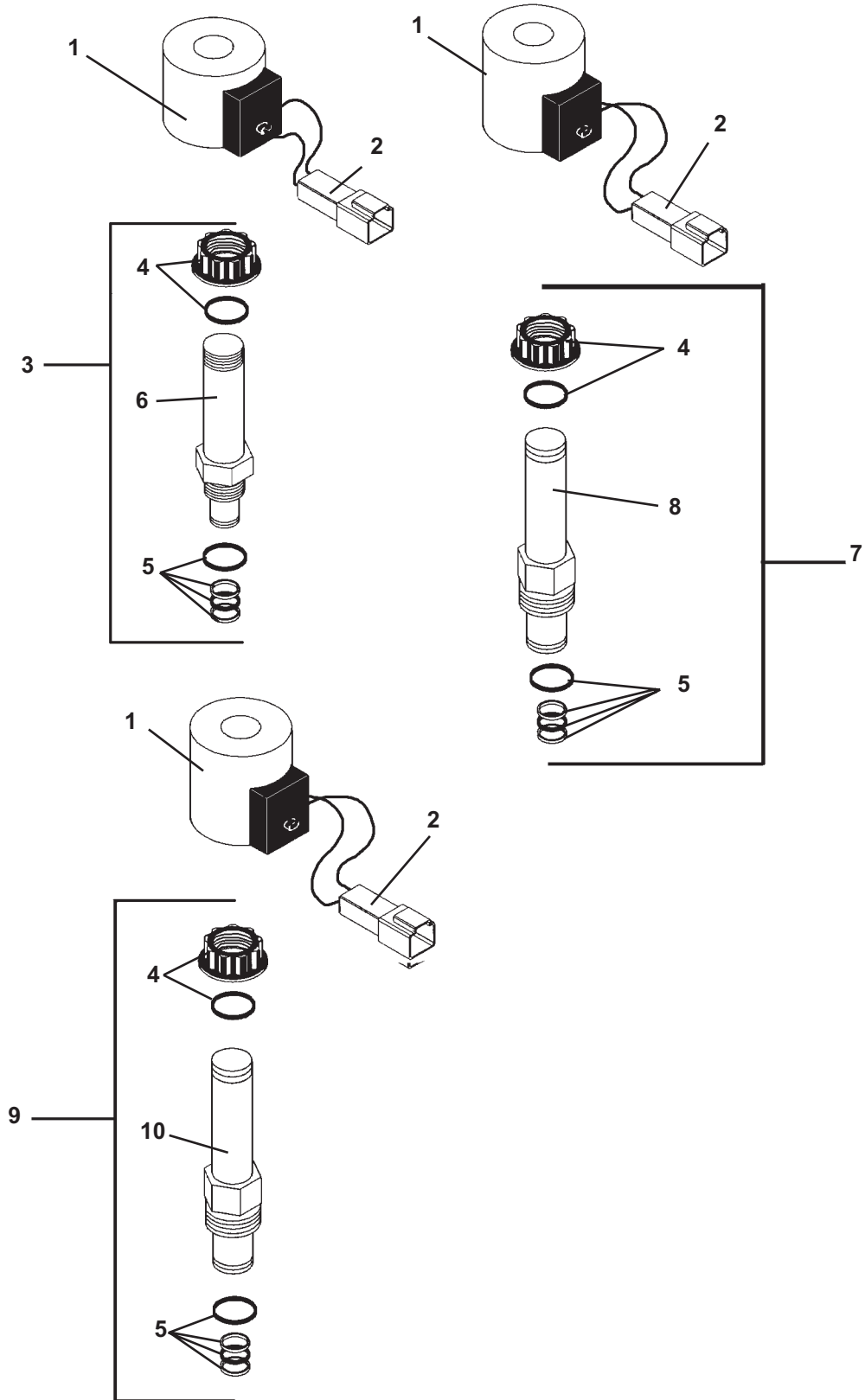

SOLENOID VALVES

REPLACEMENT PARTS

<u>ITEM</u>	<u>REQ'D</u>	<u>PART NO.</u>	<u>DESCRIPTION</u>
1	7	45954	Coil (Includes #2)
2	7	25550	Wire Terminal Connector
3	5	45865	Circuit Control Spool Assembly (Includes items #4, #5 & #6)
4	7	45869	Nut Assembly (Includes O'Ring)
5	1	-----	Spool (Not Sold Separately)
6	7	45874	Replacement Seal Kit
7	1	45955	Reverse Valve Spool Assembly (Includes items #4, #8 & #5)
8	1	-----	Spool (Not Sold Separately)
9	1	45956	Unloader Spool Assembly (Includes items #4, #10 & #5)
10	1	-----	Spool (Not Sold Separately)

JOYSTICK ASSEMBLY

WIRING SCHEMATIC FOR ASSEMBLY #25894

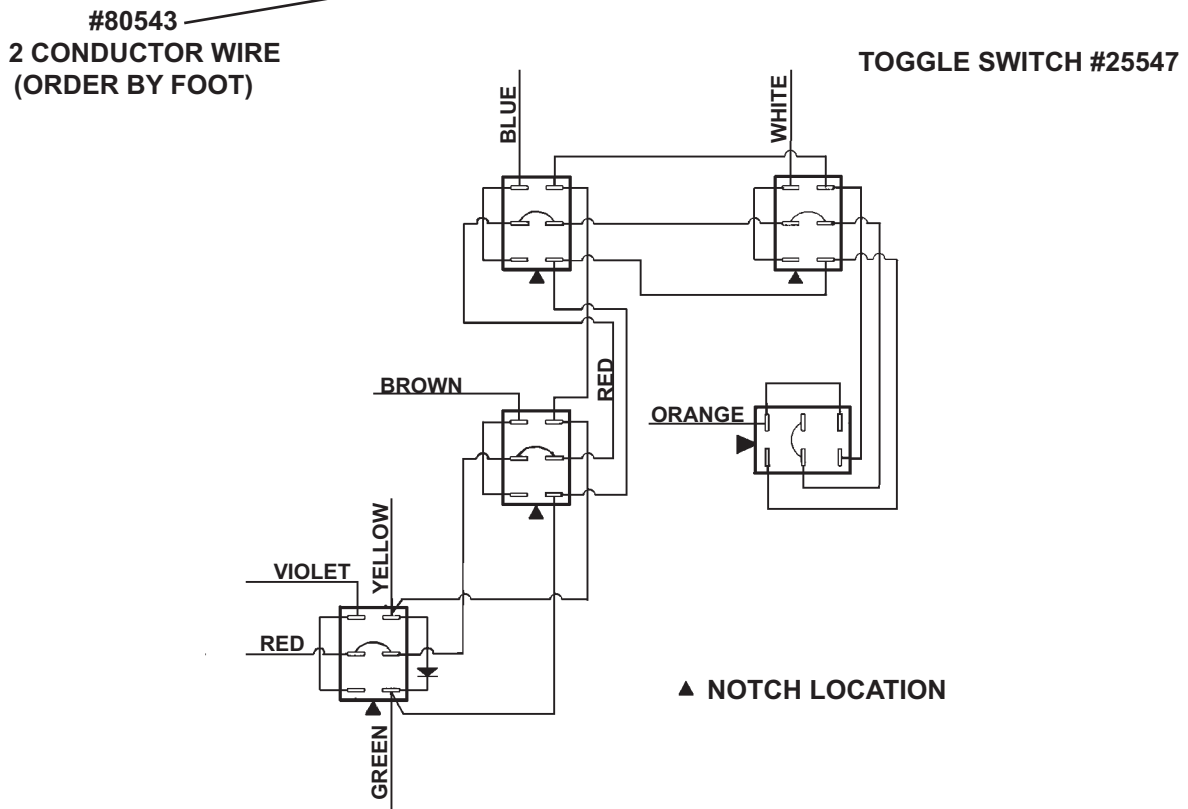
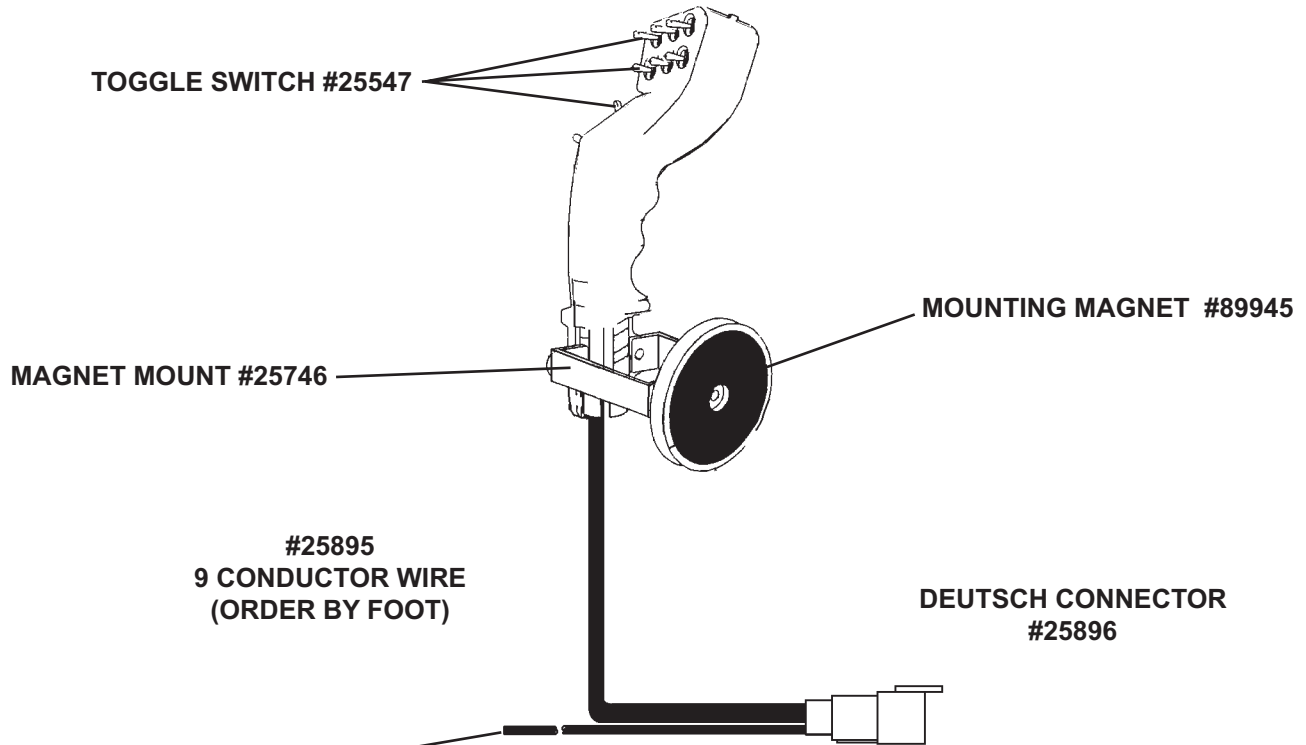

WIRE HARNESS ASSEMBLY

WIRING SCHEMATIC FOR ASSEMBLY #25893

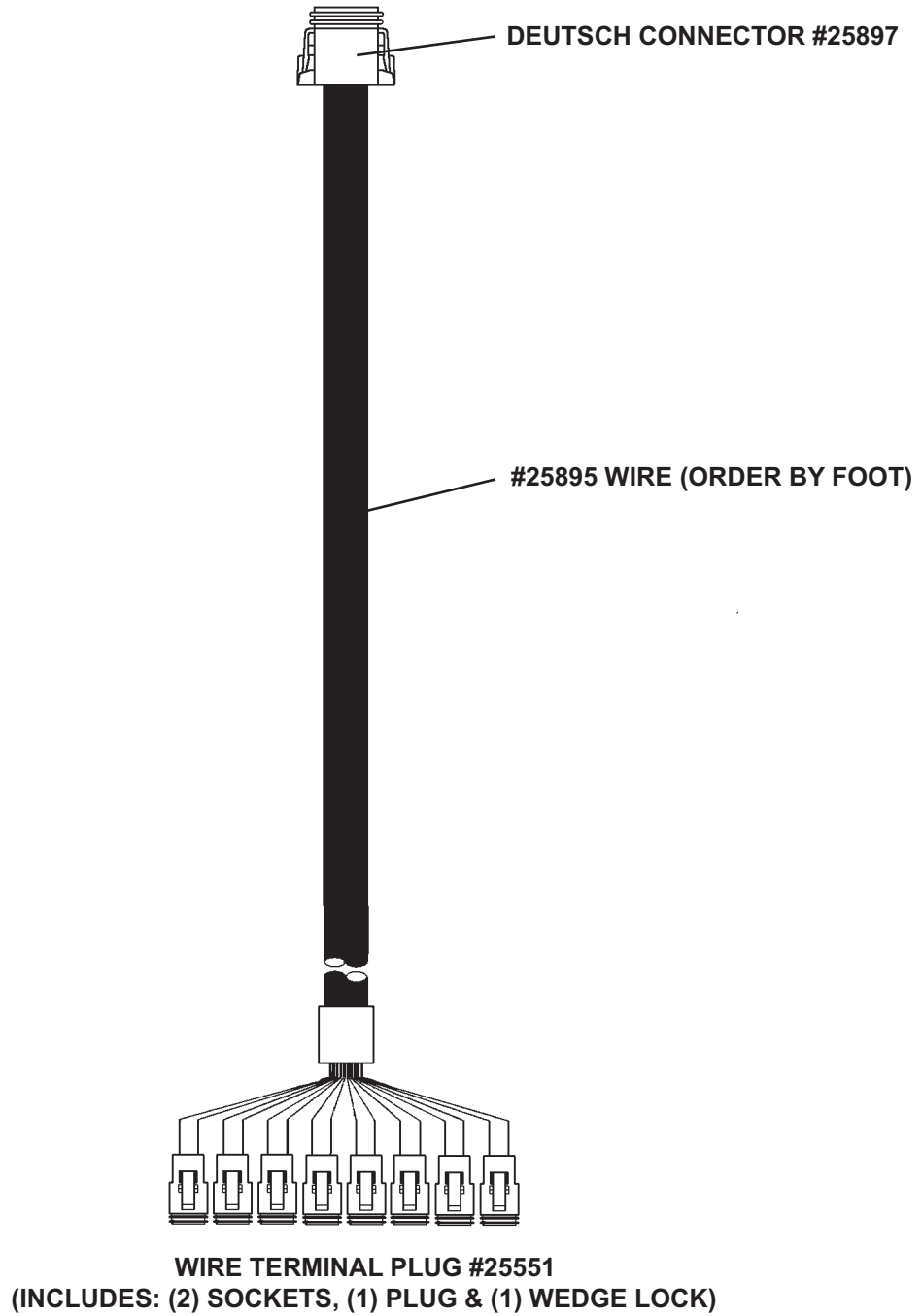

WIRING SCHEMATIC

DEUTSCH CONNECTORS

PIN OUT DETAIL

