



OPERATOR'S AND PARTS MANUAL

HP400/HP450/HP600/HP750/HP1000 COLD PLANERS FOR SKID-STEER LOADERS



PALADIN LIGHT CONSTRUCTION



SERIAL NUMBER: _____

MODEL NUMBER: _____

Manual Number: OM666

Part Number: 75566

Rev. 4

TABLE OF CONTENTS

PREFACE	3
SAFETY PRECAUTIONS	
SAFETY STATEMENTS	5
GENERAL SAFETY PRECAUTIONS	5-7
EQUIPMENT SAFETY PRECAUTIONS	8
DECALS	
DECAL PLACEMENT	9
DECALS	10-11
PRE-OPERATION	12-13
INSTALLATION	14-15
OPERATING INSTRUCTIONS	
GENERAL OPERATING INSTRUCTIONS	16-17
SPECIAL APPLICATIONS	18-19
Large Area	
Milling Around Manholes	
Deep Cuts	
Milling Taper Cuts	
MAINTENANCE AND SERVICE	
LUBRICATION	20
ROUTINE MAINTENANCE	21
PICK REPLACEMENT	22
CHANGING THE DRUM	23
CHANGING THE PLANETARY	23-24
CHANGING THE HYDRAULIC MOTOR	24
CYLINDER SEAL REPLACEMENT	25-26
TROUBLESHOOTING	27-28
SPECIFICATIONS	
BOLT TORQUE SPECIFICATIONS	29
COLD PLANER SPECIFICATIONS	30
LIMITED WARRANTY	31
PARTS	
PLANER ASSEMBLIES	32-37
DRUM AND PICK OPTIONS	38-39
WHEEL ASSEMBLY	40-41
HYDRAULIC ASSEMBLY	42-43
HOSE KIT #38168 - 16" & 18" PLANERS (HP400 / HP450)	44-45
HOSE KIT #38169 - 24" PLANER (HP600)	46-47
HOSE KIT #38170 - 30" PLANER (HP750)	48-49
HOSE KIT #38308 - 40" PLANER (HP1000)	50-51
WATER KIT #19216	52-53
WATER KIT #103031	54-55
CYLINDER ASSEMBLY #101540	56-57
CYLINDER ASSEMBLY #83530	58-59
CYLINDER ASSEMBLY #89520	60-61
CYLINDER ASSEMBLY #89535	62-63

PREFACE

GENERAL COMMENTS

Congratulations on the purchase of your new BRADCO product! This product was carefully designed and manufactured to give you many years of dependable service. Only minor maintenance (such as cleaning and lubricating) is required to keep it in top working condition. Be sure to observe all maintenance procedures and safety precautions in this manual and on any safety decals located on the product and on any equipment on which the attachment is mounted.

This manual has been designed to help you do a better, safer job. Read this manual carefully and become familiar with its contents.

WARNING!  Never let anyone operate this unit without reading the "Safety Precautions" and "Operating Instructions" sections of this manual. Always choose hard, level ground to park the vehicle on and set the brake so the unit cannot roll.

Unless noted otherwise, right and left sides are determined from the operator's control position when facing the attachment.

NOTE: The illustrations and data used in this manual were current (according to the information available to us) at the time of printing, however, we reserve the right to redesign and change the attachment as may be necessary without notification.

BEFORE OPERATION

The primary responsibility for safety with this equipment falls to the operator. Make sure the equipment is operated only by trained individuals that have read and understand this manual. If there is any portion of this manual or function you do not understand, contact your local authorized dealer or the manufacturer.

SAFETY ALERT SYMBOL



This is the "Safety Alert Symbol" used by this industry. This symbol is used to warn of possible injury. Be sure to read all warnings carefully. They are included for your safety and for the safety of others working with you.

SERVICE

When servicing your product, remember to use only manufacturer replacement parts. Substitute parts may not meet the standards required for safe, dependable operation.

To facilitate parts ordering, record the model and serial number of your unit in the space provided on the cover of this manual. This information may be obtained from the identification plate located on the product.

The parts department needs this information to insure that you receive the correct parts for your specific model.

SAFETY STATEMENTS



THIS SYMBOL BY ITSELF OR WITH A WARNING WORD THROUGHOUT THIS MANUAL IS USED TO CALL YOUR ATTENTION TO INSTRUCTIONS INVOLVING YOUR PERSONAL SAFETY OR THE SAFETY OF OTHERS. FAILURE TO FOLLOW THESE INSTRUCTIONS CAN RESULT IN INJURY OR DEATH.



DANGER

THIS SIGNAL WORD IS USED WHERE SERIOUS INJURY OR DEATH WILL RESULT IF THE INSTRUCTIONS ARE NOT FOLLOWED PROPERLY.



WARNING

THIS SIGNAL WORD IS USED WHERE SERIOUS INJURY OR DEATH COULD RESULT IF THE INSTRUCTIONS ARE NOT FOLLOWED PROPERLY.



CAUTION

THIS SIGNAL WORD IS USED WHERE MINOR INJURY COULD RESULT IF THE INSTRUCTIONS ARE NOT FOLLOWED PROPERLY.

NOTICE

NOTICE INDICATES A PROPERTY DAMAGE MESSAGE.

GENERAL SAFETY PRECAUTIONS

WARNING!

READ MANUAL PRIOR TO INSTALLATION



Improper installation, operation, or maintenance of this equipment could result in serious injury or death. Operators and maintenance personnel should read this manual, as well as all manuals related to this equipment and the prime mover thoroughly before beginning installation, operation, or maintenance. **FOLLOW ALL SAFETY INSTRUCTIONS IN THIS MANUAL AND THE PRIME MOVER'S MANUAL(S).**



READ AND UNDERSTAND ALL SAFETY STATEMENTS

Read all safety decals and safety statements in all manuals prior to operating or working on this equipment. Know and obey all OSHA regulations, local laws, and other professional guidelines for your operation. Know and follow good work practices when assembling, maintaining, repairing, mounting, removing, or operating this equipment.



KNOW YOUR EQUIPMENT

Know your equipment's capabilities, dimensions, and operations before operating. Visually inspect your equipment before you start, and never operate equipment that is not in proper working order with all safety devices intact. Check all hardware to ensure it is tight. Make certain that all locking pins, latches, and connection devices are properly installed and secured. Remove and replace any damaged, fatigued, or excessively worn parts. Make certain all safety decals are in place and are legible. Keep decals clean, and replace them if they become worn or hard to read.

GENERAL SAFETY PRECAUTIONS

WARNING!



PROTECT AGAINST FLYING DEBRIS

Always wear proper safety glasses, goggles, or a face shield when driving pins in or out, or when any operation causes dust, flying debris, or any other hazardous material.

WARNING!



LOWER OR SUPPORT RAISED EQUIPMENT

Do not work under raised booms without supporting them. Do not use support material made of concrete blocks, logs, buckets, barrels, or any other material that could suddenly collapse or shift positions. Make sure support material is solid, not decayed, warped, twisted, or tapered. Lower booms to ground level or on blocks. Lower booms and attachments to the ground before leaving the cab or operator's station.

WARNING!



USE CARE WITH HYDRAULIC FLUID PRESSURE

Hydraulic fluid under pressure can penetrate the skin and cause serious injury or death. Hydraulic leaks under pressure may not be visible. Before connecting or disconnecting hydraulic hoses, read your prime mover's operator's manual for detailed instructions on connecting and disconnecting hydraulic hoses or fittings.

- Keep unprotected body parts, such as face, eyes, and arms as far away as possible from a suspected leak. Flesh injected with hydraulic fluid may develop gangrene or other permanent disabilities.
- If injured by injected fluid, see a doctor at once. If your doctor is not familiar with this type of injury, ask him to research it immediately to determine proper treatment.
- Wear safety glasses, protective clothing, and use a piece of cardboard or wood when searching for hydraulic leaks. **DO NOT USE YOUR HANDS!** **SEE ILLUSTRATION.**

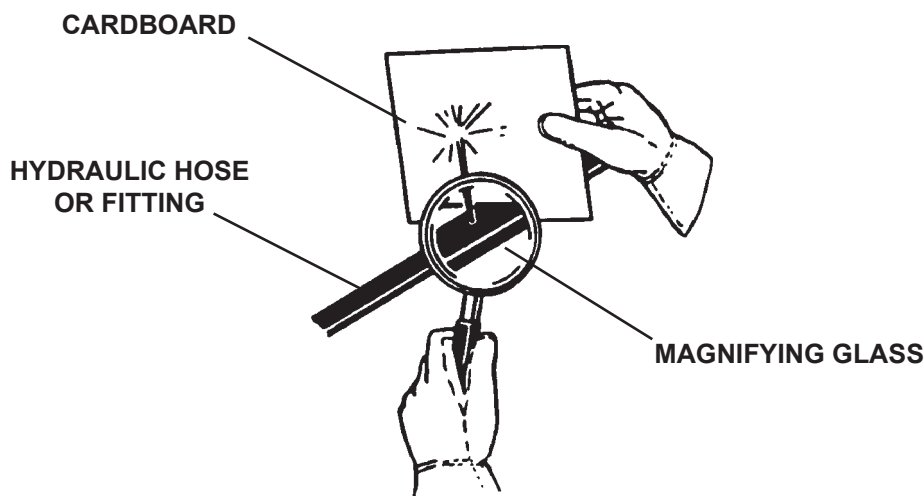

GENERAL SAFETY PRECAUTIONS

WARNING!



DO NOT MODIFY MACHINE OR ATTACHMENTS

Modifications may weaken the integrity of the attachment and may impair the function, safety, life, and performance of the attachment. When making repairs, use only the manufacturer's genuine parts, following authorized instructions. Other parts may be substandard in fit and quality. Never modify any ROPS (Roll Over Protection Structure) or FOPS (Falling Object Protective Structure) equipment or device. Any modifications must be authorized in writing by the manufacturer.

WARNING!



SAFELY MAINTAIN AND REPAIR EQUIPMENT

- Do not wear loose clothing or any accessories that can catch in moving parts. If you have long hair, cover or secure it so that it does not become entangled in the equipment.
- Work on a level surface in a well-lit area.
- Use properly grounded electrical outlets and tools.
- Use the correct tools for the job at hand. Make sure they are in good condition for the task required.
- Wear the protective equipment specified by the tool manufacturer.



SAFELY OPERATE EQUIPMENT

Do not operate equipment until you are completely trained by a qualified operator in how to use the controls, know its capabilities, dimensions, and all safety requirements. See your machine's manual for these instructions.

- Keep all step plates, grab bars, pedals, and controls free of dirt, grease, debris, and oil.
- Never allow anyone to be around the equipment when it is operating.
- Do not allow riders on the attachment or the prime mover.
- Do not operate the equipment from anywhere other than the correct operator's position.
- Never leave equipment unattended with the engine running, or with this attachment in a raised position.
- Do not alter or remove any safety feature from the prime mover or this attachment.
- Know your work site safety rules as well as traffic rules and flow. When in doubt on any safety issue, contact your supervisor or safety coordinator for an explanation.

EQUIPMENT SAFETY PRECAUTIONS

WARNING!



KNOW WHERE UTILITIES ARE

Observe overhead electrical and other utility lines. Be sure equipment will clear them. When digging, call your local utilities for location of buried utility lines, gas, water, and sewer, as well as any other hazard you may encounter.

WARNING!



EXPOSURE TO RESPIRABLE CRYSTALLINE SILICA DUST ALONG WITH OTHER HAZARDOUS DUSTS MAY CAUSE SERIOUS OR FATAL RESPIRATORY DISEASE.

This attachment is designed to plane (mill) rock, concrete and asphalt, causing high levels of dust. It is recommended to use dust suppression, dust collection and if necessary personal protective equipment during the operation of the planer or of any attachment that may cause high levels of dust.



OPERATING THE PLANER

- Block off work area from bystanders, livestock, etc.
- Operate only from the operator's station.
- Reduce speed when driving over rough terrain, on a slope, or turning, to avoid overturning the vehicle.
- An operator must not use drugs or alcohol, which can change his or her alertness or coordination. An operator taking prescription or over-the-counter drugs should seek medical advice on whether or not he or she can safely operate equipment.
- Before exiting the prime mover, lower the attachment to the ground, turn off the prime mover's engine, remove the key and apply the brakes.
- Be sure all doors, guards and shields are in their proper position and securely attached before operating the planer.



TRANSPORTING THE PLANER

- Travel only with the attachment in a safe transport position to prevent uncontrolled movement. Drive slowly over rough ground and on slopes.
- When driving on public roads use safety lights, reflectors, Slow Moving Vehicle signs etc., to prevent accidents. Check local government regulations that may affect you.
- Do not smoke when refueling the prime mover. Allow room in the gas tank for expansion. Wipe up any spilled fuel. Secure cap tightly when done.



MAINTAINING THE PLANER

- Before performing maintenance, lower the attachment to the ground, turn off the engine, remove the key and apply the brakes.
- Never perform any work on the attachment unless you are authorized and qualified to do so. Always read the operator service manual's before any repair is made. After completing maintenance or repair, check for correct functioning of the attachment. If not functioning properly, always tag "DO NOT OPERATE" until all problems are corrected.
- Worn, damaged, or illegible safety decals must be replaced. New safety decals can be ordered from BRADCO.
- Never make hydraulic repairs while the system is under pressure. Serious personal injury or death could result.
- Never work under a raised attachment.

11047 7-27-07

DECALS

DECAL PLACEMENT

GENERAL INFORMATION

The diagram on this page shows the location of the decals used on the BRADCO Cold Planers. The decals are identified by their part numbers, with reductions of the actual decals located on the following pages. Use this information to order replacements for lost or damaged decals. Be sure to read all decals before operating the attachment. They contain information you need to know for both safety and product longevity.

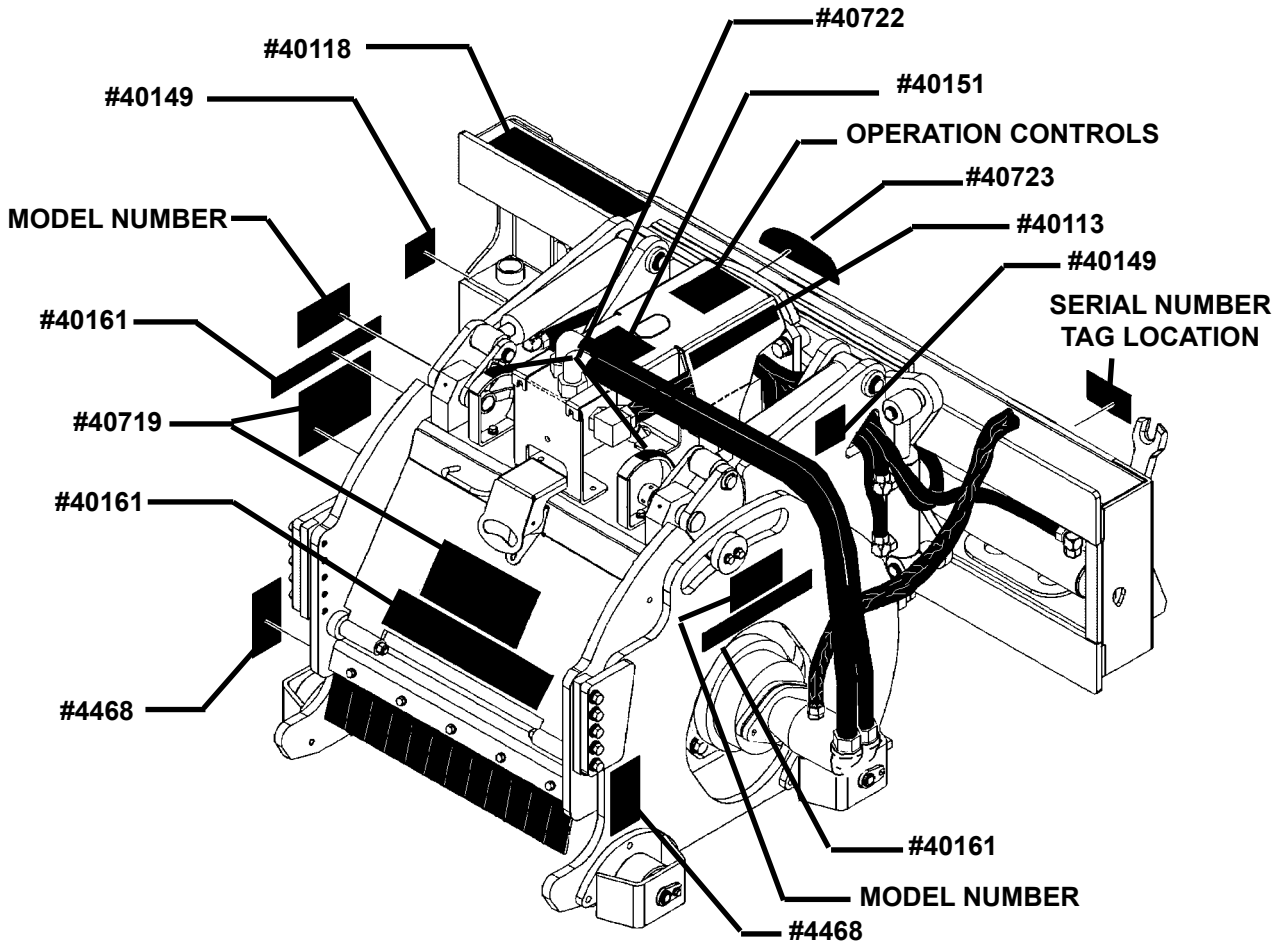

IMPORTANT: Keep all safety signs clean and legible. Replace all missing, illegible, or damaged safety signs. When replacing parts with safety signs attached, the safety signs must also be replaced.

REPLACING SAFETY SIGNS: Clean the area of application with nonflammable solvent, then wash the same area with soap and water. Allow the surface to fully dry. Remove the backing from the safety sign, exposing the adhesive surface. Apply the safety sign to the position shown in the diagram above and smooth out any bubbles.

DECALS



DANGER! PINCH POINTS
PART #40149

STAND CLEAR

STAND CLEAR
PART #40161



WARNING! READ MANUAL
PART #40150



WARNING! HIGH PRESSURE FLUID
PART #40151



DANGER! FLYING DEBRIS
PART #40719



WARNING!
PART #4468

DECALS



BRADCO

BRADCO LOGO
PART #40113

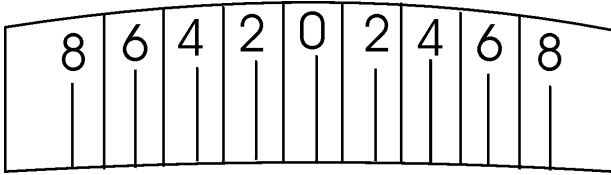

ANGLE INDICATOR
PART #40723

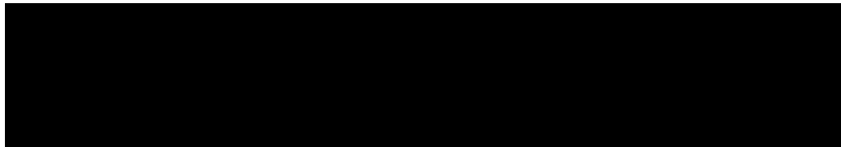

NON-SLIP SURFACE DECAL
PART #40118



DEPTH INDICATOR
PART #40722

HP1000

MODEL NUMBER HP1000 (40" PLANER)
PART #407934

HP750

MODEL NUMBER HP750 (30" PLANER)
PART #40793

HP600

MODEL NUMBER HP600 (24" PLANER)
PART #40792

HP450

MODEL NUMBER HP450 (18" PLANER)
PART #40791

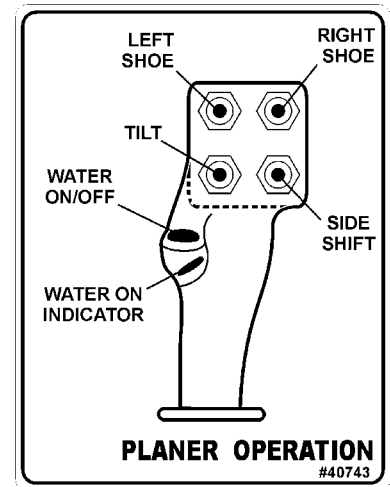

OPERATION CONTROLS
PART #40743

HP400

MODEL NUMBER HP400 (16" PLANER)
PART #40790

PRE-OPERATION

SKID-STEER

The BRADCO 16", 18", 24", 30" and 40" planers are designed for use on high flow skid-steers. Cold planer and skid-steer compatibility is determined by the recommended lifting capacity and hydraulic output of your skid-steer.

WARNING! Do NOT attach or operate any attachment that exceeds the recommended lifting capacity of your skid-steer.



Skid-steers MUST be equipped with optional high flow, auxiliary boom hydraulics, case drain and a multi-function electric control kit to run the cold planer.

WARNING! EXPOSURE TO RESPIRABLE CRYSTALLINE SILICA DUST ALONG WITH OTHER HAZARDOUS DUSTS MAY CAUSE SERIOUS OR FATAL RESPIRATORY DISEASE.



This attachment is designed to plane (mill) rock, concrete and asphalt, causing high levels of dust. It is recommended to use dust suppression, dust collection and if necessary personal protective equipment during the operation of the planer or of any attachment that may cause high levels of dust!

IMPORTANT

Concrete and masonry products contain silica sand. Quartz, which is a form of silica and the most common mineral in the earth's crust, is associated with many types of rock.

Some activities that silica dust may be present in the air include demolition, sweeping, loading, sawing, hammering, drilling or planing of rock, concrete or masonry.

It is recommended to use dust suppression (such as water), dust collection (such as a vacuum) along with personal protective equipment if necessary during the operation of any attachment that may cause high levels of silica dust.

OPTIONS

PLANING OPTIONS	Concrete Picks.....	Contact Dealer
	2.5" (Slot Cutter) Drum.....	#100642
	4.0" (Slot Cutter) Drum.....	#100643
	6.0" (Slot Cutter) Drum.....	#100644
MOTOR OPTIONS	22 GPM to 28 GPM (2.0 CU. IN. BLUE).....	#17776
	29 GPM to 35 GPM (2.5 CU. IN. BLACK).....	#17777
	36 GPM to 44 GPM (3.0 CU. IN. RED).....	#17778

NOTE: 36 GPM to 44 GPM motor is required on the 40" Cold Planers.

PRE-OPERATION

HIGH FLOW COLD PLANERS

NOMENCLATURE

Throughout this manual, reference is made to various attachment components. The purpose of this section is to acquaint you with the various names of these components. This knowledge will be helpful when reading through the manual or when ordering service parts.

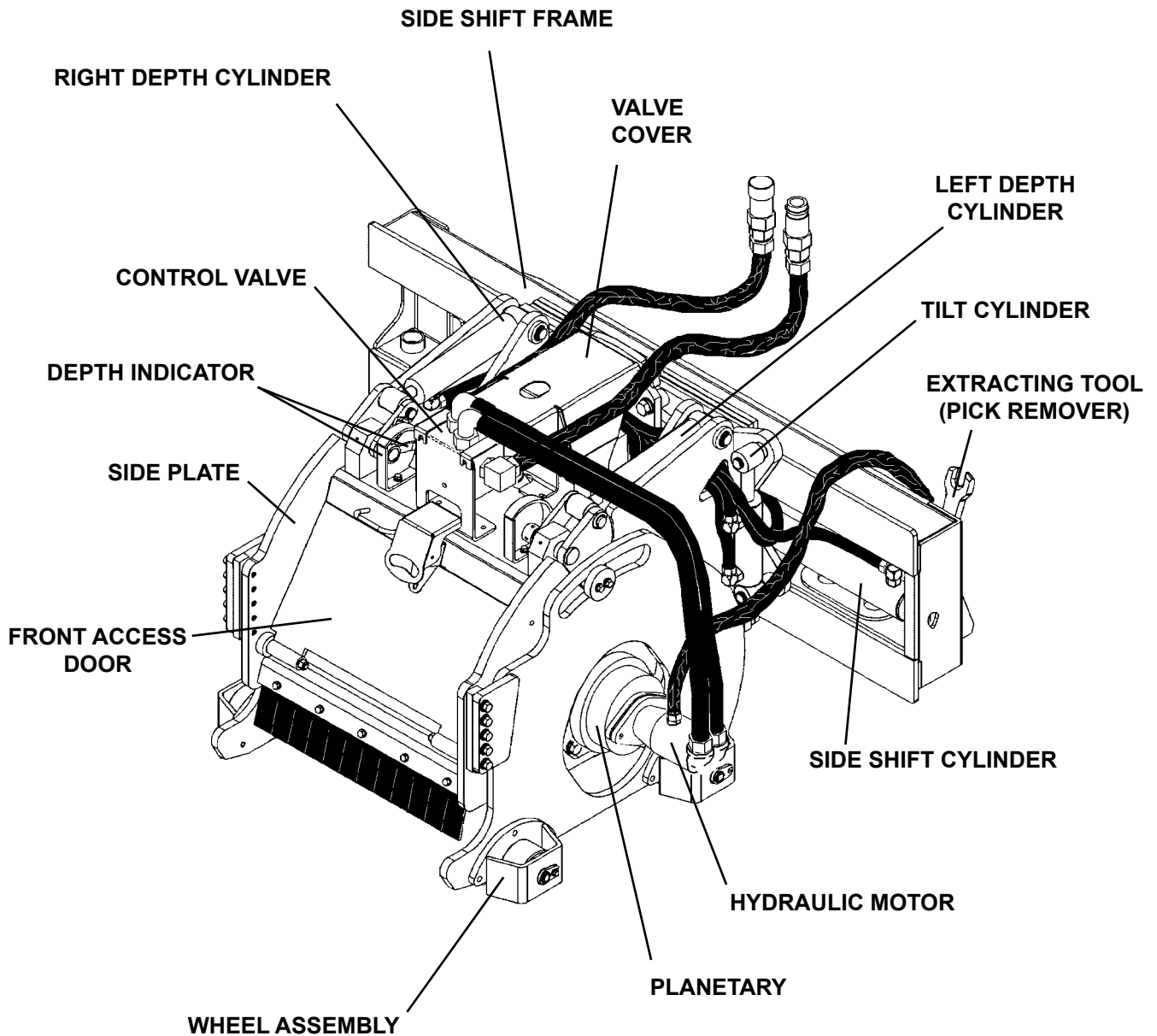

INSTALLATION

GENERAL INFORMATION

The following instructions will help you to mount your planer onto your skid-steer loader. The planer uses the quick-attach system for ease of installation. Therefore, if you know how to attach your loader bucket, attaching the cold planer should prove no problem.

Remember to read all safety warnings, decals and operating instructions before operating the attachment. If there is any portion of this manual that you do not understand, contact your dealer.

WARNING! THE 16", 18", 24", 30" AND 40" PLANERS ARE DESIGNED FOR USE ON HIGH FLOW HYDRAULIC SYSTEMS.



DO NOT ATTACH OR OPERATE ANY ATTACHMENT THAT EXCEEDS THE RECOMMENDED LIFTING CAPACITY OF YOUR SKID-STEER.

INSTALLATION INSTRUCTIONS

1. Remove the shipping banding from around the planer and skid.
2. Remove any attachments from the front of the loader.
3. Following all standard safety practices and the instructions for installing an attachment in your skid-steer operator's manual, install the planer onto your skid-steer.

NOTE: It is important to make sure the locking mechanism on your quick attach is engaged, therefore locking the attachment onto the skid-steer.

4. Lower the unit to the ground and remove the key.
5. Relieve any pressure from the auxiliary hydraulic system. After making sure that there is not any foreign matter on the hydraulic couplers connect the case drain coupler to the case drain on your skid-steer loader. NOTE: The case drain line must be connected first, then the power and return hoses. When disconnecting the hoses, it is recommended to disconnect the case drain line last.
6. Connect the power and return couplers to the high flow auxiliary hydraulic system of your skid-steer loader. Route the hose in such a fashion as to avoid pinching or chafing.

CAUTION! BE SURE CASE DRAIN COUPLER IS COMPLETELY ENGAGED. IMMEDIATE HYDRAULIC MOTOR SEAL FAILURE AND PLANETARY DAMAGE WILL OCCUR IF CASE DRAIN IS NOT SUCCESSFULLY CONNECTED.



7. Connect the electrical wire harness from the cold planer to the auxiliary electrical connector on the front of the skid-steer (if so equipped). If your skid-steer is not equipped with an electrical connector and you are using the BRADCO control handle, connect the wiring harness to the control handle and place the control handle inside of the skid-steer operator's station.

WARNING! Do not operate the cold planer from outside of the skid-steer operator's station.



INSTALLATION

8. Following all standard safety practices, start the skid-steer and run all cylinders through their full cycle to purge any air from the system. Check that all controls function in accordance with the operating control decal.
9. All planers are equipped with a water nozzle kit to adapt them to your existing water line. Install the female coupler supplied to your existing water line coming from the water tank on the skid-steer. Connect the female coupler to the male coupler on the planer water nozzle kit. NOTE: There is an optional cab mounted water kit available through your local dealer.

Your planer is now installed and ready for operation.

DISCONNECT INSTRUCTIONS

1. Center the planer on the sideshift frame.
2. Adjust depth and tilt setting to "0".
3. Set cold planer on a firm level surface.
4. Following Safety Shut Down Procedures; stop the engine and set the parking brake. Relieve any pressure in the hydraulic lines.
5. Disconnect the power and return hoses from the auxiliary hydraulics. Disconnect the case drain line. NOTE: It is recommended to disconnect the case drain line last.
6. Disconnect the electrical wire harness from the auxiliary electrical connector or the BRADCO control handle and after turning the ball valve to the shut off position disconnect the water line at the couplers.
7. Following all standard safety practices and the instructions for disconnecting an attachment in your skid-steer operator's manual, disconnect the planer from your skid-steer allowing the mounting bracket to lower toward the ground as the skid-steer is disengaged.
8. Connect the hydraulic couplers on the attachment together to prevent contaminants from entering the hydraulic system.

OPERATING INSTRUCTIONS

GENERAL INFORMATION

The BRADCO planer attaches to the toolbar/quick-attach mechanism of your skid-steer loader. Due to this arrangement, thorough knowledge of the skid-steer controls is necessary for machine operation. Read and understand your skid-steer operator's manual for information regarding skid-steer operation before attempting to use the planer.

Check the surface to be planed. The standard all purpose picks can be used to mill both asphalt and concrete. There are optional concrete picks that are recommended if the planer is to be used extensively for concrete. These picks do not perform as well when milling asphalt, especially in warmer weather.

Review the job at hand and determine the required depth and tilt of the cut and also the side shift position of the planer. Best performance is obtained when the cold planer is in the center position. Side shift should be used when visibility is a determining factor such as milling around manholes or when milling next to an obstacle such as a building. **NOTE: Although the wheel assemblies are standard, they may be removed when distance is a factor such as milling next to an obstacle or building.**

OPERATING INSTRUCTIONS

1. Clear area of all bystanders.
2. Lift the planer until the drum is off the ground and start planer rotation. (Teeth at the bottom of the drum must be moving in the same forward direction that the planer travels.)

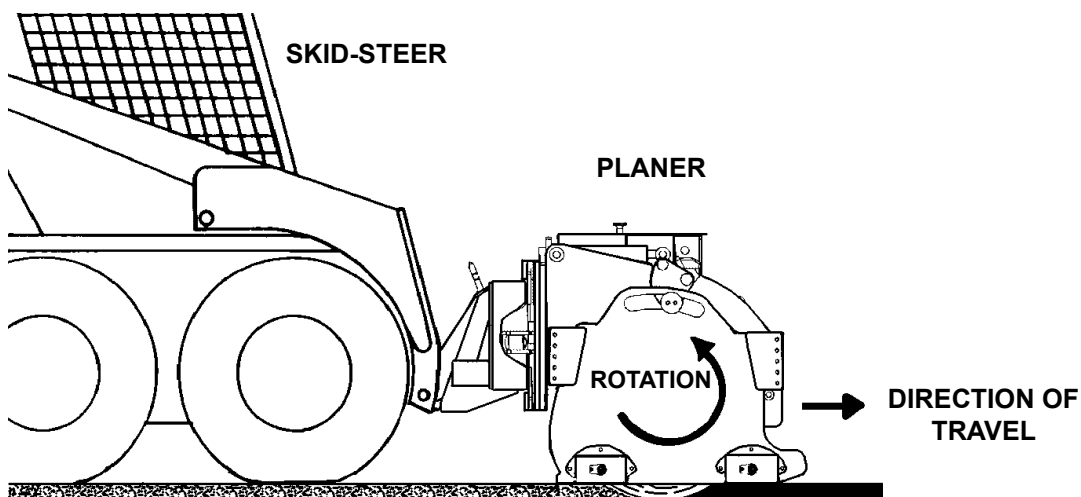

NOTE: Mill only when the skid-steer is traveling forward. Do not operate when traveling in reverse.

OPERATING INSTRUCTIONS

NOTE: Hydraulic cylinders tilt the planer, adjust the depth of both the left and right side of the planer individually, and also shift the planer to the left or right.

3. Increase engine RPM and with the drum turning you can make any necessary adjustments to the side shift. Do not side shift the cold planer during milling operation. Once the desired side shift position has been achieved you are ready to begin. The drum will not cut in a side to side motion. Tilt and Depth control can both be activated during milling.

IMPORTANT: The drum MUST be turning to make any hydraulic adjustment to the planer.

4. Position the planer at the desired starting point. Set the left and right depth gauge to the desired depth mark on the planer. Maximum depth of each cut is determined by the type of material, the horsepower of the skid-steer being used and the size of the planer. It is recommended for maximum performance that you start at approximately .75" to 1" in concrete and 1.50" to 2" in asphalt.
5. With the engine at full RPM and the planer rolled back, lower the loader arms completely down and slowly roll out the planer until the weight of the planer is resting on the rear wheel assemblies. Continue to exert down pressure by rolling the loader forward until the front wheels of the planer are on the ground and the front wheels of the skid-steer are raised approximately 2-3 inches off the planing surface to assure sufficient pressure for stable operation.

NOTE: It is recommended to try a sample cut until the desired depth is achieved.

6. Slowly advance forward.

NOTE: If drum stalls you have been traveling too fast or cutting too deep. Back out of the cut until the drum restarts (make necessary adjustments) and then continue operation.

NOTE: If the drum tends to ride up out of the cut, decrease travel speed, be sure the planer is level (front to back) and exert down pressure until the planer is riding on the wheel assemblies. For optimal cutting and reduced vibration, maintain down pressure on the planer with all four planer wheels on the ground when cutting.

NOTE: Avoid side to side movement while planing as this may cause excessive drum wear or planetary failure.

7. When you have reached the end of the pass, stop the skid-steer and raise the planer out of the cut. Reposition skid-steer for the next cut and repeat steps 4, 5 & 6. If you are not starting a new cut, raise the planer and retract the drum into the planer housing using the depth control cylinders. Do not transport the planer with drum turning.

OPERATING INSTRUCTIONS

CAUTION!



Periodic observation must be made of the transmission oil temperature indicator when planing with high flow hydraulic systems.

Depending on the ambient temperature and the duty cycle of the machine, hydraulic oil may overheat.

If indicator comes on, shut off the cold planer and allow the skid-steer to idle until the temperature falls below 160° Fahrenheit.

If the system continues running hot it may be necessary to clean any debris from the oil cooler and radiator. Check engine air filter and also the hydraulic oil level.

Continuous or excessive overheating may cause machine damage.

SPECIAL APPLICATIONS

LARGE AREA

BRADCO'S independent depth control design allows for continuous milling. Instead of planing pass 1, 3, 5 and then going back and resetting the planer for passes 2 and 4, the BRADCO planer allows for individual depth control from the operator's seat to enhance performance and continually mill large areas.

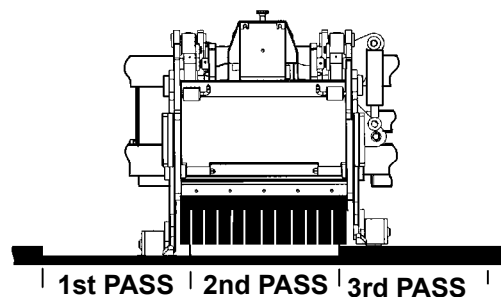
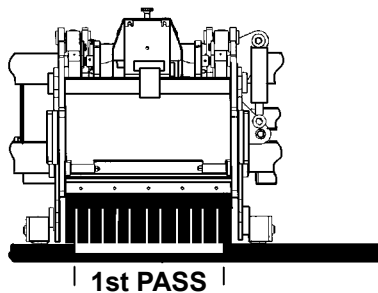

MILLING AROUND MANHOLES

For best visibility when milling around manholes it is recommended that the planer be shifted to the right. The planer is not designed to mill around tight corners, therefore it is recommended that four to six passes be made on each side of the manhole. NOTE: The more passes the less amount of manual clean-up required.

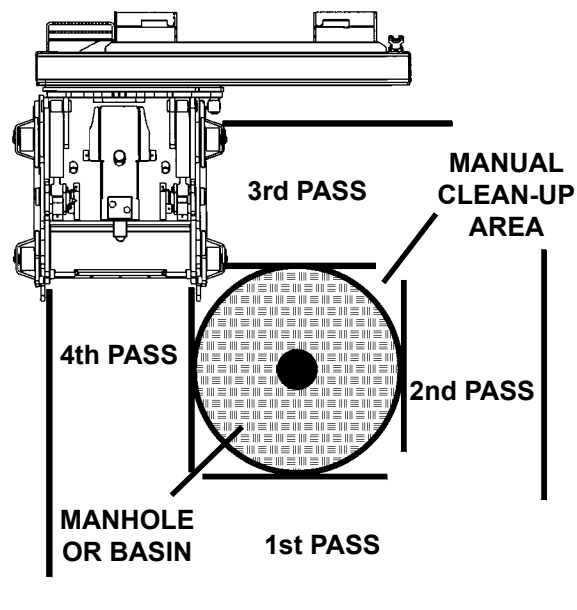

OPERATING INSTRUCTIONS

DEEP CUTS

To achieve a deep cut the width of the drum, make the first cut at the recommended depth for the material being milled and then reposition the planer at the beginning of the pass and reset for double the recommended depth. Example: Make the first cut with the depth controls set at 2" and then set the depth control at 4" for the second pass and so on and so forth until the desired depth is obtained.

To achieve a 6" cut of a large area it is recommended to cut the entire area at the recommended depth and then clear the spoil from the area before making the second cut. Removing the spoil between cuts will enhance the productivity of the planer and maintain an even cut.

If trying to achieve a critical cutting depth it is recommended that the spoil from one cut be cleared away before making another pass. This will eliminate the possibility of the planer riding on and off the spoil and creating an uneven surface.

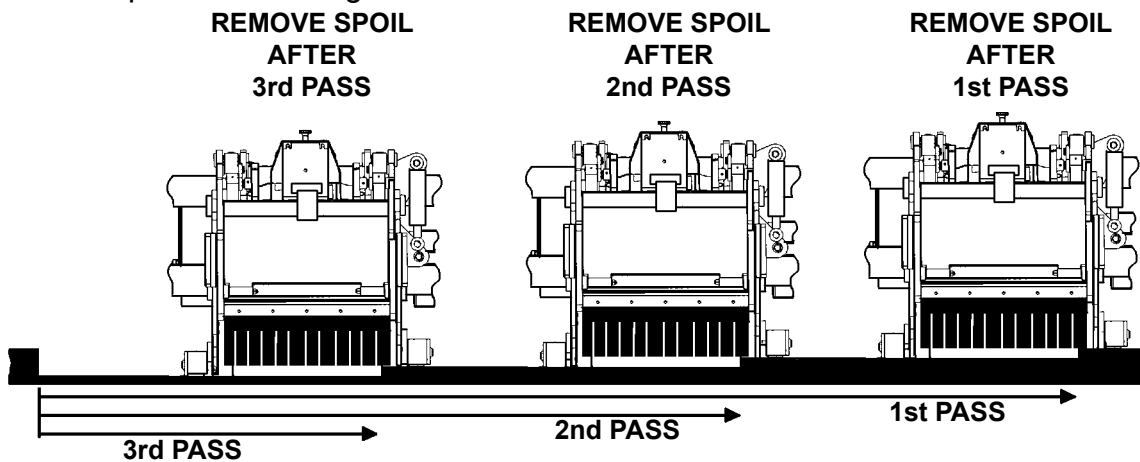

MILLING TAPER CUTS

When adding to or joining new paved surfaces to existing paving, a taper cut may be required at the interacting joints so the new paving would appear seamless. See the chart below for the angle of cut per size of cold planer.

Example: To achieve a taper cut from 0" to 4" over a 4' distance with a 24" wide cold planer it is recommended that you set one side of the planer at 2" and the other at 4" and the tilt set at 4° for the first pass. Then make a second pass with both sides of the planer set at 0" and the tilt still at 4°.

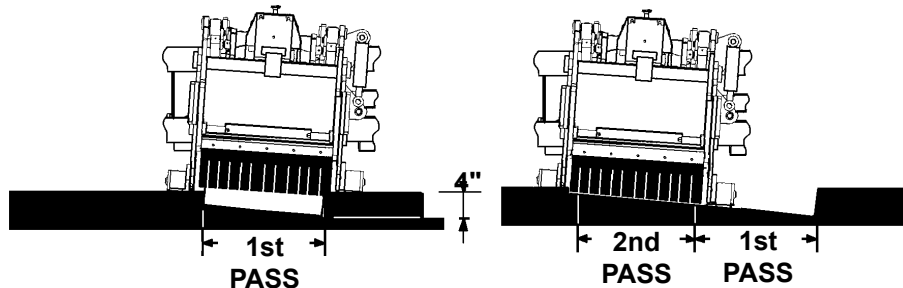

MODEL	ANGLE OF CUT PER OFFSET			
	1"	2"	3"	4"
16" COLD PLANER	3°	6°	8°	NA
18" COLD PLANER	3°	6°	8°	NA
24" COLD PLANER	2°	4°	6°	NA
30" COLD PLANER	2°	4°	5°	7°
40" COLD PLANER	1.5°	3°	4°	6°

9396 7-27-07-3

MAINTENANCE & SERVICE

LUBRICATION

GENERAL INFORMATION

Economical and efficient operation of any machine is dependent upon regular and proper lubrication of all moving parts with a quality lubricant. Neglect leads to reduced efficiency, wear, breakdown and needless replacement of parts.

All parts provided with grease fittings should be lubricated as indicated. If any grease fittings are missing, replace them immediately. Clean all fittings thoroughly before using the grease gun.

IMPORTANT: Avoid excessive greasing. Dirt collects on exposed grease and greatly increases wear. After greasing, wipe off excessive grease from fittings.

LUBRICATION SYMBOLS

The following symbols are used on the lubrication diagram below. It is reproduced here with its meaning for your convenience.



Lubricate daily or every 8 hours of operation, whichever comes last, with SAE Multi-Purpose Lubricant or equivalent SAE Multi-Purpose type grease.



Lubricate weekly or every 40 hours of operation, whichever comes last, with SAE Multi-Purpose Lubricant or equivalent SAE Multi-Purpose type grease.



CAUTION! SHUT OFF ENGINE BEFORE LUBRICATING EQUIPMENT.

The planer planetary is a sealed unit. If there is any sign of oil leaks please contact your nearest BRADCO dealer before carrying out any repairs, as there can be other causes for seal leaks. The planetary uses the Gear Oil (Castrol SP 320) for lubrication of gears and bearings. The unit holds approximately 2 quarts of gear oil.

The planetary gear oil should be drained and replaced after the first 8 months of use. Thereafter every 12 months or 2500 hours - whichever comes first.

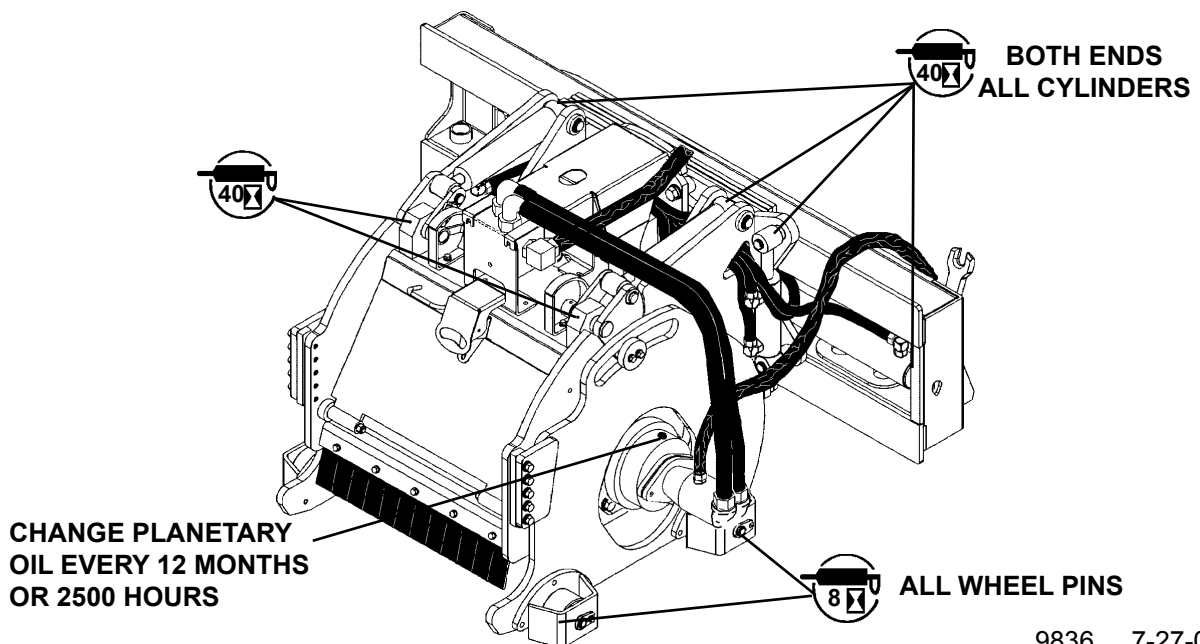

9836 7-27-07-2

MAINTENANCE & SERVICE

GENERAL INFORMATION

Regular maintenance is the key to long equipment life and safe operation. Maintenance requirements have been reduced to an absolute minimum. However it is very important that these maintenance functions be performed as described below.

WARNING! Never do any maintenance to the planer while it is running. Exercise the **MANDATORY SAFETY SHUTDOWN PROCEDURE BEFORE** working on or around the planer.



DAILY

- Check to be sure case drain coupler is completely engaged.
- Check skid-steer hydraulic system to ensure an adequate level of hydraulic oil.
- Check all hardware and tighten if necessary. See Section "O" for Bolt Torque Specifications.
- Check hydraulic system for hydraulic leaks.
- Check for missing or illegible Safety / Warning Decals.
- Check picks for freedom of rotation, flat spots and wear. Replace worn or missing picks or any picks that are not rotating freely or have flat spots.
- Visually inspect the machine for worn parts or cracked welds and repair as necessary.
- Lubricate grease fittings on Wheel pivot pins.

EVERY 40 HOURS

- Lubricate grease fittings on cylinder ends and front of planer.

EVERY 2500 HOURS OR 12 MONTHS

- Change gear oil in planetary.

WARNING! Escaping fluid under pressure can have sufficient force to penetrate the skin causing serious personal injury. Fluid escaping from a very small hole can be almost invisible. Use a piece of cardboard or wood, rather than hands to search for suspected leaks.



Keep unprotected body parts, such as face, eyes, and arms as far away as possible from a suspected leak. Flesh injected with hydraulic fluid may develop gangrene or other permanent disabilities.

If injured by injected fluid, see a doctor at once. If your doctor is not familiar with this type of injury, ask him to research it immediately to determine proper treatment.

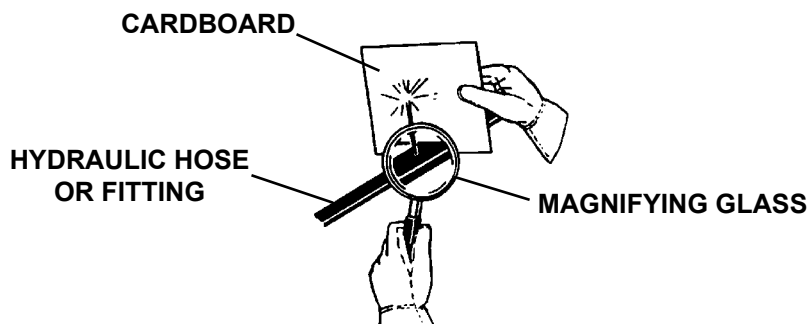

9398 7-27-07-3

MAINTENANCE & SERVICE

IMPORTANT: When replacing parts use only factory approved replacement parts. Manufacturer will not claim responsibility for use of unapproved parts or accessories and/or other damages as a result of their use.

PICK REPLACEMENT

Picks should be replaced if you are changing to a different application pick, they are broken, worn, flat spot or are seized in the pick holder and do not rotate freely.

WARNING! Always wear safety glasses with side shields when striking metal. Failure to heed could result in serious injury to the eyes or other parts of the body.



Do all pick maintenance through access door.

DO NOT attempt to check the picks with the planer in a raised position without first blocking the planer. Before exercising the **MANDATORY SAFETY SHUT-DOWN PROCEDURE** find an elevated surface to set the planer on or have a second person block the planer in place before shutting down the machine.

1. Open front access door.
2. Rotate the drum until the pick to be removed is conveniently accessible.
3. Hold the extracting tool (pick puller) in one hand and place the jaws in the groove of the pick, with the offset handle pointing away from the pick holder.
4. Using a lead hammer or rubber-headed mallet, hit the raised pad on the tool until the pick starts to move. Continue tapping until the pick is removed.
5. Insert the new pick into the jaws of the extracting tool (pick puller) so that the raised pad of the tool is pointing in the same direction as the pick point.
6. Position the new pick in the pick holder on the drum and with a lead hammer or rubber-headed mallet, hit the raised pad of the tool to start the pick into the pick holder. (Clean out any foreign material from the pick holder before installing the new pick.)
7. Once the pick is started into the pick holder strike the tool pad one strong blow to pop the pick into the holder.

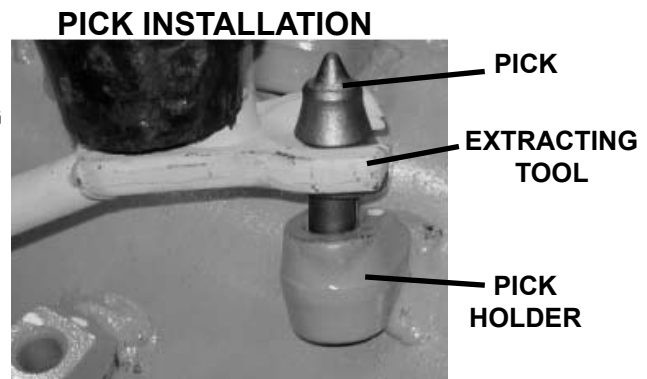
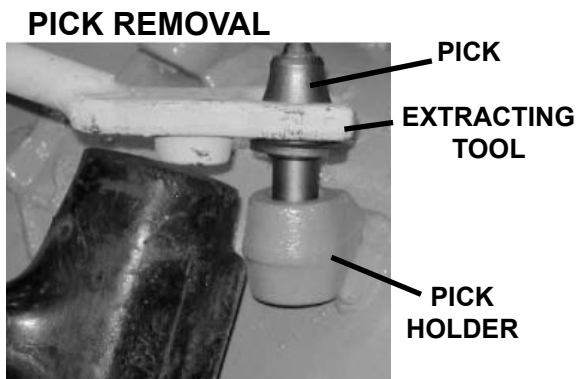

The pick is properly seated when its shoulder is against the face of the pick holder. Check to be sure the pick rotates freely.

MAINTENANCE & SERVICE

CHANGING THE DRUM

Due to the weight of the unit, place the planer in a convenient location with a hoist available for lifting the planer off the drum.

1. Remove the right side plate by first removing the two bolts in the retainer and then loosen the ten .50" bolts on the clamp plates. Slide the right side plate off.

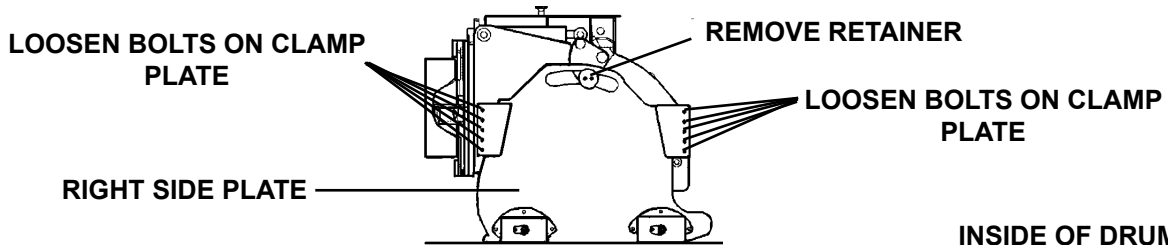

2. Remove the eight M16 hex nuts securing the drum to the planetary.
3. Using a pry bar, pry the drum off of the planetary and slide out until the drum clears the planetary. lift the planer off of the drum.
4. Install the new drum by positioning it over the studs on the planetary and installing the existing M16 hex nuts using Locktite 271 (Red) and torquing to 155 ft. lbs.
5. Reinstall the right side plate.

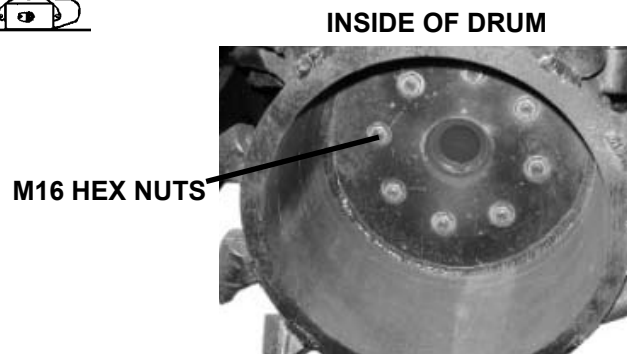

INSIDE OF DRUM

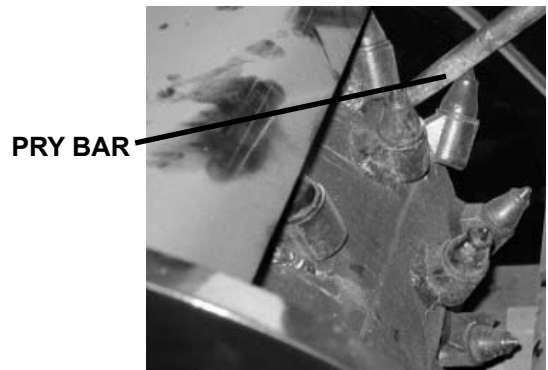

PRY DRUM OFF OF PLANETARY

CHANGING THE PLANETARY

To gain access to the planetary the drum must first be removed. Follow the above procedure for removing the drum.

1. Tag and disconnect the power and return hoses along with the case drain hose from the hydraulic motor and plug the motor ports to prevent contaminants from entering the hydraulic system.
2. Remove the .62" bolts securing the planetary to the planer and remove the planetary.

MAINTENANCE & SERVICE

3. Check to be sure the new planetary is filled with oil. If not, fill with approximately 2 quarts of Castrol SP 320 gear oil.
4. Remove the hydraulic motor from the planetary. Scrape any silicone from the hydraulic motor and apply new RV 10 silicone to the motor to seal the connection between the motor and the planetary. Bolt the hydraulic motor onto the new planetary using the existing hardware.
5. Position the new planetary into the planer housing and reinstall the .62" capscrews, flat washers and lock nuts. Check to ensure that the hydraulic motor is in the correct position with the ports turned up. Torque to specification
6. Reinstall the drum as described in "CHANGING THE DRUM".
7. Re-connect the hydraulic hoses and fittings to the motor.

CHANGING HYDRAULIC MOTOR

1. Position the planer on its side or in such a fashion that the planetary oil will not leak out when replacing the motor.
2. Tag and disconnect the power and return hoses along with the case drain hose from the hydraulic motor.
3. Remove the capscrews securing the motor to the planetary.
4. Scrape the mating surface of the planetary, removing all existing silicone, to prepare it for the new motor.
5. Apply new RV 10 silicone to the motor to seal the connection between the motor and the planetary. Bolt the new hydraulic motor onto the planetary using the existing hardware. (Check to ensure that the hydraulic motor is in the correct position with the ports turned up.) Torque to specification
6. Re-connect the hydraulic hoses and fittings to the motor.

**TAG AND REMOVE
HYDRAULIC HOSES
FROM MOTOR**

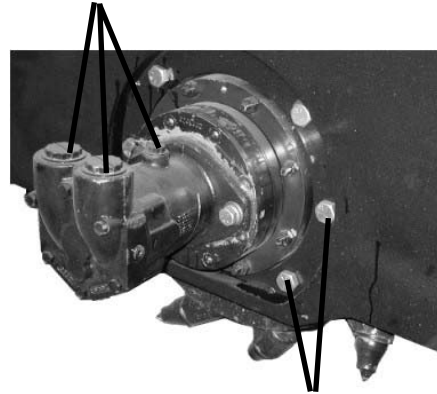

**REMOVE PLANETARY FROM PLANER BY
UNBOLTING .62" X 2.50" CAPSCREWS**

MAINTENANCE AND SERVICE

CYLINDER SEAL REPLACEMENT

The following information is provided to assist you in the event you should need to repair or rebuild a hydraulic cylinder. When working on hydraulic cylinders, make sure that the work area and tools are clean and free of dirt to prevent contamination of the hydraulic system and damage to the hydraulic cylinders. Always protect the active part of the cylinder rod (the chrome section). Nicks or scratches on the surface of the rod could result in cylinder failure. Clean all parts thoroughly with a cleaning solvent before reassembly.

DISASSEMBLY PROCEDURE

IMPORTANT: Do not contact the active surface of the cylinder rod with the vise. Damage to the rod could result.

THREADED TYPE GLAND

1. Rotate the gland with a spanner wrench counterclockwise until the gland is free of the cylinder tube.
2. Pull the cylinder rod from the cylinder tube and inspect the piston and the bore of the cylinder tube for deep scratches or galling. If damaged, the piston AND the cylinder tube must be replaced.

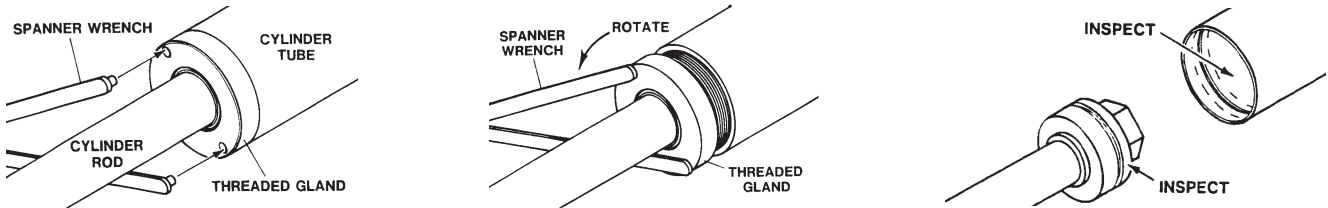

3. Remove the hex nut, piston, flat washer or spacer tube (if so equipped), and gland from the cylinder rod. If the cylinder rod is rusty, scratched, or bent, it must be replaced.
4. Remove and discard all the old seals.



ASSEMBLY PROCEDURE

IMPORTANT: Replace all seals even if they do not appear to be damaged. Failure to replace all seals may result in premature cylinder failure. **NOTE:** Seal kits will service most cylinders of similar bore size and rod diameter.

1. Install the cylinder rod seal in the gland first. Be careful not to damage the seal in the process, as it is somewhat difficult to install.

NOTE: A special installation tool (Part #65349) is available to help with installing the seal. Simply fit the end of the tool over the seal so that the large prong of the tool is on the outside of the seal, and the two smaller prongs on the inside. The lip of the seal should be facing towards the tool. Rotate the handles on the tool around to wrap the seal around the end of the tool.

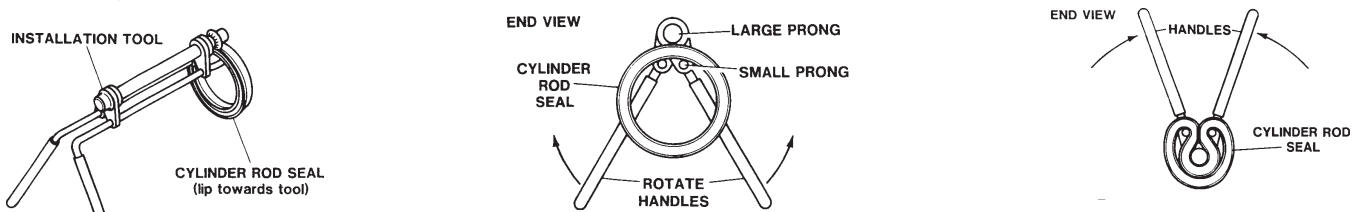

10356 10-13-05

MAINTENANCE AND SERVICE

Now insert the seal into the gland from the inner end. Position the seal in its groove, and release and remove the tool. Press the seal into its seat the rest of the way by hand.

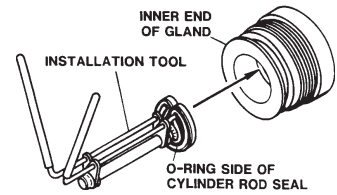

2. Install the new piston ring, rod wiper, O-rings and backup washers, if applicable, on the piston.

Be careful not to damage the seals. Caution must be used when installing the piston ring. The ring must be stretched carefully over the piston with a smooth, round, pointed tool.

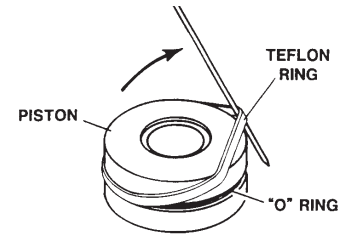

3. After installing the rod seal inside the gland, as shown in step #1, install the external seal.

NOTE: Threaded glands may have been equipped with a separate O-ring and backup washer system or a polypak (all in one) type seal. Current seal kits contain a polypak (all in one) type seal to replace the discarded seal types on ALL THREADED GLANDS.

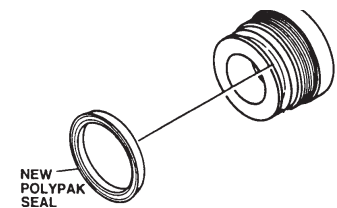

4. Slide the gland onto the cylinder rod, being careful not to damage the rod wiper. Then install the spacer, or flat washer (if so equipped), small o-ring, piston, and hex nut onto the end of the cylinder rod.
5. Secure the cylinder rod (mounting end) in a vise with a support at its center. Torque the nut to the amount shown for the thread diameter of the cylinder rod (see chart).

Thread Diameter	POUNDS - FEET
7/8"	150-200
*1"	230-325
1-1/8"	350-480
1-1/4"	490-670
1-3/8"	670-900
* 1" Thread Diameter WITH 1.25" Rod Diameter Min. 230 ft. lbs. Max. 250 ft. lbs.	

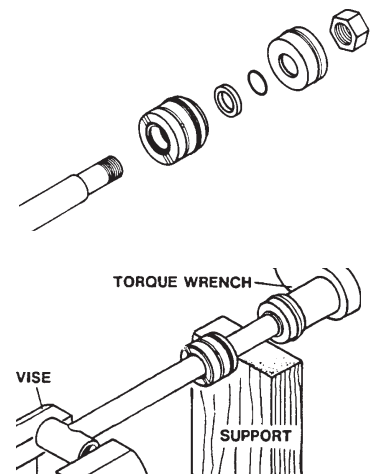

IMPORTANT: Do not contact the active surface of the cylinder rod with the vise. Damage to the rod could result.

6. Apply a lubricant (such as Lubriplate #105) to the piston and teflon ring. Insert the cylinder rod assembly into the cylinder tube.

IMPORTANT: Ensure that the piston ring fits squarely into the cylinder tube and piston groove, otherwise the ring may be damaged and a leak will occur.

7. Use a spanner wrench to rotate the gland clockwise into the cylinder. Continue to rotate the gland with the spanner wrench until it is tight.

WARNING! Cylinders serviced in the field are to be tested for leakage prior to the attachment being placed in work. Failure to test rebuilt cylinders could result in damage to the cylinder and/or the attachment, cause severe personal injury or even death.



TROUBLESHOOTING

<u>PROBLEM</u>	<u>POSSIBLE CAUSE</u>	<u>POSSIBLE REMEDY</u>
Motor on the planer will not operate.	Auxiliary hoses not hooked up to the skid-steer.	Engage Couplers
	Obstruction in hydraulic lines.	Remove obstruction and replace if necessary.
	Hydraulic motor damaged or seals blown.	Call Bradco service department for instructions.
	Skid-steer auxiliary valve not engaged.	Engage auxiliary valve.
Drum rotates sluggishly.	Insufficient hydraulic flow from the skid-steer.	Refer to skid-steer's owners manual.
	Damaged quick coupler.	Replace if necessary.
	Hydraulic motor damaged or seals blown.	Call Bradco service department for instructions.
	Oil filter on skid-steer is dirty.	Refer to skid-steer's owners manual.
Leaking Oil.	Loose or damaged hydraulic line.	Tighten or replace.
	O-Rings on fittings damaged.	Replace if necessary.
	Hydraulic motor damaged or seals blown.	Call Bradco service department for instructions.
	Fittings loose or damaged.	Tighten or replace.
	Cylinder seals damaged.	Replace cylinder seals.
Insufficient power.	Insufficient hydraulic flow from the skid-steer.	Refer to skid-steer's owners manual.
	Relief valve setting adjusted too low.	Refer to skid-steer's owners manual.
	Hydraulic motor damaged or seals blown.	Call Bradco service department for instructions.
	Oil filter on skid-steer is dirty.	Refer to skid-steer's owners manual.
Drum rotates in the wrong direction.	Hoses from the valve to the motor incorrectly connected.	Switch hoses at the motor end.
Excessive vibration during planing operation.	Picks are worn or broken.	Visually inspect the picks and replace as necessary.
	Picks contain flat spots or are not rotating freely.	Visually inspect the picks and replace as necessary.
	Insufficient down force due to incorrect operating procedure.	Refer to the Operating section of this manual.

TROUBLESHOOTING

<u>PROBLEM</u>	<u>POSSIBLE CAUSE</u>	<u>POSSIBLE REMEDY</u>
Excessive oil temperature.	Hydraulic oil level too low.	Refer to skid-steer's owners manual
	Obstruction in hydraulic lines.	Remove obstruction and replace if necessary.
	Hydraulic oil or oil filter in skid-steer is dirty.	Refer to skid-steer's owners manual.
	Relief valve setting adjusted too low.	Refer to skid-steer's owners manual.
	Couplers not engaged.	Engage couplers.
A Hydraulic cylinder not operating.	Insufficient hydraulic flow from the skid-steer.	Refer to skid-steer's owners manual.
	Cylinder rod bent.	Visually inspect the cylinder for damage.
	Cylinder seals damaged.	Replace cylinder seals.
	Obstruction in hydraulic lines.	Remove obstruction and replace if necessary.
All hydraulic cylinders not functioning.	Blown fuse on skid-steer.	Refer to skid-steer's owners manual.
	Damaged electrical wiring.	Test and replace if necessary.
	Solenoid valve spool bent.	Replace spool.
	Nut on Solenoid valve too tight	Loosen nut.
Hydraulic cylinders only operating in one direction.	Contaminants in the hydraulic system and solenoid valve.	Remove spool from solenoid valve and check for foreign material. Clean or replace. Remove spool from solenoid valve and check seals for damage. Replace if necessary.
	Damaged electrical wiring.	Test and replace if necessary.
	Solenoid valve spool bent.	Replace spool.
	Nut on Solenoid valve too tight	Loosen nut.

BOLT TORQUE

BOLT TORQUE SPECIFICATIONS

GENERAL TORQUE SPECIFICATION TABLE

Use the following torques when special torques are not given. These values apply to fasteners as received from suppliers, dry, or when lubricated with normal engine oil. They do not apply if special graphited or moly disulphide greases or other extreme pressure lubricants are used. This applies to both UNF and UNC threads. Remember to always use grade five or better when replacing bolts.

IMPORTANT: On all PLATED GRADE 8 bolts, reduce torque 15% from listed bolt torque specification.

SAE Grade No.		2				5				8*			
Bolt head identification marks as per grade. NOTE: Manufacturing Marks Will Vary													
		TORQUE		TORQUE		TORQUE		TORQUE		TORQUE		TORQUE	
Bolt Size		Pounds Feet		Newton-Meters		Pounds Feet		Newton-Meters		Pounds Feet		Newton-Meters	
Inches	Millimeters	Min.	Max.	Min.	Max.	Min.	Max.	Min.	Max.	Min.	Max.	Min.	Max.
1/4	6.35	5	6	7	8	9	11	12	15	12	15	16	20
5/16	7.94	10	12	14	16	17	20.5	23	28	24	29	33	39
3/8	9.53	20	23	27	31	35	42	48	57	45	54	61	73
7/16	11.11	30	35	41	47	54	64	73	87	70	84	95	114
1/2	12.70	45	52	61	70	80	96	109	130	110	132	149	179
9/16	14.29	65	75	88	102	110	132	149	179	160	192	217	260
5/8	15.88	95	105	129	142	150	180	203	244	220	264	298	358
3/4	19.05	150	185	203	251	270	324	366	439	380	456	515	618
7/8	22.23	160	200	217	271	400	480	542	651	600	720	814	976
1	25.40	250	300	339	406	580	696	787	944	900	1080	1220	1464
1-1/8	25.58	-	-	-	-	800	880	1085	1193	1280	1440	1736	1953
1-1/4	31.75	-	-	-	-	1120	1240	1519	1681	1820	2000	2468	2712
1-3/8	34.93	-	-	-	-	1460	1680	1980	2278	2380	2720	3227	3688
1-1/2	38.10	-	-	-	-	1940	2200	2631	2983	3160	3560	4285	4827

* Thick Nuts must be used with Grade 8 bolts

METRIC BOLT TORQUE SPECIFICATIONS

Size of Screw	Grade No.	Coarse Thread			Fine Thread		
		Pitch (mm)	Pounds Feet	Newton-Meters	Pitch (mm)	Pounds Feet	Newton-Meters
M6	5.6	1.0	3.6-5.8	4.9-7.9	-	-	-
	8.8		5.8-4	7.9-12.7		-	-
	10.9		7.2-10	9.8-13.6		-	-
M8	5.6	1.25	7.2-14	9.8-19	1.0	12-17	16.3-23
	8.8		17-22	23-29.8		19-27	25.7-36.6
	10.9		20-26	27.1-35.2		22-31	29.8-42
M10	5.6	1.5	20-25	27.1-33.9	1.25	20-29	27.1-39.3
	8.8		34-40	46.1-54.2		35-47	47.4-63.7
	10.9		38-46	51.5-62.3		40-52	54.2-70.5
M12	5.6	1.75	28-34	37.9-46.1	1.25	31-41	42-55.6
	8.8		51-59	69.1-79.9		56-68	75.9-92.1
	10.9		57-66	77.2-89.4		62-75	84-101.6
M14	5.6	2.0	49-56	66.4-75.9	1.5	52-64	70.5-86.7
	8.8		81-93	109.8-126		90-106	122-143.6
	10.9		96-109	130.1-147.7		107-124	145-168
M16	5.6	2.0	67-77	90.8-104.3	1.5	69-83	93.5-112.5
	8.8		116-130	157.2-176.2		120-138	162.6-187
	10.9		129-145	174.8-196.5		140-158	189.7-214.1
M18	5.6	2.0	88-100	119.2-136	1.5	100-117	136-158.5
	8.8		150-168	203.3-227.6		177-199	239.8-269.6
	10.9		175-194	237.1-262.9		202-231	273.7-313
M20	5.6	2.5	108-130	146.3-176.2	1.5	132-150	178.9-203.3
	8.8		186-205	252-277.8		206-242	279.1-327.9
	10.9		213-249	288.6-337.4		246-289	333.3-391.6

10360 6-8-95-2

SPECIFICATIONS

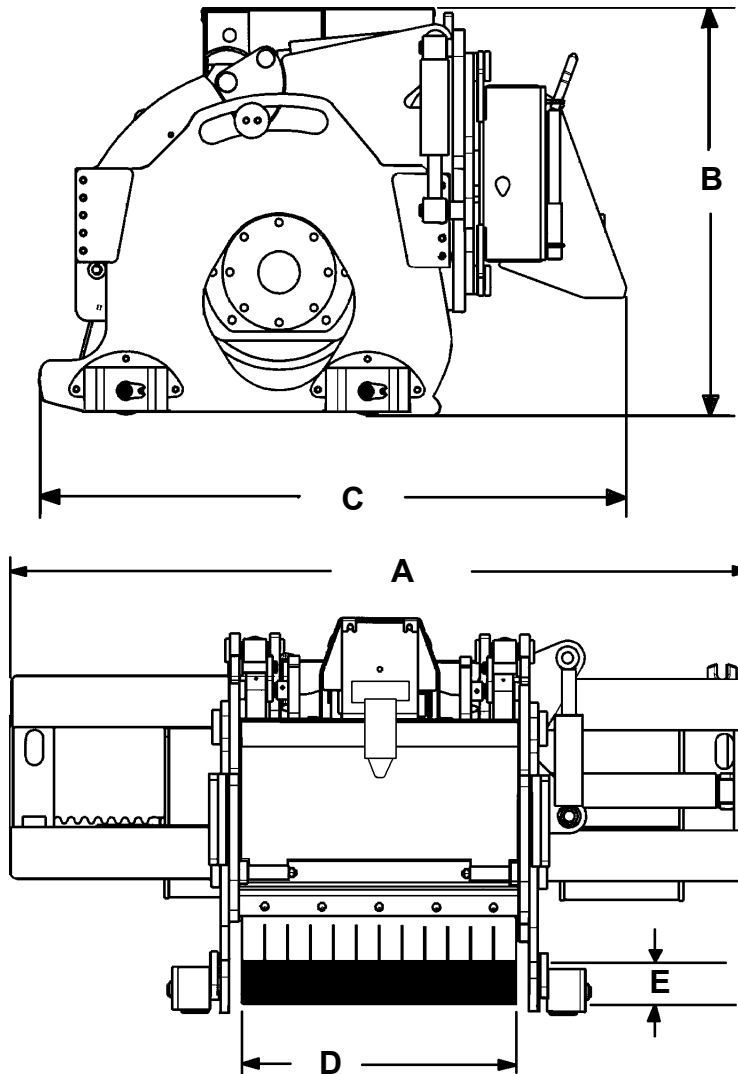

DESCRIPTION	SPECIFICATION				
	16"	18"	24"	30"	40"
A. Overall Width	64.94"	64.94"	64.94"	64.94"	64.94"
B. Overall Height	34.57"	34.57"	34.57"	34.57"	34.57"
C. Overall Length	50.30"	50.30"	50.30"	50.30"	50.30"
D. Planing Width.....	16.00"	18.00"	24.00"	30.00"	40.00"
E. Planing Depth	0"-5.00"	0"-5.00"	0"-5.00"	0"-5.00"	0"-5.00"
Drum Diameter		22.00"	22.00"	22.00"	22.00"
Number of Picks (Full size drum)	43	45	57	69	89
Weight (lbs)	2150#	2200#	2400#	2600#	3100"
High Flow Requirement	22-40 GPM				
Operating Pressure	2500-3500 PSI				

LIMITED WARRANTY

All new Bradco products are warranted to be free from defects in materials or workmanship which may cause failure under normal usage and service when used for the purpose intended.

In the event of failure within twenty four (24) months from initial retail sale, lease or rental date (excluding cable, ground engaging parts such as sprockets, digging chain, bearings, teeth, tamping and demolition heads, blade cutting edges, pilot bits, auger teeth, auger heads & broom bristles), if after examination, Bradco determines failure was due to defective material and/or workmanship, parts will be repaired or replaced. Bradco may request defective part or parts be returned prepaid to them for inspection at their place of business at Delhi, Iowa, or to a location specified by Bradco.

Any claims under this warranty must be made within fifteen (15) days after the Buyer learns of the facts upon which such claim is based. All claims not made in writing and received by Bradco within the time period specified above shall be deemed waived.

THIS WARRANTY IS IN LIEU OF ALL OTHER WARRANTIES EXPRESSED OR IMPLIED AND THERE ARE NO WARRANTIES OF MERCHANTABILITY OR OF FITNESS FOR A PARTICULAR PURPOSE. IN NO EVENT SHALL BRADCO BE LIABLE FOR CONSEQUENTIAL OR SPECIAL DAMAGE.

BRADCO'S LIABILITY FOR ANY AND ALL LOSSES AND DAMAGES TO BUYER, RESULTING FROM ANY CAUSE WHATSOEVER, INCLUDING BRADCO'S NEGLIGENCE, IRRESPECTIVE OF WHETHER SUCH DEFECTS ARE DISCOVERABLE OR LATENT, SHALL IN NO EVENT EXCEED THE PURCHASE PRICE OF THE PARTICULAR PRODUCTS WITH RESPECT TO WHICH LOSSES OR DAMAGES ARE CLAIMED, OR, AT THE ELECTION OF BRADCO, THE REPAIR OR REPLACEMENT OF DEFECTIVE OR DAMAGED PRODUCTS.

PLANER ASSEMBLY

16", 18", 24", 30" & 40" COLD PLANER ASSEMBLIES

DIAGRAM 1 OF 3

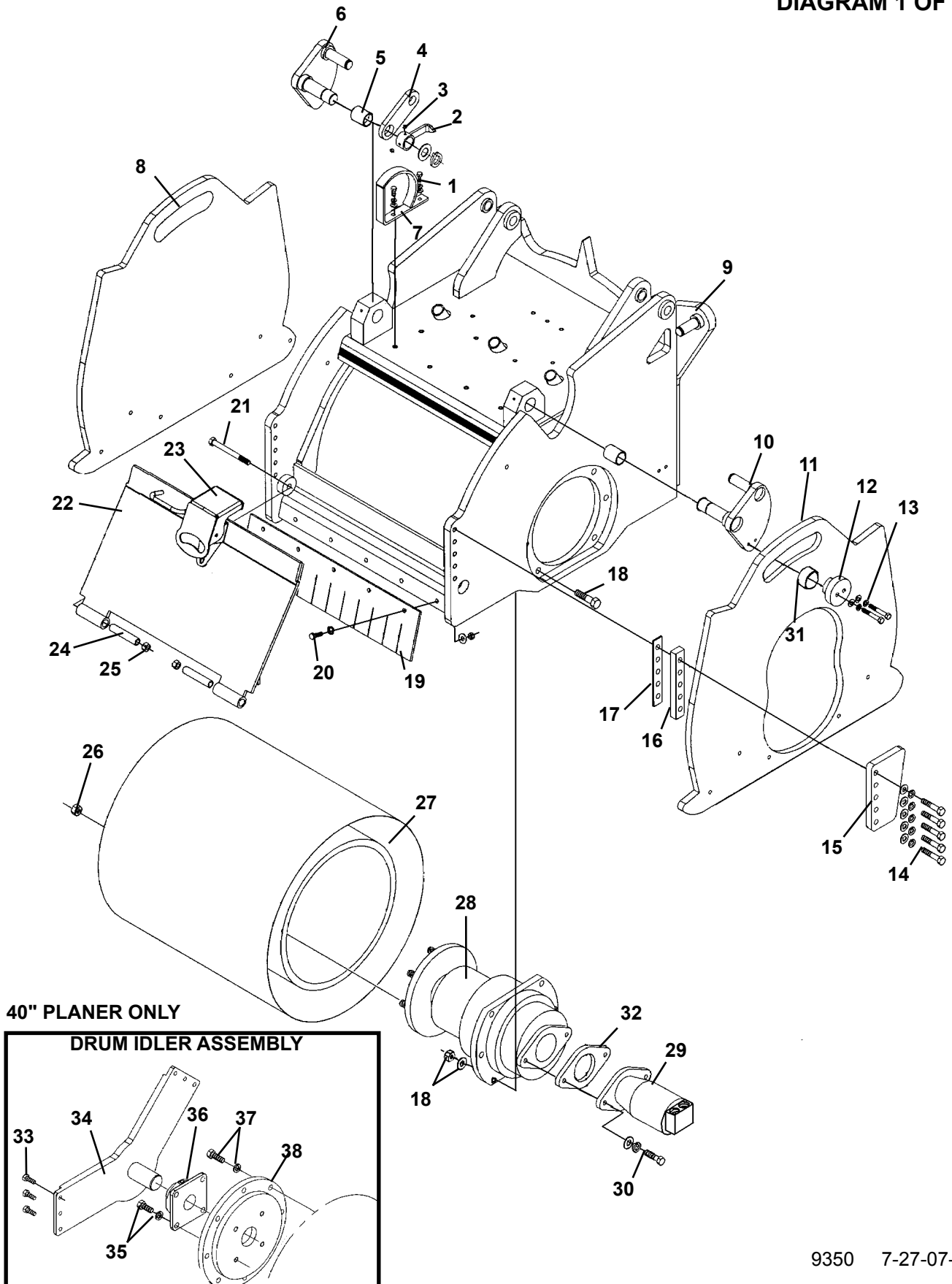

PLANER ASSEMBLY

16", 18", 24", 30" & 40" COLD PLANER ASSEMBLIES

LIST 1 OF 3

<u>ITEM</u>	<u>REQ'D</u>	<u>PART NO.</u>	<u>DESCRIPTION</u>
1	4	1022	.31" UNC X 1.00" Hex Capscrew
	4	1502	.31" Lock Washer
	4	1513	.31" Flat Washer
2	2	17737	Depth Indicator
3	4	1589	Set Screw
4	2	17729	Pivot Plate
5	2	18685	Bushing
6	1	17677	Right Link
	1	1652	1.25" Snap Ring
	1	64727	1.25" Thrust Washer
7	2	17734	Bracket
8	1	17725	Right Side Plate
9	1	18651	Cannister (16" & 18" Planer)
	1	17600	Cannister (24" Planer)
	1	19431	Cannister (30" Planer)
	1	101085	Cannister (40" Planer)
	2	6616	Grease Fitting
10	1	17676	Left Link
	1	1652	1.25" Snap Ring
	1	64727	1.25" Thrust Washer
11	1	17722	Left Side Plate
12	2	17728	Retainer
13	4	1092	.50" UNC X 2.00" Hex Capscrew
	4	1505	.50" Lock Washer
	20	1965	.50" UNC X 2.50" Hex Capscrew Grade 8
14	20	1505	.50" Lock Washer
	20	1646	.50" Hard Flat Washer
	4	17727	Clamp Plate
15	4	17727	Clamp Plate
16	4	17731	Spacer
17	8	18681	Shim
18	6	1821	.62" UNC X 2.50" Hex Capscrew - Grade 8
	6	1627	.62" Hard Flat Washer
	6	1839	.62" UNC Deformed Lock Nut
19	1	19886	Rubber Deflector (16" & 18" Planer)
	1	19887	Rubber Deflector (24" Planer)
	1	19888	Rubber Deflector (30" Planer)
	1	101125	Rubber Deflector (40" Planer)

NOTE: There may be a slight quantity difference in hardware between the various cold planers. Quantity listed is for the 24" planer.

9351 7-27-07-5

PLANER ASSEMBLY

16", 18", 24", 30" & 40" COLD PLANER ASSEMBLIES

DIAGRAM 2 OF 3

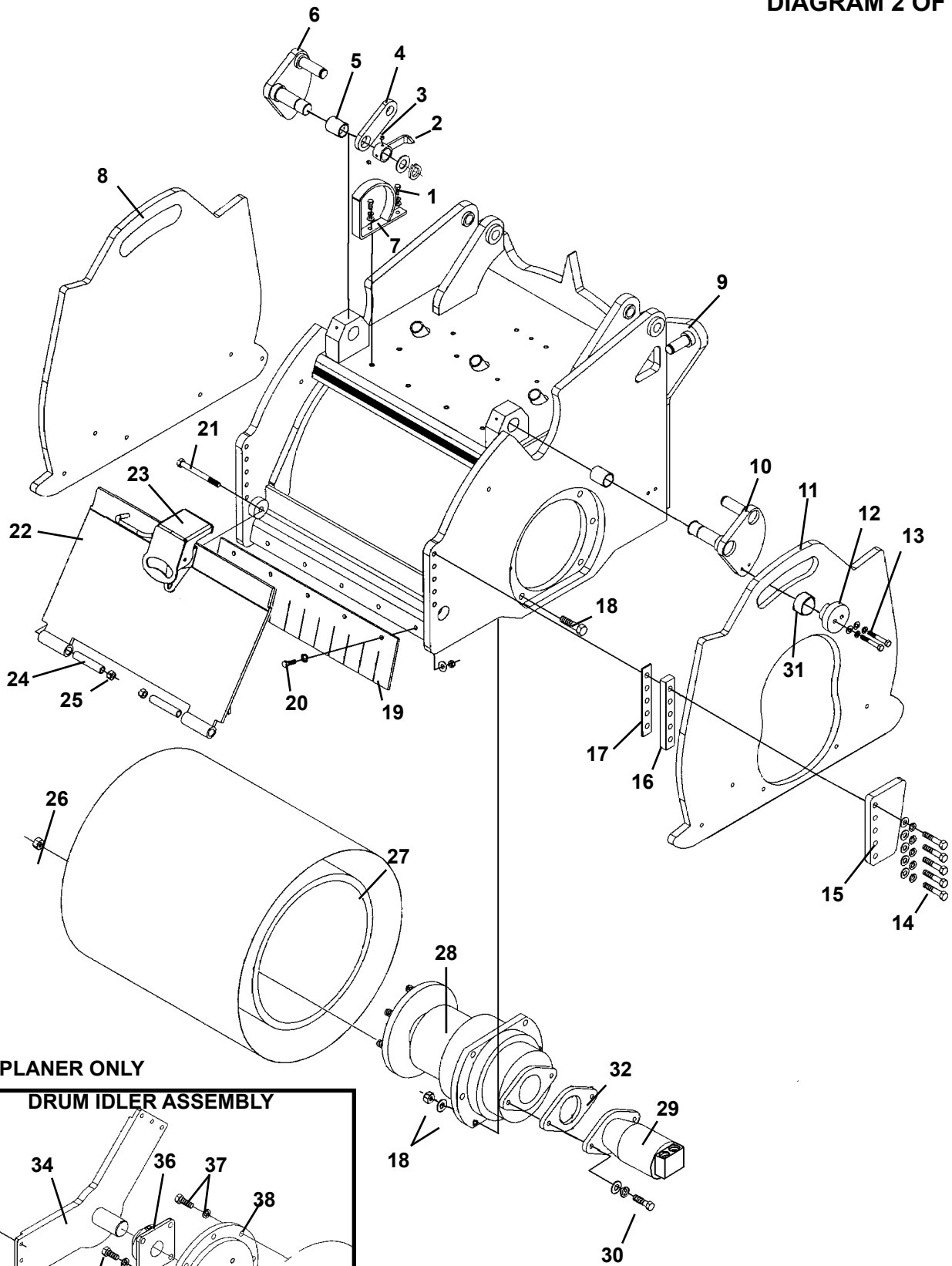

40" PLANER ONLY

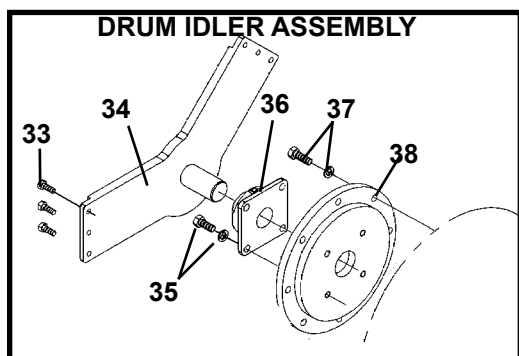

9354 7-27-07-6

PLANER ASSEMBLY

16", 18", 24", 30" & 40" COLD PLANER ASSEMBLIES

LIST 2 OF 3

<u>ITEM</u>	<u>REQ'D</u>	<u>PART NO.</u>	<u>DESCRIPTION</u>
20	5	1044	.38" UNC X 1.25" Hex Capscrew
	5	1503	.38" Lock Washer
	5	1514	.38" Flat Washer
	5	1226	.38" UNC Hex Nut
	21	2	1102
22	1	18656	Door (16" & 18" Planer)
	1	17663	Door (24" Planer)
	1	19545	Door (30" Planer)
	1	101130	Door (40" Planer)
23	1	19560	Latch
	2	1043	.38" UNC X 1.00" Hex Capscrew
	2	1503	.38" Lock Washer
	2	1514	.38" Flat Washer
	2	1226	.38" UNC Hex Nut
24	2	17666	Spacer Tube
25	2	1841	.50" UNC Deformed Lock Nut
26	8	10003	.62" UNF Deformed Oval Lock Nut
27	1	18534	Drum Assembly with Teeth (16" Planer)
	1	18535	Drum Assembly with Teeth (18" Planer)
	1	18524	Drum Assembly with Teeth (24" Planer)
	1	19712	Drum Assembly with Teeth (30" Planer)
	1	101080	Drum Assembly with Teeth (40" Planer)
28	1	18970	Planetary
	--	30355	Replacement Oil Fill Plug
29	--	17776	Hydraulic Motor (Not available on 40" Planer) 2.0 Cu. In. / Blue / 22 GPM - 28 GPM
	--	17777	Hydraulic Motor Option (Not available on 40" Planer) 2.5 Cu. In. / Black / 29 GPM - 35 GPM
	--	17778	Hydraulic Motor Option (Standard on 40" Planer) 3.0 Cu. In. / Red / 36 GPM - 44 GPM
	**	45845	Replacement Seal Kit
30	2	1090	.50" UNC X 1.50" Hex Capscrew
	2	1646	.50" Hard Flat Washer
	2	1505	.50" Lock Washer
31	2	101467	Spacer Tube
32	1	102594	Motor Gasket
33	6	1780	.50" UNC X 1.25" Hex Capscrew
34	1	101140	Idler Plate
35	4	1832	.62" UNC X 1.50" Hex Capscrew - Grade 8
	4	1506	.62" Lock Washer
36	1	100947	Bearing
37	8	10070	.62" UNC X 1.75" Hex Capscrew - Grade 8
	8	1506	.62" Lock Washer
38	1	103025	Bearing Mounting Plate

**** Field replacement of internal motor seals voids warranty.**

NOTE: There may be a slight quantity difference in hardware between the various cold planers. Quantity listed is for the 24" planer.

9854 7-27-07-3

PLANER ASSEMBLY

16", 18", 24", 30" & 40" COLD PLANER ASSEMBLIES

DIAGRAM 3 OF 3

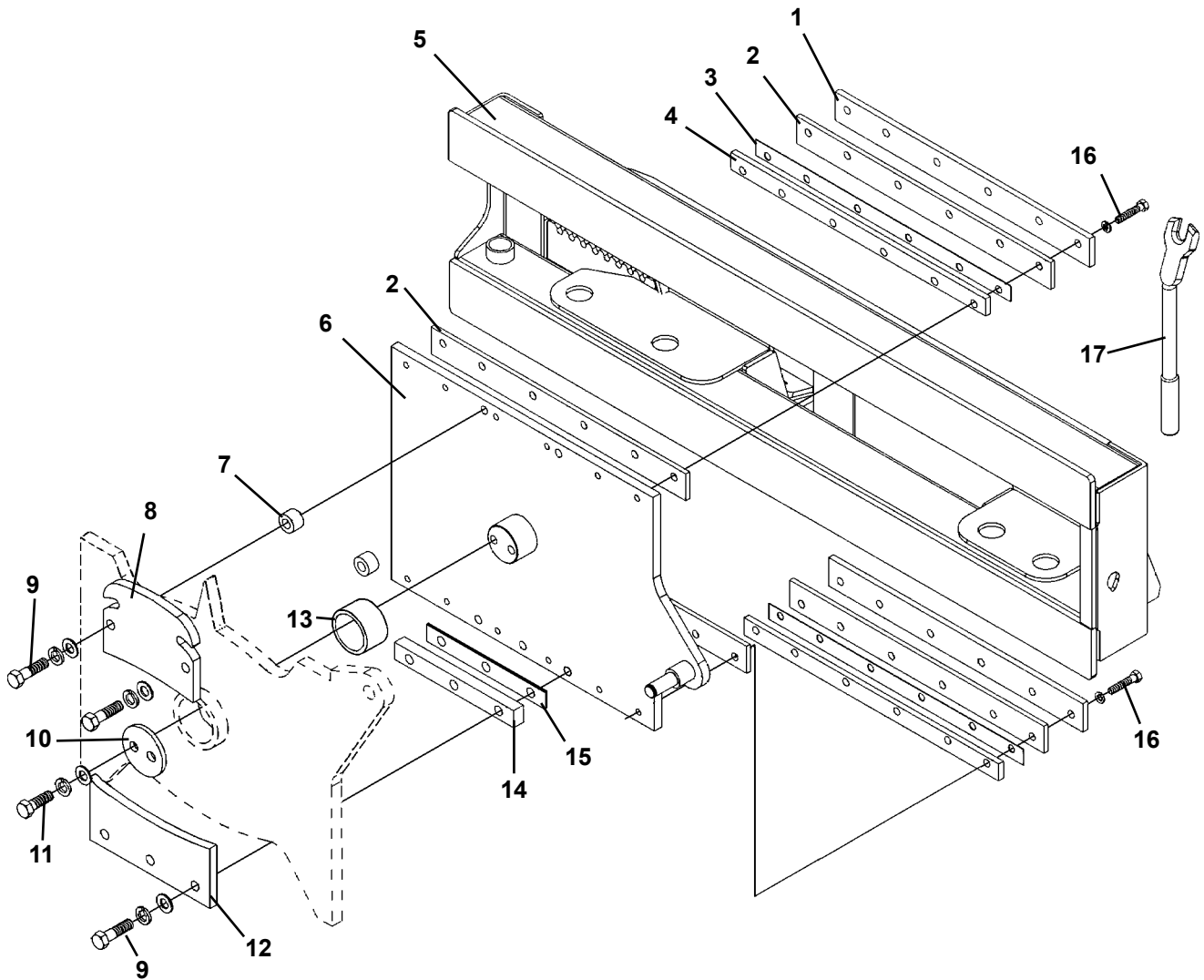

9352 7-30-07-4

PLANER ASSEMBLY

16", 18", 24", 30" & 40" COLD PLANER ASSEMBLIES

LIST 3 OF 3

<u>ITEM</u>	<u>REQ'D</u>	<u>PART NO.</u>	<u>DESCRIPTION</u>
1	2	19196	Clamp Plate (16" & 18" Planer)
	2	17757	Clamp Plate (24" Planer)
	2	19548	Clamp Plate (30" Planer)
	2	101118	Clamp Plate (40" Planer)
2	4	19198	Wear Strip (16" & 18" Planer)
	4	89611	Wear Strip (24" Planer)
	4	19550	Wear Strip (30" Planer)
	8	19198	Wear Strip (40" Planer)
3	2	19199	Shim (16" & 18" Planer)
	2	89612	Shim (24" Planer)
	2	19551	Shim (30" Planer)
	2	101121	Shim (40" Planer)
4	2	19197	Spacer Plate (16" & 18" Planer)
	2	17758	Spacer Plate (24" Planer)
	2	19549	Spacer Plate (30" Planer)
	2	101119	Spacer Plate (40" Planer)
5	1	89501	Side Shift Frame
6	1	18648	Pivot Plate (16" & 18" Planer)
	1	17661	Pivot Plate (24" Planer)
	1	19543	Pivot Plate (30" Planer)
	1	101116	Pivot Plate (40" Planer)
7	2	17732	Spacer Tube
8	1	17730	Plate
9	5	1142	.75" UNC X 2.75" Hex Capscrew
	5	1507	.75" Lock Washer
	5	1649	.75" Hard Flat Washer
10	1	88996	Cap Plate
11	2	1139	.75" UNC X 2.00" Hex Capscrew
	2	1507	.75" Lock Washer
	2	1649	.75" Hard Flat Washer
12	1	88995	Guide Plate
13	1	89436	Bushing
14	1	17733	Spacer
15	1	18893	Shim
16	12	1818	.50" UNC X 2.75" Hex Capscrew Grade 8
	12	1505	.50" Lock Washer
17	1	100213	Extracting Tool (Pick Puller)

NOTE: There may be a slight quantity difference in hardware between the various cold planers. Quantity listed is for the 24" planer.

9353 7-30-07-4

DRUM AND PICK OPTIONS

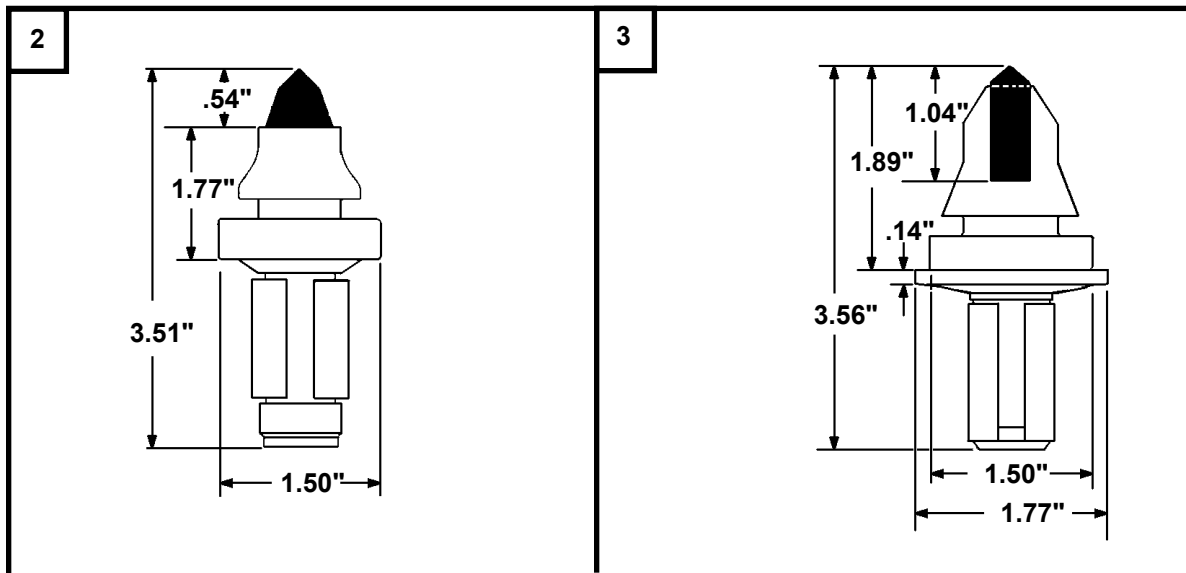
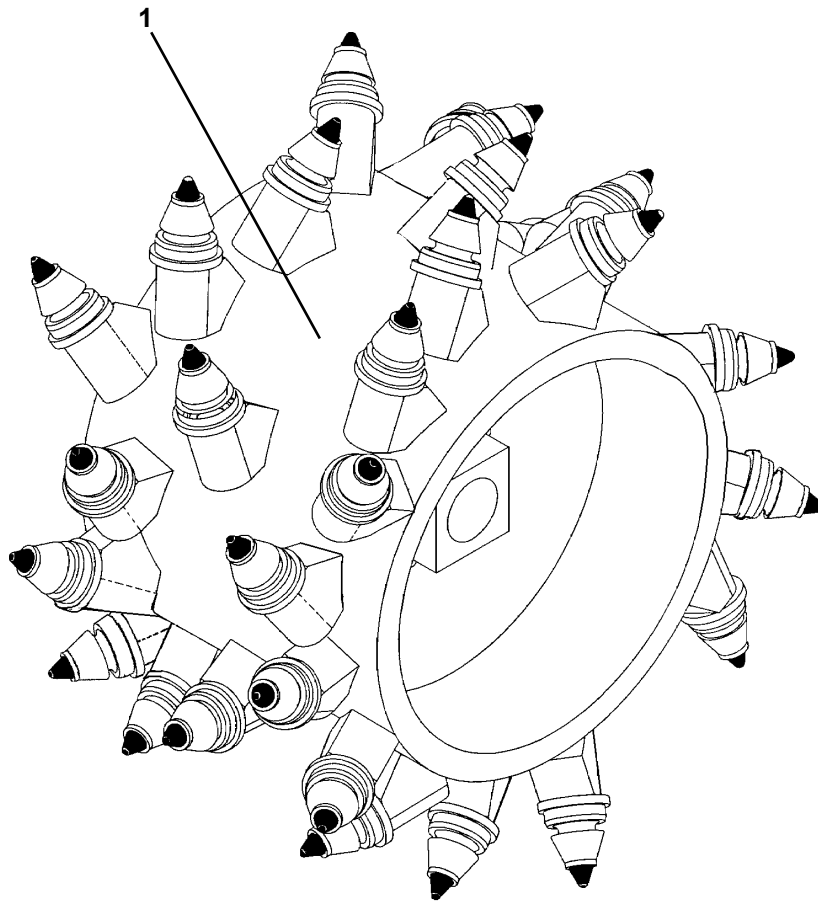

DRUM AND PICK OPTIONS

DRUM OPTIONS (INCLUDES STANDARD ALL-PURPOSE PICKS)

#1 DESCRIPTION	<u>PART NUMBER</u>	<u>PICK QTY</u>
16" Standard Drum (16" Cold Planer)	18534	43
18" Standard Drum (18" Cold Planer)	18535	45
24" Standard Drum (24" Cold Planer)	18524	57
30" Standard Drum (30" Cold Planer)	19712	69
40" Standard Drum (40" Cold Planer)	101080	89
2.50" Slot Cutter Drum (All Planers)	100642	18
4.00" Slot Cutter Drum (All Planers)	100643	18
6.00" Slot Cutter Drum (All Planers)	100644	20

#2 DESCRIPTION	<u>PART NUMBER</u>
General Purpose Application Pick	18546
General Purpose Tooth Kit (Includes 100 #18546 Teeth)	107013

#3 DESCRIPTION	<u>PART NUMBER</u>
Concrete Application Pick with Washer	18547
Concrete Tooth Kit (Includes 100 #18547 Teeth)	107012

WHEEL ASSEMBLY

ASSEMBLY #18702

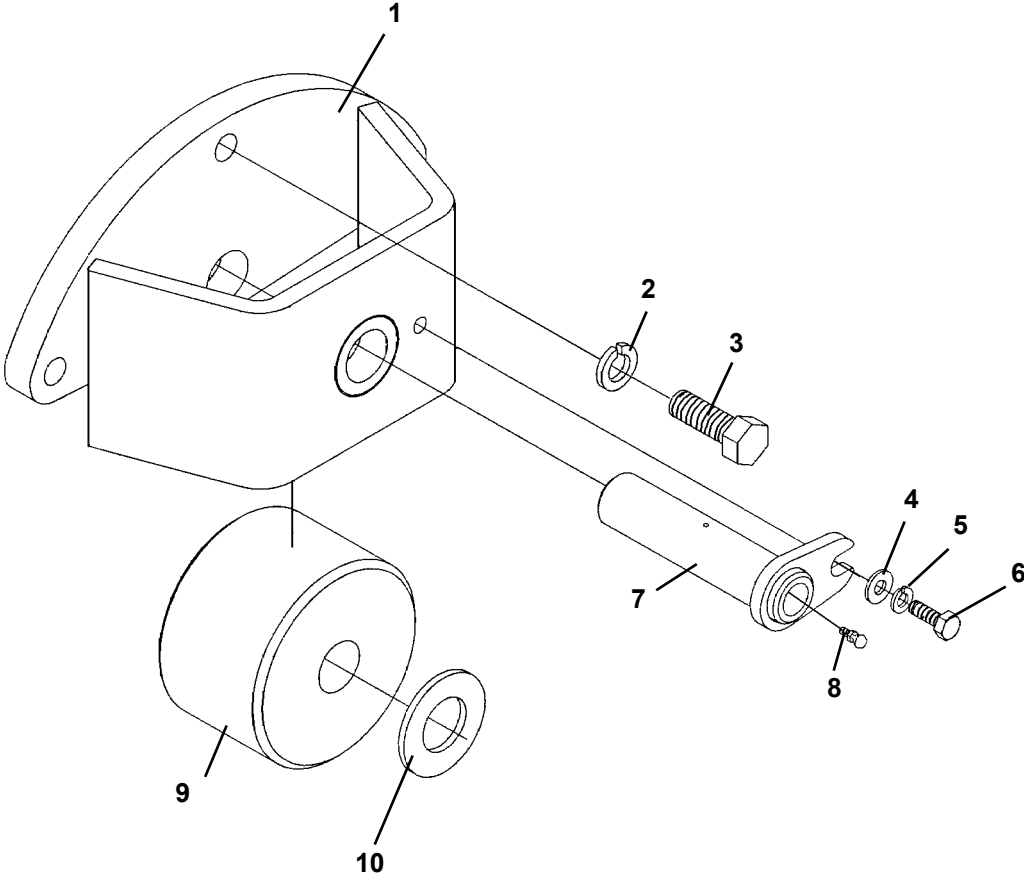

WHEEL ASSEMBLY

ASSEMBLY #18702

<u>ITEM</u>	<u>REQ'D</u>	<u>PART NO.</u>	<u>DESCRIPTION</u>
1	1	17667	Wheel Mounting Bracket
2	3	1505	.50" Lock Washer
3	3	1811	.50" UNC X 1.50" Hex Capscrew - Grade 8
4	1	1514	.38" Flat Washer
5	1	1503	.38" Lock Washer
6	1	1042	.38 "UNC X .75" Hex Capscrew
7	1	17673	Pivot Pin
8	1	6616	Grease Fitting
9	1	17671	Wheel
10	1	61079	Washer

9359 7-30-07-2

HYDRAULIC ASSEMBLY

ASSEMBLY #19220

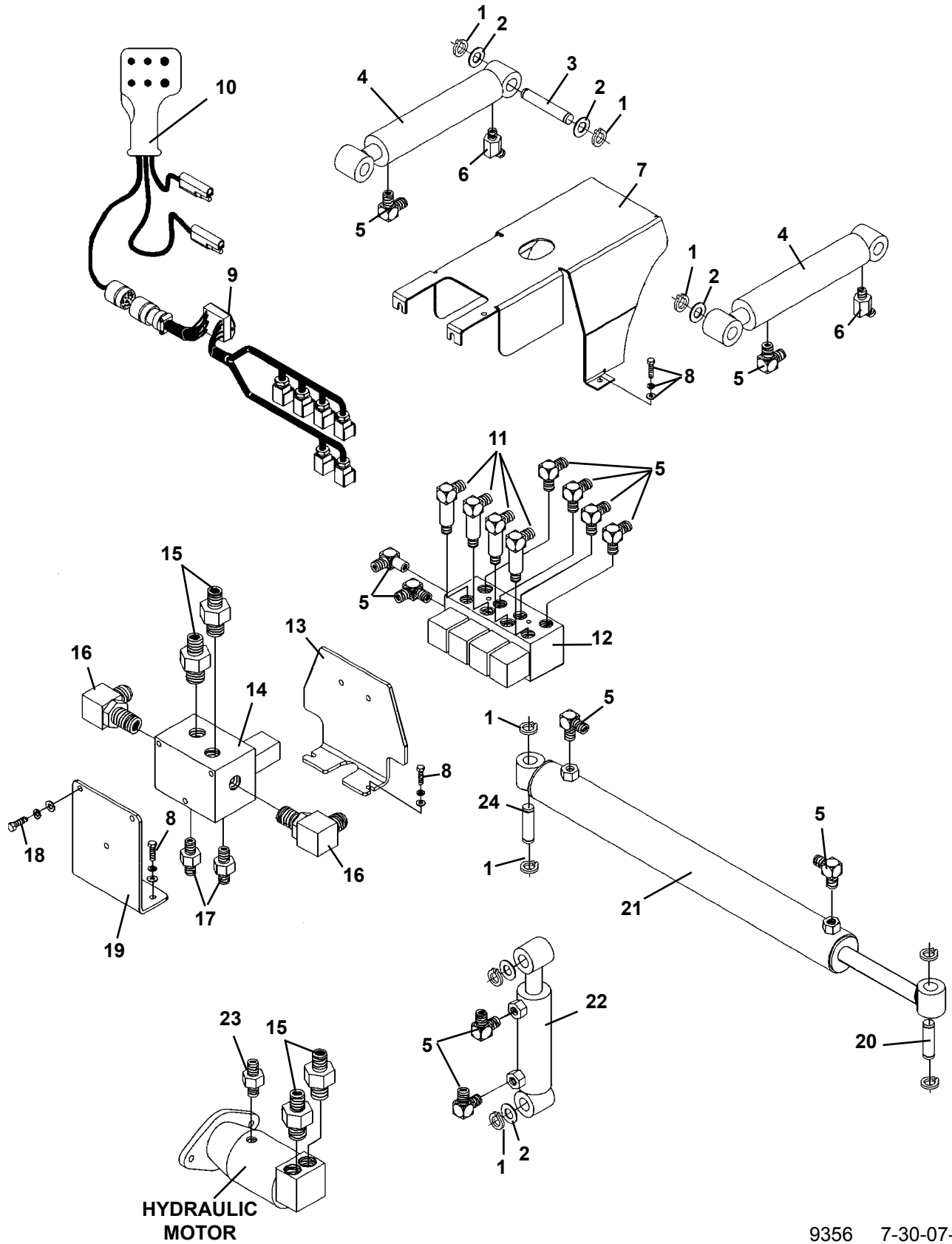

9356 7-30-07-2

HYDRAULIC ASSEMBLY

ASSEMBLY #19220

<u>ITEM</u>	<u>REQ'D</u>	<u>PART NO.</u>	<u>DESCRIPTION</u>
1	12	6612	Snap Ring 1.00"
2	8	61079	Thrust Washer 1.00" x .06"
3	2	73461	Cylinder Pin
4	2	89520	Cylinder Assembly (Depth Control)
5	12	3434	90° Elbow 6MBo-6MJ
6	2	30313	45° Elbow 6MBo-6MJ
7	1	19195	Valve Cover
8	6	1022	.31" UNC X 1.00" Hex Capscrew
	6	1502	.31" Lock Washer
	6	1513	.31" Flat Washer
9	1	19215	Wire Harness - Four Function Control
	2	1836	10-24 UNC Hex Nut
	2	1634	10-24 X .50" Round Headed Capscrew
10	1	100434	Electrical Control Handle
11	4	30140	90° Elbow - XL 6MBo-6MJ
12	1	89618	Cylinder Control Valve
	2	1033	.31" UNC X 3.75" Hex Capscrew
	2	1502	.31" Lock Washer
	2	1513	.31" Flat Washer
13	1	19970	Bracket
14	1	100780	Control Valve
15	4	3409	Straight Connector 16MBo-12MJ
16	2	30051	90° Elbow 16MBo-12MJ
17	2	3457	Straight Connector 6MBo-6MJ
18	3	1043	.38" UNC X 1.00" Hex Capscrew
	3	1503	.38" Lock Washer
	3	1800	.38" Hard Flat Washer
19	1	19194	Valve Mounting Bracket
20	1	89978	Cylinder Pin
21	1	89535	Cylinder Assembly (Side Shift)
22	1	101540	Cylinder Assembly (Tilt - 24", 30" & 40" Planers)
	1	89530	Cylinder Assembly (Tilt - 16" & 18" Planers)
23	1	3269	Straight Connector 8MBo-6MJ
24	1	102537	Cylinder Pin

9357 7-30-07-2

HP400 & HP450 PLANER HOSE KIT

16" & 18" PLANER HOSE SET #38168

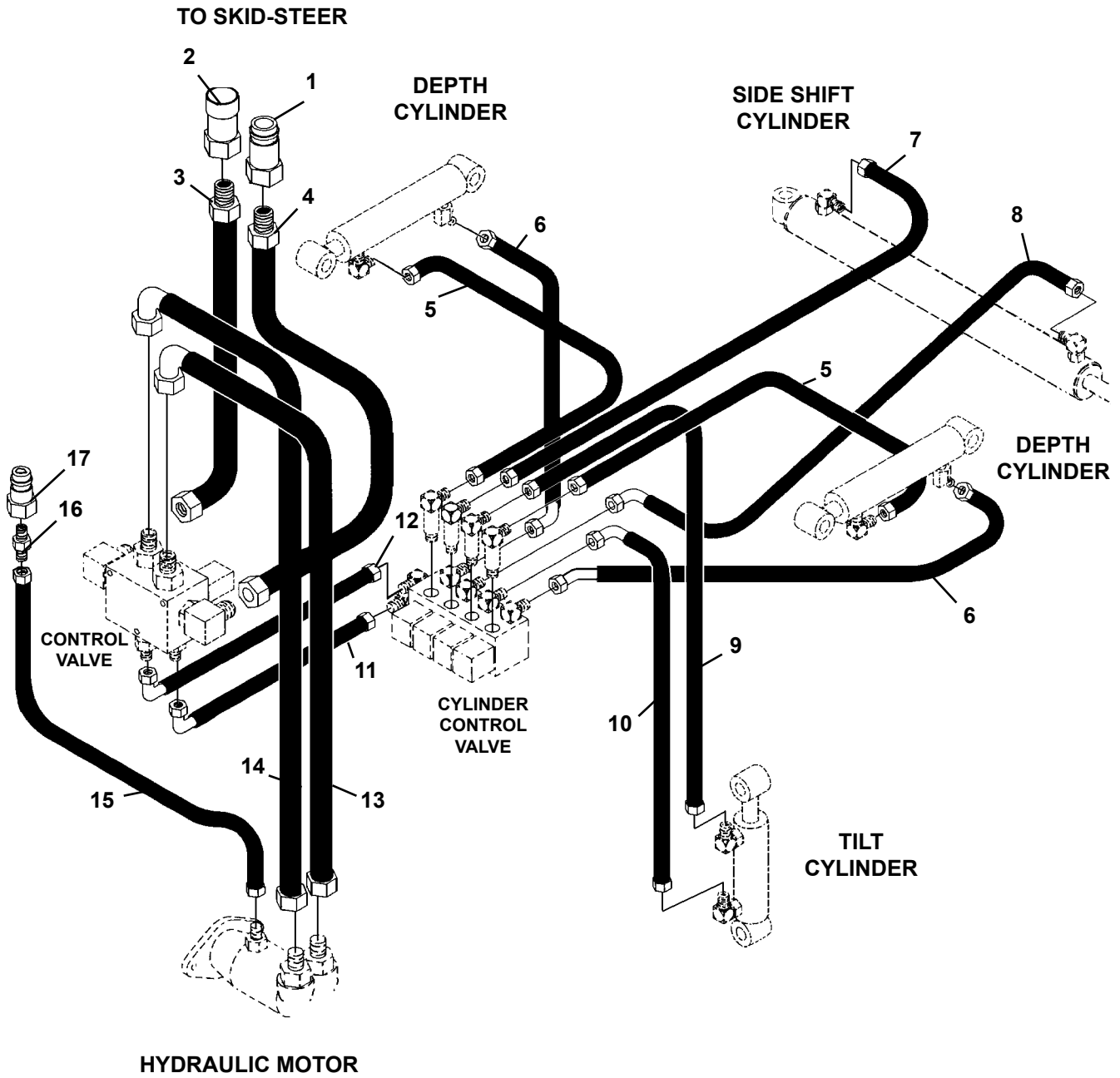

HP400 & HP450 PLANER HOSE KIT

16" & 18" PLANER HOSE SET #38168

<u>ITEM</u>	<u>REQ'D</u>	<u>PART NO.</u>	<u>DESCRIPTION</u>
1	1	19638	Male Coupler
2	1	22520	Female Coupler
3	1	38159	Hose .75" X 75" 12FJX-12MBo-HS
4	1	38159	Hose .75" X 75" 12FJX-12MBo-HS
5	2	37016	Hose .25" X 15" 6FJX-6FJX
6	2	38175	Hose .25" X 17" 6FJX-6FJX 45°
7	1	37599	Hose .25" X 66" 6FJX-6FJX
8	1	38108	Hose .25" X 54" 6FJX-6FJX 90°
9	1	37236	Hose .25" X 22" 6FJX-6FJX
10	1	38106	Hose .25" X 22" 6FJX-6FJX 90°
11	1	38360	Hose .25" X 13" 6FJX-6FJX 90°
12	1	38021	Hose .25" X 16" 6FJX-6FJX 90°
13	1	38174	Hose .75" X 38" 12FJX-12FJX 90° -HS
14	1	38109	Hose .75" X 39" 12FJX-12FJX 90° -HS
15	1	37275	Hose .25" X 94" 6FJX-6FJX
16	1	3269	Straight Connector 8MBo-6MJ
17	1	84923	Male Coupler

HP600 PLANER HOSE KIT

24" PLANER HOSE SET #38169

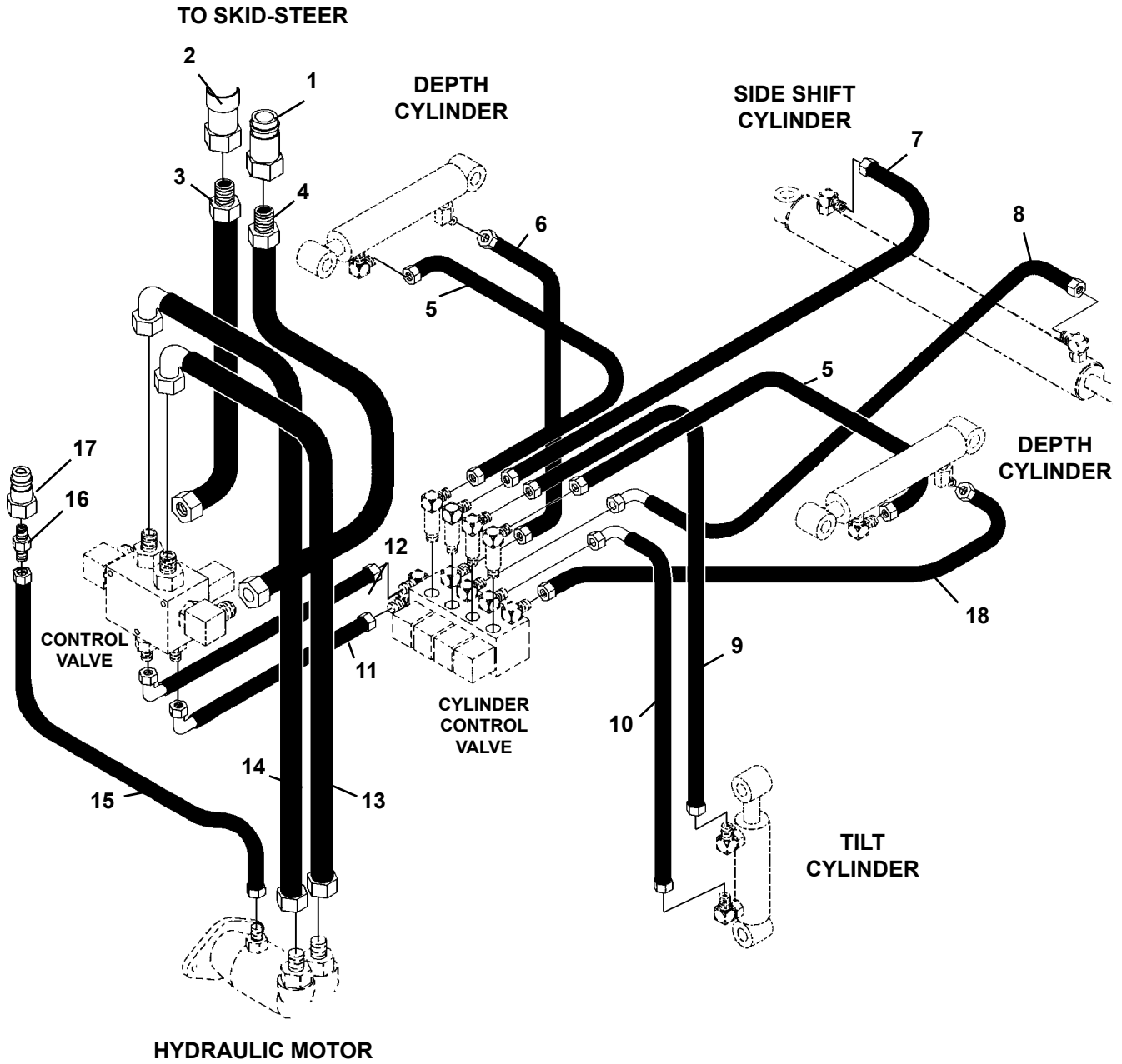

HP600 PLANER HOSE KIT

24" PLANER HOSE SET #38169

<u>ITEM</u>	<u>REQ'D</u>	<u>PART NO.</u>	<u>DESCRIPTION</u>
1	1	19638	Male Coupler
2	1	22520	Female Coupler
3	1	38159	Hose .75" X 75" 12FJX-12MBo-HS
4	1	38159	Hose .75" X 75" 12FJX-12MBo-HS
5	2	37017	Hose .25" X 21" 6FJX-6FJX
6	1	37017	Hose .25" X 21" 6FJX-6FJX
7	1	37599	Hose .25" X 66" 6FJX-6FJX
8	1	38108	Hose .25" X 54" 6FJX-6FJX 90°
9	1	37421	Hose .25" X 25" 6FJX-6FJX
10	1	37804	Hose .25" X 25" 6FJX-6FJX 90°
11	1	38360	Hose .25" X 13" 6FJX-6FJX 90°
12	1	38021	Hose .25" X 16" 6FJX-6FJX 90°
13	1	38174	Hose .75" X 38" 12FJX-12FJX 90° -HS
14	1	38109	Hose .75" X 39" 12FJX-12FJX 90° -HS
15	1	37275	Hose .25" X 94" 6FJX-6FJX
16	1	3269	Straight Connector 8MBo-6MJ
17	1	84923	Male Coupler
18	1	37017	Hose .25" X 21" 6FJX-6FJX

HP750 PLANER HOSE KIT

30" PLANER HOSE SET #38170

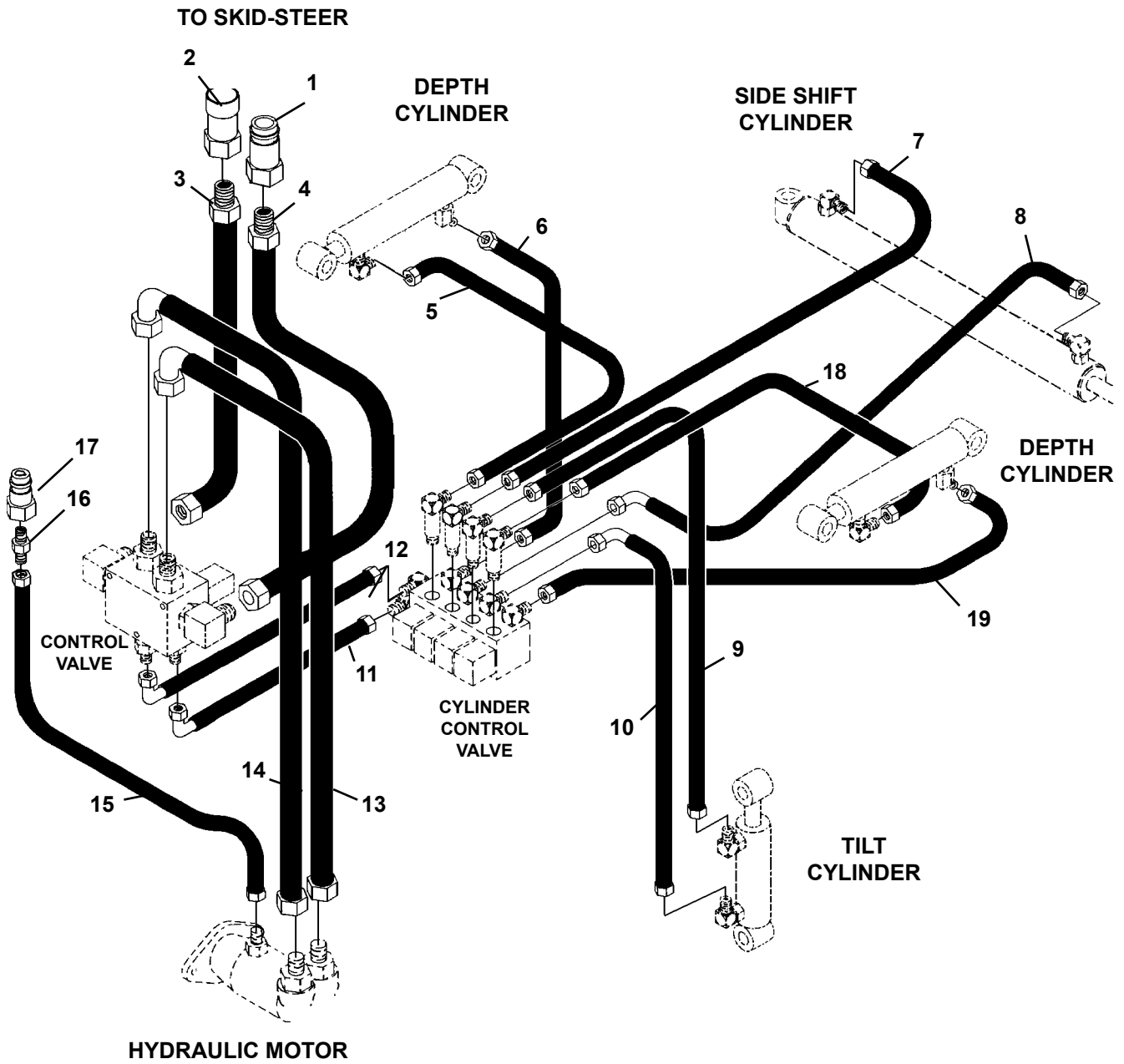

HP750 PLANER HOSE KIT

30" PLANER HOSE SET #381670

<u>ITEM</u>	<u>REQ'D</u>	<u>PART NO.</u>	<u>DESCRIPTION</u>
1	1	19638	Male Coupler
2	1	22520	Female Coupler
3	1	38159	Hose .75" X 75" 12FJX-12MBo-HS
4	1	38159	Hose .75" X 75" 12FJX-12MBo-HS
5	1	37282	Hose .25" X 24" 6FJX-6FJX
6	1	38107	Hose .25" X 17" 6FJX-6FJX
7	1	37599	Hose .25" X 66" 6FJX-6FJX
8	1	38108	Hose .25" X 54" 6FJX-6FJX 90°
9	1	35694	Hose .25" X 34" 6FJX-6FJX
10	1	37805	Hose .25" X 34" 6FJX-6FJX 90°
11	1	38360	Hose .25" X 13" 6FJX-6FJX 90°
12	1	38021	Hose .25" X 16" 6FJX-6FJX 90°
13	1	38158	Hose .75" X 41" 12FJX-12FJX 90° -HS
14	1	37658	Hose .75" X 42" 12FJX-12FJX 90° -HS
15	1	37275	Hose .25" X 94" 6FJX-6FJX
16	1	3269	Straight Connector 8MBo-6MJ
17	1	84923	Male Coupler
18	1	37236	Hose .25" X 22" 6FJX-6FJX
19	1	37484	Hose .25" X 16" 6FJX-6FJX

HP1000 PLANER HOSE KIT

40" PLANER HOSE SET #38308

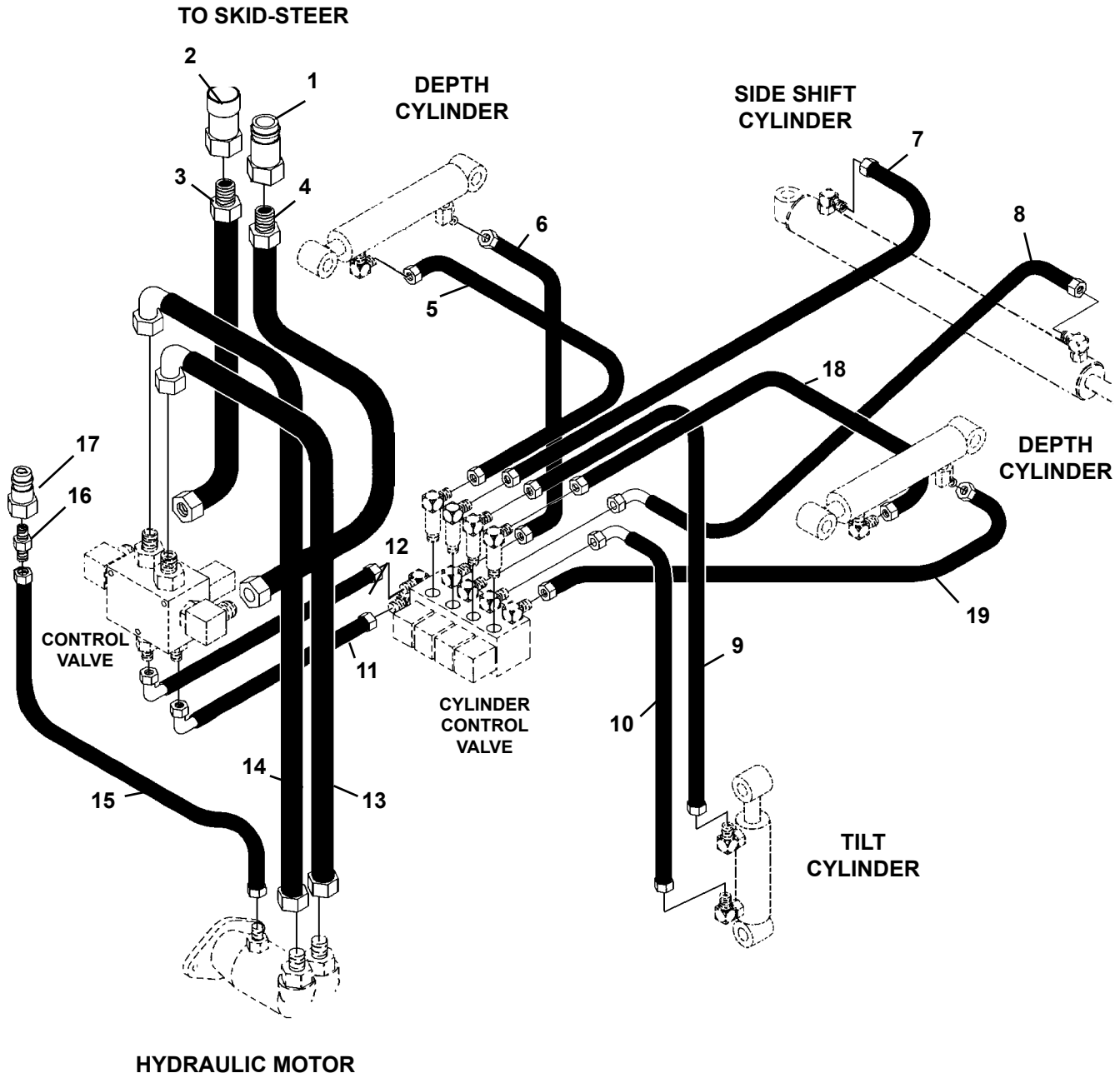

HP1000 PLANER HOSE KIT

40" PLANER HOSE SET #38308

<u>ITEM</u>	<u>REQ'D</u>	<u>PART NO.</u>	<u>DESCRIPTION</u>
1	1	19638	Male Coupler
2	1	22520	Female Coupler
3	1	38159	Hose .75" X 75" 12FJX-12MBo-HS
4	1	38159	Hose .75" X 75" 12FJX-12MBo-HS
5	1	35694	Hose .25" X 34" 6FJX-6FJX
6	1	38217	Hose .25" X 27" 6FJX-6FJX
7	1	37599	Hose .25" X 66" 6FJX-6FJX
8	1	38108	Hose .25" X 54" 6FJX-6FJX 90°
9	1	35694	Hose .25" X 34" 6FJX-6FJX
10	1	37805	Hose .25" X 34" 6FJX-6FJX 90°
11	1	38360	Hose .25" X 13" 6FJX-6FJX 90°
12	1	38021	Hose .25" X 16" 6FJX-6FJX 90°
13	1	38158	Hose .75" X 41" 12FJX-12FJX 90° -HS
14	1	37658	Hose .75" X 42" 12FJX-12FJX 90° -HS
15	1	37275	Hose .25" X 94" 6FJX-6FJX
16	1	3269	Straight Connector 8MBo-6MJ
17	1	84923	Male Coupler
18	1	37236	Hose .25" X 22" 6FJX-6FJX
19	1	37484	Hose .25" X 16" 6FJX-6FJX

10429 7-30-07-2

WATER NOZZLE KIT

ASSEMBLY #19216

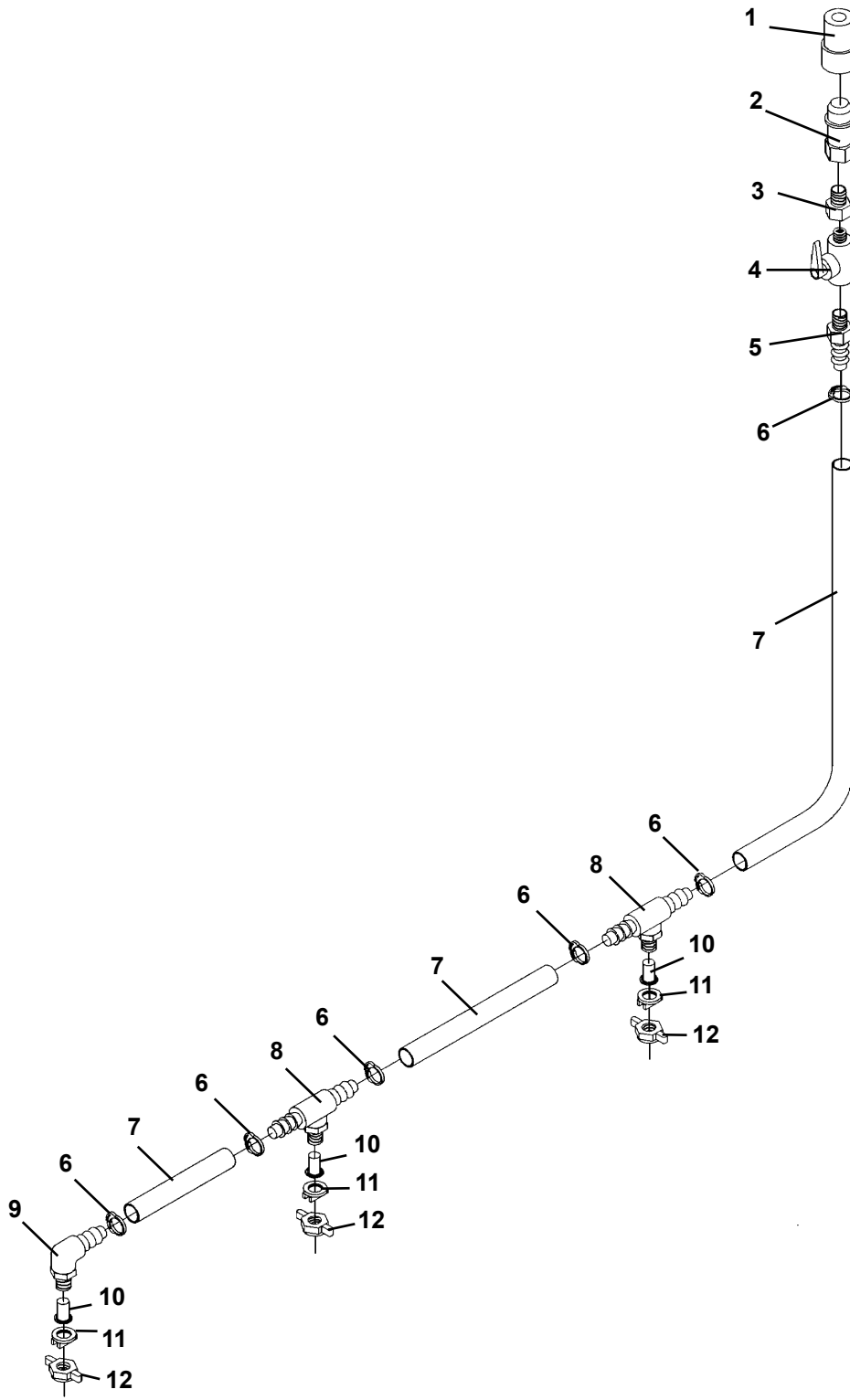

WATER NOZZLE KIT

ASSEMBLY #19216

<u>ITEM</u>	<u>REQ'D</u>	<u>PART NO.</u>	<u>DESCRIPTION</u>
1	1	30215	Female Quick Coupler
2	1	30214	Male Quick Coupler
3	1	30338	Bushing
4	1	30231	Ball Valve
5	1	30216	Hose Barb
6	6	30227	Hose Clamp
7	14'	19217	Reinforced PVC Hose (Cut to Length)
8	2	30223	Tee Nozzlebody
9	1	30222	90° Nozzlebody
10	3	30221	Inline Nozzlebody Strainer
11	3	30229	Spray Nozzle Tip
12	3	30225	Nozzlebody Wing Cap

WATER NOZZLE KIT

ASSEMBLY #103031

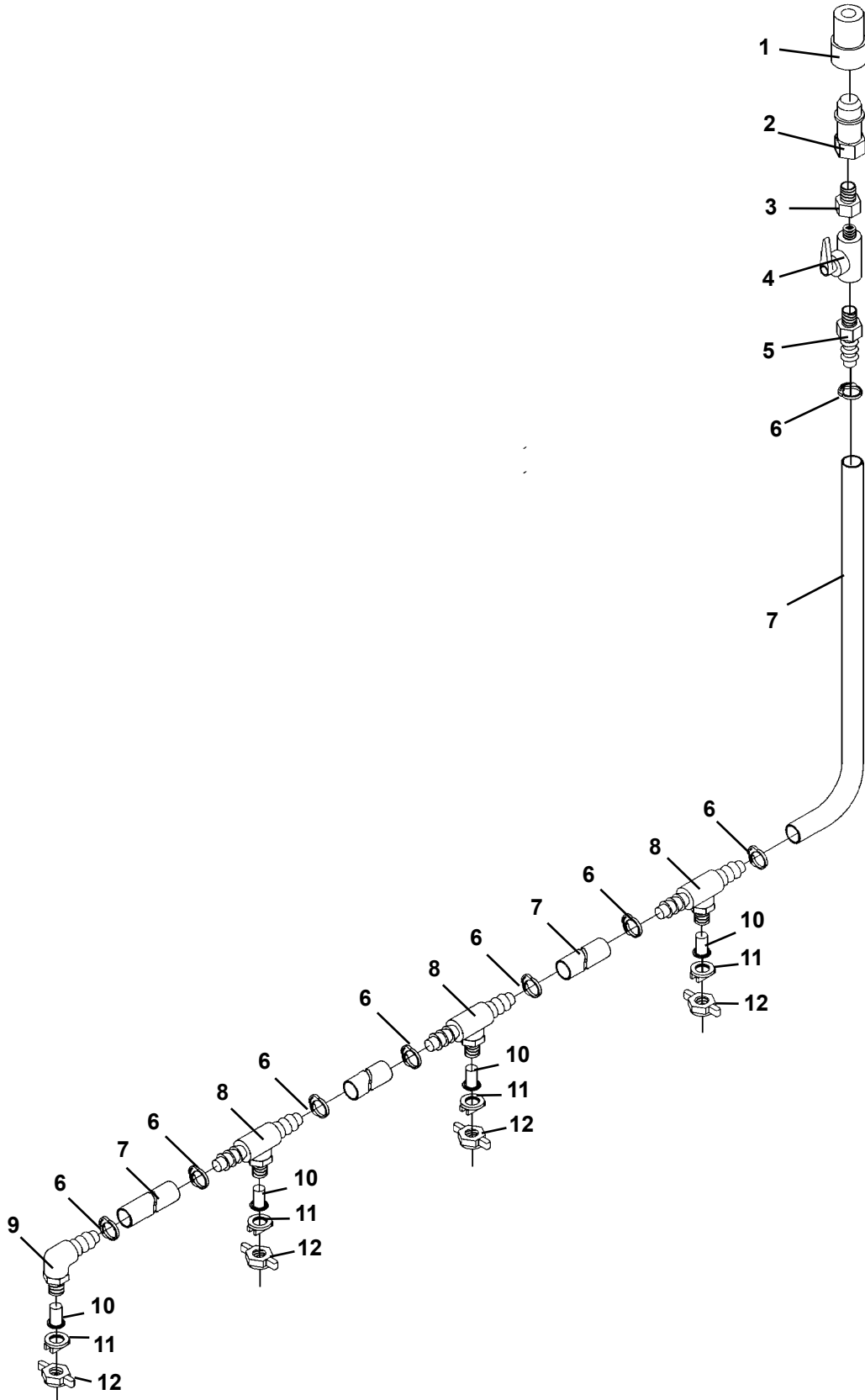

10430 7-30-07-2

WATER NOZZLE KIT

ASSEMBLY #103031

<u>ITEM</u>	<u>REQ'D</u>	<u>PART NO.</u>	<u>DESCRIPTION</u>
1	1	30215	Female Quick Coupler
2	1	30214	Male Quick Coupler
3	1	30338	Bushing
4	1	30231	Ball Valve
5	1	30216	Hose Barb
6	8	30227	Hose Clamp
7	15'	36296	Reinforced PVC Hose (Cut to Length)
8	3	30223	Tee Nozzlebody
9	1	30222	90° Nozzlebody
10	4	30221	Inline Nozzlebody Strainer
11	4	30229	Spray Nozzle Tip
12	4	30225	Nozzlebody Wing Cap

CYLINDER ASSEMBLY

ASSEMBLY #101540

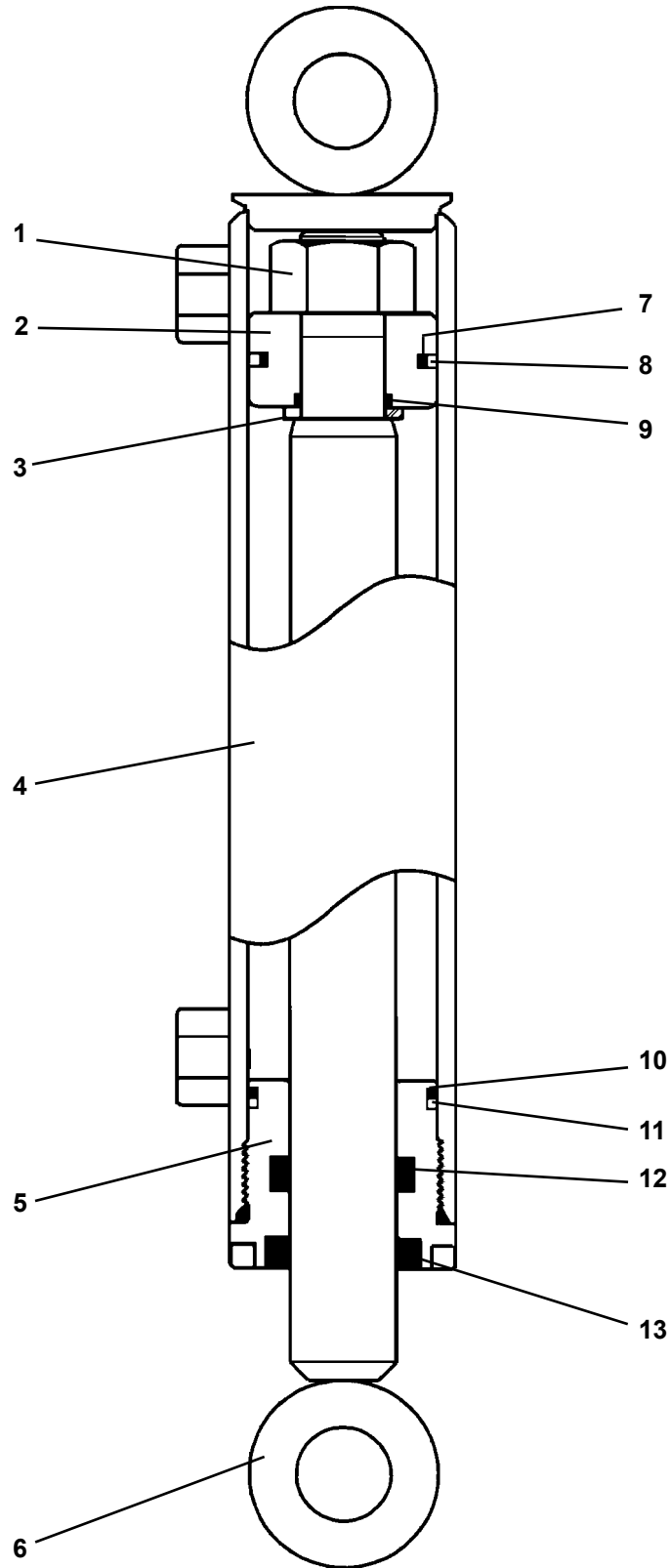

CYLINDER ASSEMBLY

ASSEMBLY #101540

<u>ITEM</u>	<u>REQ'D</u>	<u>PART NO.</u>	<u>DESCRIPTION</u>
1	1	1482	Hex Nut
2	1	6992	Piston
3	1	52644	Washer
4	1	101539	Cylinder Tube
5	1	89527	Cylinder Gland
6	1	101537	Cylinder Rod
7	1	4637*	O-Ring
8	1	4636*	Piston Ring
9	1	4635*	O-Ring
10	1	4633*	O-Ring
11	1	4634*	Back-Up Washer
12	1	45262*	Poly-Pak Seal
13	1	4981*	Rod Wiper

NOTE: Seal kit #45581 includes all parts marked with an asterisk (*). Parts are not sold separately.

9830 7-30-07-2

CYLINDER ASSEMBLY

ASSEMBLY #89530

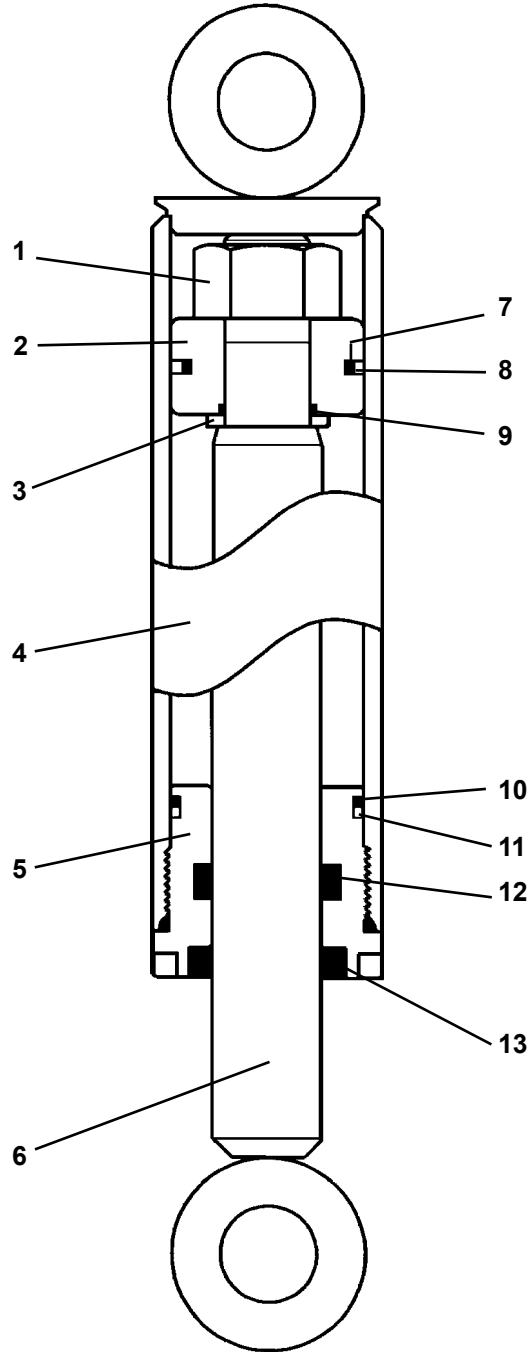

CYLINDER ASSEMBLY

ASSEMBLY #89530

<u>ITEM</u>	<u>REQ'D</u>	<u>PART NO.</u>	<u>DESCRIPTION</u>
1	1	1482	Hex Nut
2	1	6992	Piston
3	1	52644	Washer
4	1	89531	Cylinder Tube
5	1	89527	Cylinder Gland
6	1	89532	Cylinder Rod
7	1	4637*	O-Ring
8	1	4636*	Piston Ring
9	1	4635*	O-Ring
10	1	4633*	O-Ring
11	1	4634*	Back-Up Washer
12	1	45262*	Poly-Pak Seal
13	1	4981*	Rod Wiper

NOTE: Seal kit #45581 includes all parts marked with an asterisk (*). Parts are not sold separately.

9361 7-30-07-2

CYLINDER ASSEMBLY

ASSEMBLY #89520

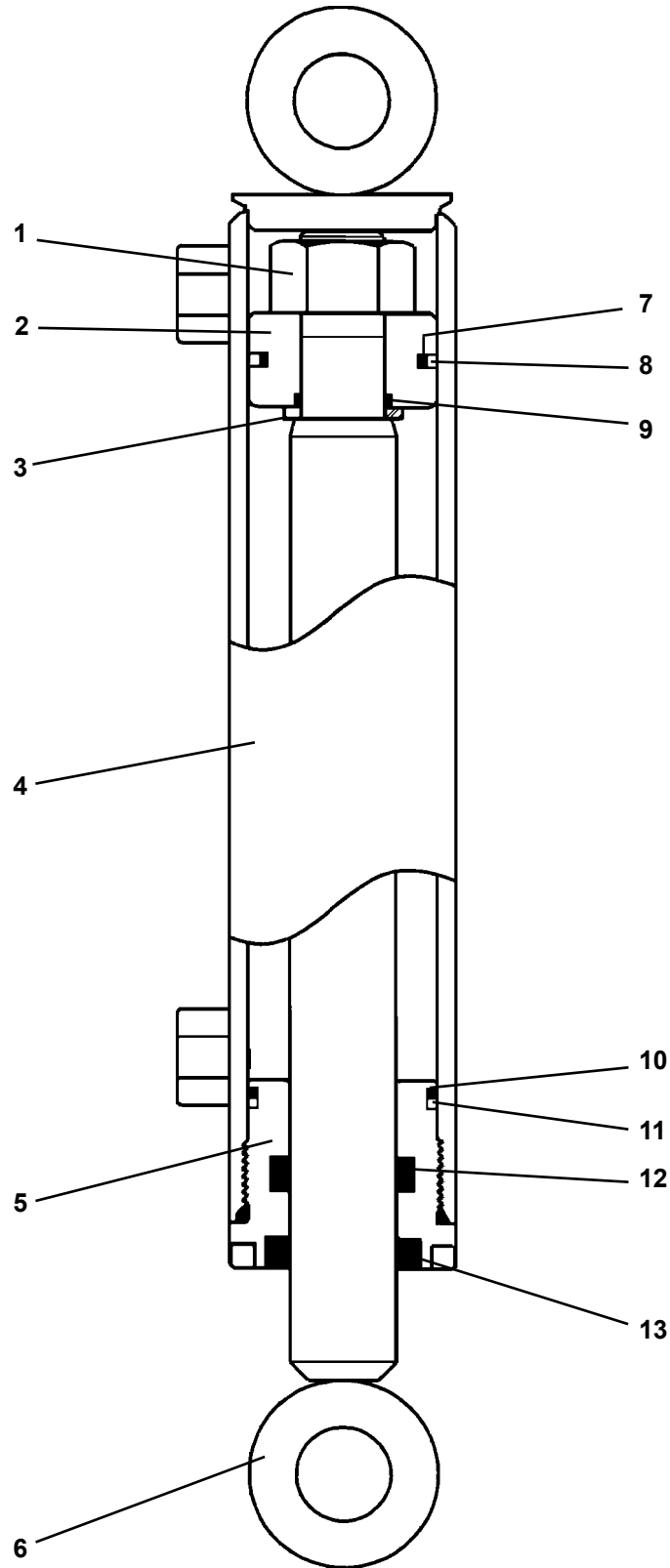

CYLINDER ASSEMBLY

ASSEMBLY #89520

<u>ITEM</u>	<u>REQ'D</u>	<u>PART NO.</u>	<u>DESCRIPTION</u>
1	1	1482	Hex Nut
2	1	6992	Piston
3	1	52644	Washer
4	1	89521	Cylinder Tube
5	1	89527	Cylinder Gland
6	1	89522	Cylinder Rod
7	1	4637*	O-Ring
8	1	4636*	Piston Ring
9	1	4635*	O-Ring
10	1	4633*	O-Ring
11	1	4634*	Back-Up Washer
12	1	45262*	Poly-Pak Seal
13	1	4981*	Rod Wiper

NOTE: Seal kit #45581 includes all parts marked with an asterisk (*). Parts are not sold separately.

9363 7-30-07-2

CYLINDER ASSEMBLY

ASSEMBLY #89535

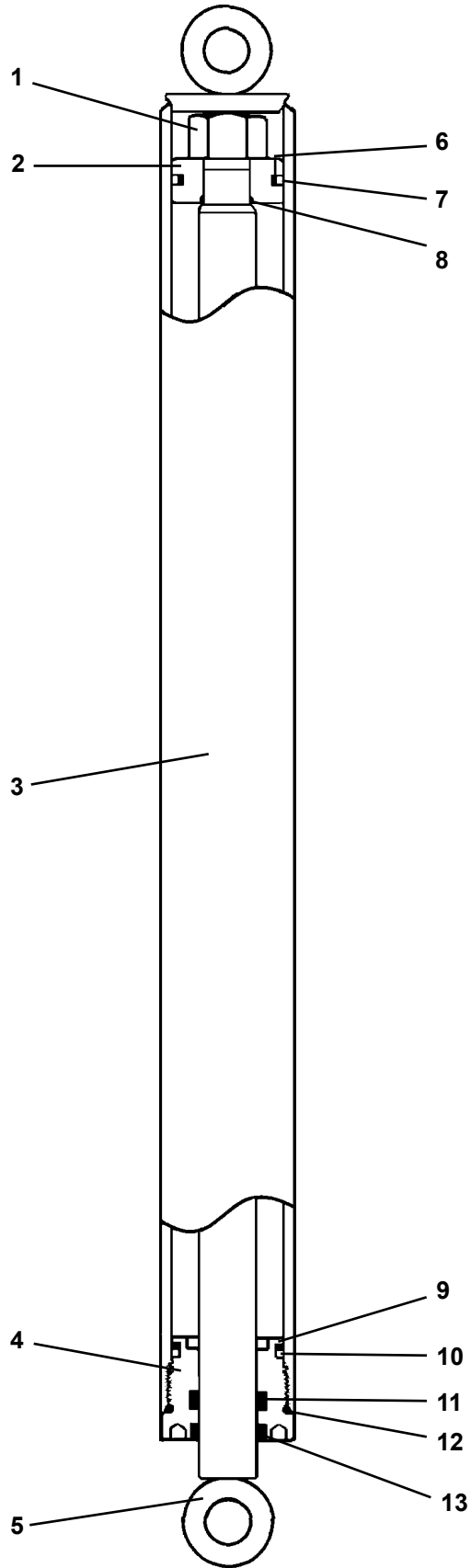

CYLINDER ASSEMBLY

ASSEMBLY #89535

<u>ITEM</u>	<u>REQ'D</u>	<u>PART NO.</u>	<u>DESCRIPTION</u>
1	1	1483	Hex Nut
2	1	50252	Piston
3	1	89536	Cylinder Tube
4	1	86609	Cylinder Gland
5	1	89537	Cylinder Rod
6	1	4645*	O-Ring
7	1	4644*	Piston Ring
8	1	4641*	O-Ring
9	1	4509*	O-Ring
10	1	4510*	Back-Up Washer
11	1	45225*	Poly-Pak Seal
12	1	45250*	O-Ring
13	1	45372*	Rod Wiper

NOTE: Seal kit #45738 includes all parts marked with an asterisk (*). Parts are not sold separately.

9365 7-30-07-2