



OPERATOR'S AND PARTS MANUAL

RS18 & RS24 ROCK SAW



PALADIN LIGHT CONSTRUCTION



SERIAL NUMBER: _____

MODEL NUMBER: _____

Manual Number: OM689
Part Number: 75589
Rev.

TABLE OF CONTENTS

PREFACE	3
SAFETY PRECAUTIONS	
SAFETY STATEMENTS	5
GENERAL SAFETY PRECAUTIONS	5-7
EQUIPMENT SAFETY PRECAUTIONS	8
DECALS	
DECAL PLACEMENT	9
DECALS	10-11
INSTALLATION	12-13
OPERATING INSTRUCTIONS	
ROCK SAW OPERATION	14-16
STORAGE & TRANSPORTING	16
MAINTENANCE AND SERVICE	
GENERAL MAINTENANCE	17
LUBRICATION	17
PICK REPLACEMENT	18
PICK AND HOLDER REPLACEMENT	19
HYDRAULIC MOTOR REPLACEMENT OR REPAIR	19-20
PLANETARY REPLACEMENT OR REPAIR	20-23
CHANGING PLANETARY OIL	23
CYLINDER SEAL REPLACEMENT	24-25
TROUBLESHOOTING	26-27
SPECIFICATIONS	
BOLT TORQUE SPECIFICATIONS	28
TREE SPADE SPECIFICATIONS	29
LIMITED WARRANTY	31
PARTS	
ROCK SAW ASSEMBLIES (MAINFRAME)	32-33
ROCK SAW ASSEMBLIES (SIDE SHIFT FRAME)	34-35
ROCK SAW ASSEMBLIES (HYDRAULICS)	36-37
ROCK SAW ASSEMBLIES (HYDRAULIC HOSES)	38-39
PICK AND HOLDER ASSEMBLIES	40-41
POWER AND RETURN HYDRAULIC KITS	42-43
CYLINDER ASSEMBLY #106420	44-45
CYLINDER ASSEMBLY #105966	46-47
ELECTRICAL CONTROL HANDLE ASSEMBLY #104367	48
ELECTRICAL WIRE HARNESS ASSEMBLY #101096	49
CONTROL BOX #104368 (USE WITH HARNESS #101096)	50

PREFACE

GENERAL COMMENTS

Congratulations on the purchase of your new BRADCO product! This product was carefully designed and manufactured to give you many years of dependable service. Only minor maintenance (such as cleaning and lubricating) is required to keep it in top working condition. Be sure to observe all maintenance procedures and safety precautions in this manual and on any safety decals located on the product and on any equipment on which the attachment is mounted.

This manual has been designed to help you do a better, safer job. Read this manual carefully and become familiar with its contents.

WARNING!  Never let anyone operate this unit without reading the "Safety Precautions" and "Operating Instructions" sections of this manual. Always choose hard, level ground to park the vehicle on and set the brake so the unit cannot roll.

Unless noted otherwise, right and left sides are determined from the operator's control position when facing the attachment.

NOTE: The illustrations and data used in this manual were current (according to the information available to us) at the time of printing, however, we reserve the right to redesign and change the attachment as may be necessary without notification.

BEFORE OPERATION

The primary responsibility for safety with this equipment falls to the operator. Make sure the equipment is operated only by trained individuals that have read and understand this manual. If there is any portion of this manual or function you do not understand, contact your local authorized dealer or the manufacturer.

SAFETY ALERT SYMBOL



This is the "Safety Alert Symbol" used by this industry. This symbol is used to warn of possible injury. Be sure to read all warnings carefully. They are included for your safety and for the safety of others working with you.

SERVICE

When servicing your product, remember to use only manufacturer replacement parts. Substitute parts may not meet the standards required for safe, dependable operation.

To facilitate parts ordering, record the model and serial number of your unit in the space provided on the cover of this manual. This information may be obtained from the identification plate located on the product.

The parts department needs this information to insure that you receive the correct parts for your specific model.

SAFETY STATEMENTS



THIS SYMBOL BY ITSELF OR WITH A WARNING WORD THROUGHOUT THIS MANUAL IS USED TO CALL YOUR ATTENTION TO INSTRUCTIONS INVOLVING YOUR PERSONAL SAFETY OR THE SAFETY OF OTHERS. FAILURE TO FOLLOW THESE INSTRUCTIONS CAN RESULT IN INJURY OR DEATH.



DANGER

THIS SIGNAL WORD IS USED WHERE SERIOUS INJURY OR DEATH WILL RESULT IF THE INSTRUCTIONS ARE NOT FOLLOWED PROPERLY.



WARNING

THIS SIGNAL WORD IS USED WHERE SERIOUS INJURY OR DEATH COULD RESULT IF THE INSTRUCTIONS ARE NOT FOLLOWED PROPERLY.



CAUTION

THIS SIGNAL WORD IS USED WHERE MINOR INJURY COULD RESULT IF THE INSTRUCTIONS ARE NOT FOLLOWED PROPERLY.

NOTICE

NOTICE INDICATES A PROPERTY DAMAGE MESSAGE.

GENERAL SAFETY PRECAUTIONS

WARNING!

READ MANUAL PRIOR TO INSTALLATION



Improper installation, operation, or maintenance of this equipment could result in serious injury or death. Operators and maintenance personnel should read this manual, as well as all manuals related to this equipment and the prime mover thoroughly before beginning installation, operation, or maintenance. **FOLLOW ALL SAFETY INSTRUCTIONS IN THIS MANUAL AND THE PRIME MOVER'S MANUAL(S).**



READ AND UNDERSTAND ALL SAFETY STATEMENTS

Read all safety decals and safety statements in all manuals prior to operating or working on this equipment. Know and obey all OSHA regulations, local laws, and other professional guidelines for your operation. Know and follow good work practices when assembling, maintaining, repairing, mounting, removing, or operating this equipment.



KNOW YOUR EQUIPMENT

Know your equipment's capabilities, dimensions, and operations before operating. Visually inspect your equipment before you start, and never operate equipment that is not in proper working order with all safety devices intact. Check all hardware to ensure it is tight. Make certain that all locking pins, latches, and connection devices are properly installed and secured. Remove and replace any damaged, fatigued, or excessively worn parts. Make certain all safety decals are in place and are legible. Keep decals clean, and replace them if they become worn or hard to read.

GENERAL SAFETY PRECAUTIONS

WARNING!



PROTECT AGAINST FLYING DEBRIS

Always wear proper safety glasses, goggles, or a face shield when driving pins in or out, or when any operation causes dust, flying debris, or any other hazardous material.

WARNING!



LOWER OR SUPPORT RAISED EQUIPMENT

Do not work under raised booms without supporting them. Do not use support material made of concrete blocks, logs, buckets, barrels, or any other material that could suddenly collapse or shift positions. Make sure support material is solid, not decayed, warped, twisted, or tapered. Lower booms to ground level or on blocks. Lower booms and attachments to the ground before leaving the cab or operator's station.

WARNING!



USE CARE WITH HYDRAULIC FLUID PRESSURE

Hydraulic fluid under pressure can penetrate the skin and cause serious injury or death. Hydraulic leaks under pressure may not be visible. Before connecting or disconnecting hydraulic hoses, read your prime mover's operator's manual for detailed instructions on connecting and disconnecting hydraulic hoses or fittings.

- Keep unprotected body parts, such as face, eyes, and arms as far away as possible from a suspected leak. Flesh injected with hydraulic fluid may develop gangrene or other permanent disabilities.
- If injured by injected fluid, see a doctor at once. If your doctor is not familiar with this type of injury, ask him to research it immediately to determine proper treatment.
- Wear safety glasses, protective clothing, and use a piece of cardboard or wood when searching for hydraulic leaks. **DO NOT USE YOUR HANDS!** **SEE ILLUSTRATION.**

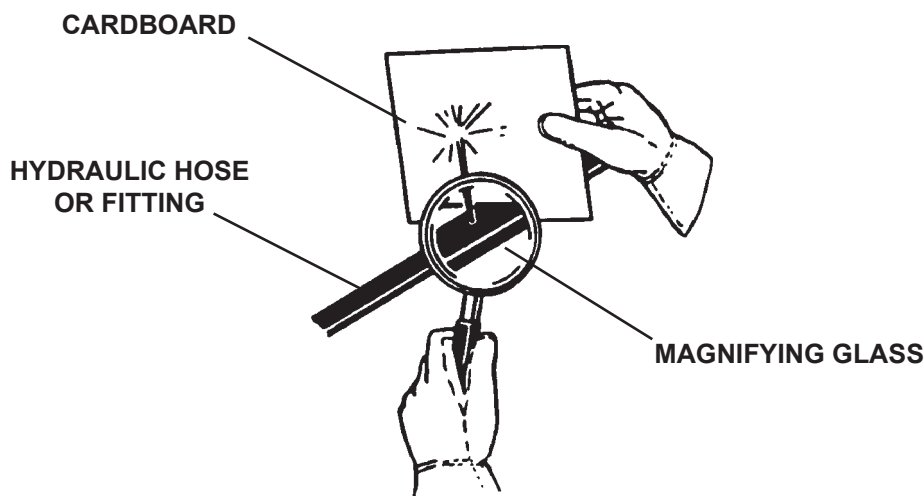

GENERAL SAFETY PRECAUTIONS

WARNING!



DO NOT MODIFY MACHINE OR ATTACHMENTS

Modifications may weaken the integrity of the attachment and may impair the function, safety, life, and performance of the attachment. When making repairs, use only the manufacturer's genuine parts, following authorized instructions. Other parts may be substandard in fit and quality. Never modify any ROPS (Roll Over Protection Structure) or FOPS (Falling Object Protective Structure) equipment or device. Any modifications must be authorized in writing by the manufacturer.

WARNING!



SAFELY MAINTAIN AND REPAIR EQUIPMENT

- Do not wear loose clothing or any accessories that can catch in moving parts. If you have long hair, cover or secure it so that it does not become entangled in the equipment.
- Work on a level surface in a well-lit area.
- Use properly grounded electrical outlets and tools.
- Use the correct tools for the job at hand. Make sure they are in good condition for the task required.
- Wear the protective equipment specified by the tool manufacturer.



SAFELY OPERATE EQUIPMENT

Do not operate equipment until you are completely trained by a qualified operator in how to use the controls, know its capabilities, dimensions, and all safety requirements. See your machine's manual for these instructions.

- Keep all step plates, grab bars, pedals, and controls free of dirt, grease, debris, and oil.
- Never allow anyone to be around the equipment when it is operating.
- Do not allow riders on the attachment or the prime mover.
- Do not operate the equipment from anywhere other than the correct operator's position.
- Never leave equipment unattended with the engine running, or with this attachment in a raised position.
- Do not alter or remove any safety feature from the prime mover or this attachment.
- Know your work site safety rules as well as traffic rules and flow. When in doubt on any safety issue, contact your supervisor or safety coordinator for an explanation.

EQUIPMENT SAFETY PRECAUTIONS

WARNING!



KNOW WHERE UTILITIES ARE

Observe overhead electrical and other utility lines. Be sure equipment will clear them. When digging, call your local utilities for location of buried utility lines, gas, water, and sewer, as well as any other hazard you may encounter.



OPERATING THE ROCK SAW

- Block off work area from bystanders, livestock, etc.
- Operate only from the operator's station.
- When operating on slopes, drive up and down, not across. Avoid steep hillside operation, which could cause the prime mover to overturn.
- Reduce speed when driving over rough terrain, on a slope, or turning, to avoid overturning the vehicle.
- An operator must not use drugs or alcohol, which can change his or her alertness or coordination. An operator taking prescription or over-the-counter drugs should seek medical advice on whether or not he or she can safely operate equipment.
- Before exiting the prime mover, lower the attachment to the ground, turn off the prime mover's engine, remove the key and apply the brakes.
- Be sure all doors, guards and shields are in their proper position and securely attached before operating the Rock Saw.
- Do not attempt to move the saw sideways while it is in the ground.



TRANSPORTING THE ROCK SAW

- Travel only with the attachment in a safe transport position to prevent uncontrolled movement. Drive slowly over rough ground and on slopes.
- When driving on public roads use safety lights, reflectors, Slow Moving Vehicle signs etc., to prevent accidents. Check local government regulations that may affect you.
- Do not drive close to ditches, excavations, etc., cave in could result.
- Do not smoke when refueling the prime mover. Allow room in the gas tank for expansion. Wipe up any spilled fuel. Secure cap tightly when done.



MAINTAINING THE ROCK SAW

- Before performing maintenance, lower the attachment to the ground, turn off the engine, remove the key and apply the brakes.
- Never perform any work on the attachment unless you are authorized and qualified to do so. Always read the operator service manual's before any repair is made. After completing maintenance or repair, check for correct functioning of the attachment. If not functioning properly, always tag "DO NOT OPERATE" until all problems are corrected.
- Worn, damaged, or illegible safety decals must be replaced. New safety decals can be ordered from BRADCO.
- Never make hydraulic repairs while the system is under pressure. Serious personal injury or death could result.
- Never work under a raised attachment.

DECALS

DECAL PLACEMENT

GENERAL INFORMATION

The diagrams on this page show the location of the decals used on the BRADCO Rock Saws. The decals are identified by their part numbers, with reductions of the actual decals located on the following pages. Use this information to order replacements for lost or damaged decals. Be sure to read all decals before operating the attachment. They contain information you need to know for both safety and longevity.

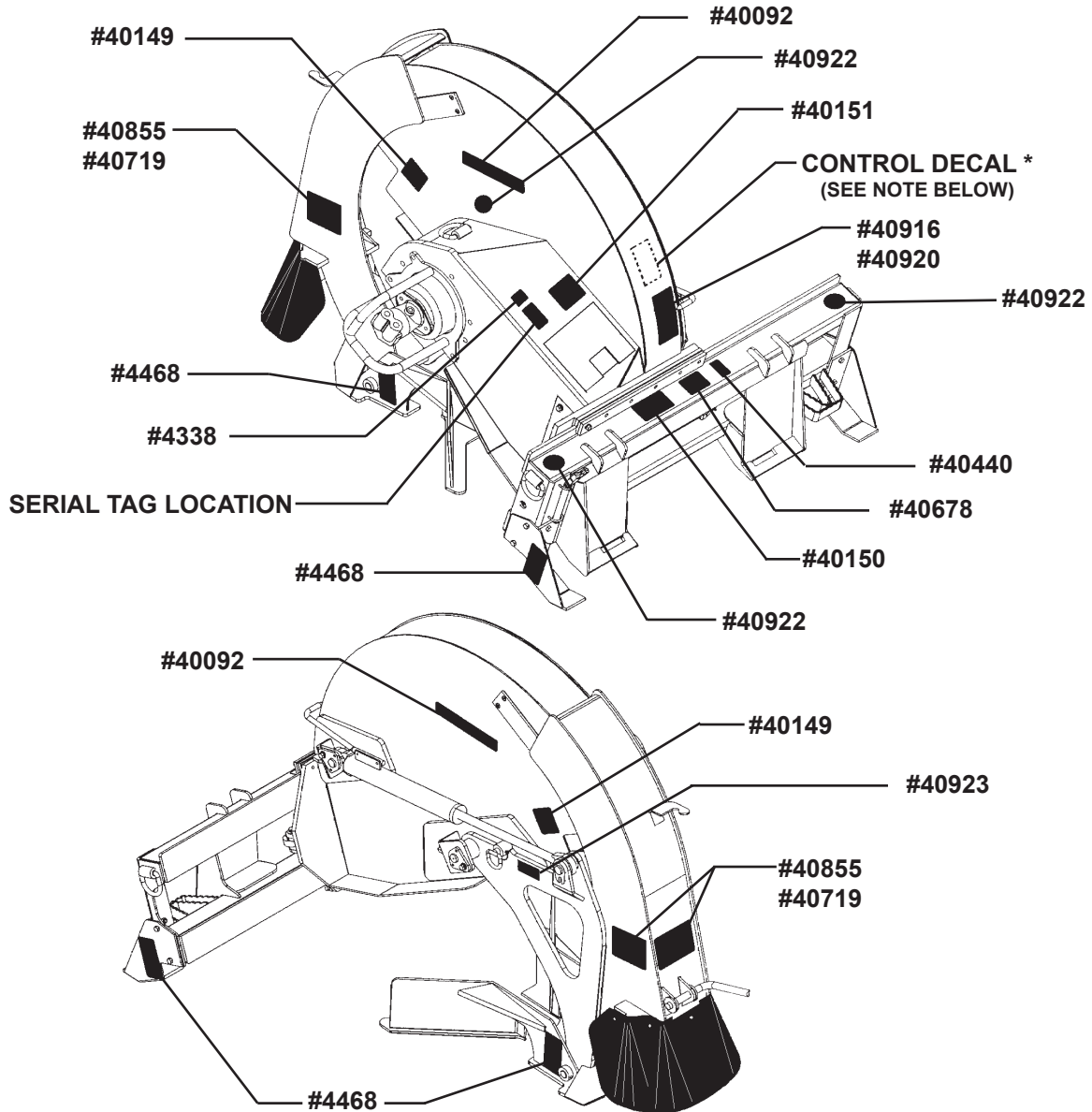

*** NOTE: ATTACHMENT CONTROL DECALS ARE PURCHASED ACCORDING TO THE MULTI-FUNCTION ELECTRIC CONTROL HANDLE YOUR UNIT IS EQUIPPED WITH. NOT REQUIRED WHEN USED WITH BRADCO CONTROL BOX.**

IMPORTANT: Keep all safety signs clean and legible. Replace all missing, illegible, or damaged safety signs. When replacing parts with safety signs attached, the safety signs must also be replaced.

REPLACING SAFETY SIGNS: Clean the area of application with nonflammable solvent, then wash the same area with soap and water. Allow the surface to fully dry. Remove the backing from the safety sign, exposing the

10495 5-10-06

DECALS

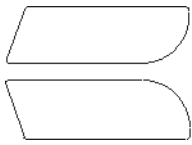

BRADCO

BRADCO LOGO
PART #40092

⚠ WARNING

BEFORE LEAVING OPERATOR'S SEAT:

1. Lower lift arms against frame and place unit on the ground.
2. Disengage auxiliary hydraulics.
3. Stop Engine and Remove Key.
4. Engage Parking Brake. #40678

WARNING! BEFORE LEAVING SEAT
PART #40678

DEPTH

PARK

6"

12"

18"

24"

#40916

DEPTH CONTROL
PART #40920 (18" ROCK SAW)
PART #40916 (24" ROCK SAW)



MADE IN U.S.A.
PART #4338



LIFT HOOK
PART #40922

ATTACHMENT CONTROLS

LIFT

SIDE SHIFT

40XT - 70XT
"A" Pillar Controls

75XT - 95XT
Right Console Controls

#40934

*ATTACHMENT CONTROLS
CASE STYLE
PART #40934

SIDE SHIFT
LEFT / RIGHT
LIFT
UP / DOWN

ATTACHMENT CONTROLS

#40933

*ATTACHMENT CONTROLS
NEW HOLLAND & CASE
STYLE
PART #40933

LOCKING PIN

→

←

PARK / TRANSPORT
OPERATION

#40923

LOCKING PIN OPERATION
PART #40923

***NOTE: ATTACHMENT CONTROL DECALS ARE PURCHASED ACCORDING TO THE MULTI-FUNCTION ELECTRIC CONTROL HANDLE YOUR UNIT IS EQUIPPED WITH. NONE REQUIRED WITH THE BRADCO CONTROL BOX.**

DECALS



WARNING! HIGH PRESSURE FLUID
PART #40151



DANGER! PINCH POINT
PART #40149



DANGER! FLYING DEBRIS
PART #40719 (7.38" X 5")
PART #40855 (6" X 4.18")



WARNING! FOOT CRUSH
PART #4468

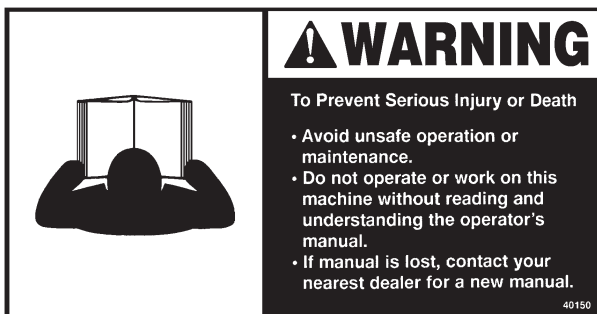

WARNING! READ MANUAL
PART #40150



CALL BEFORE YOU DIG
PART #40440

INSTALLATION

GENERAL INFORMATION

The following instructions will help you to mount your rock saw onto your skid-steer loader. The rock saw uses the quick-attach system for ease of installation. Therefore, if you know how to attach your loader bucket, attaching the rock saw should prove no problem.

Remember to read all safety warnings, decals and operating instructions before operating the attachment. If there is any portion of this manual that you do not understand, contact your dealer.

WARNING! THE 18" AND 24" ROCK SAWS ARE DESIGNED FOR USE ON HIGH FLOW HYDRAULIC SYSTEMS.



DO NOT ATTACH OR OPERATE ANY ATTACHMENT THAT EXCEEDS THE RECOMMENDED LIFTING CAPACITY OF YOUR SKID-STEER.

INSTALLATION INSTRUCTIONS

1. Remove the shipping banding from around the rock saw and skid.
2. Remove any attachments from the front of the loader.
3. Following all standard safety practices and the instructions for installing an attachment in your skid-steer operator's manual, install the rock saw onto your skid-steer.

NOTE: It is important to make sure the locking mechanism on your quick attach is engaged, therefore locking the attachment onto the skid-steer.

4. Lower the unit to the ground and remove the key.
5. Relieve any pressure from the auxiliary hydraulic system and after making sure that there is not any foreign matter on the hydraulic couplers, connect the case drain coupler to the case drain on your skid-steer loader.
6. Connect the power and return couplers to the high flow auxiliary hydraulic system of your skid-steer loader. Hose tie the hoses together and route the hoses in such a fashion as to avoid pinching or chafing.

CAUTION! BE SURE CASE DRAIN COUPLER IS COMPLETELY ENGAGED. IMMEDIATE HYDRAULIC MOTOR SEAL FAILURE AND PLANETARY DAMAGE WILL OCCUR IF CASE DRAIN IS NOT SUCCESSFULLY CONNECTED.



7. Connect the electrical wire harness from the rock saw to the auxiliary electrical connector on the front of the skid-steer (if so equipped). If your skid-steer is not equipped with an electrical connector and you are using the BRADCO control handle, connect the wiring harness to the control handle and place the control handle inside of the skid-steer operator's station.

WARNING! Do not operate the rock saw from outside of the skid-steer operator's station.



INSTALLATION

8. Following all standard safety practices, start the skid-steer and run all cylinders through their full cycle to purge any air from the system. Check that all controls function in accordance with BRADCO control box or with the operating decal (if so equipped).

Your rock saw is now installed and ready for operation.

DISCONNECT INSTRUCTIONS

1. Center the rock saw on the side shift frame.
2. Adjust depth setting to "PARK" and engage the locking pin on the right side of the rock saw.
3. Set attachment on a firm level surface.
4. Following Safety Shut Down Procedures; stop the engine and set the parking brake. Relieve any pressure in the hydraulic lines.
5. Disconnect the power and return hoses from the auxiliary hydraulics and then disconnect the case drain hose.
6. Disconnect the electrical wire harness from the auxiliary electrical connector or the BRADCO control handle.
7. Following all standard safety practices and the instructions for disconnecting an attachment in your skid-steer operator's manual, disconnect the rock saw from your skid-steer allowing the attachment to lower onto the stands as the skid-steer is disengaged.
8. Connect the hydraulic couplers on the attachment together to prevent contaminants from entering the hydraulic system.

OPERATING INSTRUCTIONS

GENERAL INFORMATION

The BRADCO rock saw attaches to the toolbar/quick-attach mechanism of your skid-steer loader. Due to this arrangement, thorough knowledge of the skid-steer controls is necessary for machine operation. Read and understand your skid-steer operator's manual for information regarding skid-steer operation before attempting to use the attachment.

Check the operating surface. The standard all purpose picks can be used to saw both asphalt and concrete. There are optional concrete picks that are recommended if the rock saw is to be used extensively for concrete. These picks do not perform as well when sawing through asphalt, especially in warmer weather.

Review the job at hand and determine the required depth and the side shift position of the rock saw. Best performance is obtained when the rock saw is in the center position. Side shift should be used when visibility is a determining factor such as sawing next to an obstacle such as a building.

NOTICE: The wheel/planetary nuts (#10003) must be torqued to 220-260 ft. lbs after the first four hours of operation and every 40 hours thereafter.

ROCK SAW OPERATION

WARNING! CHECK THE WORK AREA AND KNOW WHERE ALL UTILITY LINES ARE BEFORE OPERATING THE ROCK SAW.



OPERATE THE ROCK SAW FROM INSIDE THE OPERATOR'S STATION OF YOUR SKID-STEER LOADER ONLY.

1. Clear area of all bystanders.

NOTE: There is a control valve on the rock saw that can be manually set to change the speed of the lift cylinder. Before operation, place the locking pin in the operation position and run the lift cylinder through a complete cycle noting the speed. For maximum production it is recommended that the harder the material the slower the cylinder speed.

2. Determine the desired depth and shift the cutting wheel to the required side shift location. Position the rock saw at the starting point of the cut. Place the locking pin in the operation position.
3. With the skid shoe in the PARK position, place the skid shoe on the ground and roll out the loader bucket cylinder until the front tires of the skid steer are off the ground
4. With the cutting wheel off the ground, start wheel rotation. (Picks at the bottom of the wheel must be moving in the same forward direction that the rock saw travels. If they are not, change the power and return hoses at the motor end.)

OPERATING INSTRUCTIONS

5. Increase engine to full RPM. Start the sawing operation by retracting the skid shoe with the lift cylinder. This must be done slowly to avoid stalling the machine. If the rock saw stalls you are retracting the skid shoe faster than the saw is cutting. Lower the skid shoe (which will lift the cutting wheel) until the wheel restarts.
6. Retract the skid shoe until the desired depth is achieved. If the rock saw continues to stall, shut down and reset the control valve to slow down cylinder speed.

NOTE: When the skid shoe begins to come off the ground and the front tires of the skid steer have reached the ground, stop retracting the lift cylinder and roll the loader bucket cylinder out to get the front tires back off the ground.

7. Advance forward. If the rock saw stalls, you are traveling faster than the saw is cutting. Back out of the cut until the wheel restarts and then advance slowly.

NOTE: Do NOT side shift the rock saw while the wheel is in the cut. The cutting wheel will not cut in a side to side direction.

OPERATING TIPS

- For optimal cutting and reduced vibration, operate the rock saw with the rear tires of the loader and the rock saw rollers on the ground and enough down pressure on the skid shoe to prevent the saw from plunging into the ground and stalling. **NOTE: This is not possible with some skid steer applications.**
- If the rock saw is stalling out you are either traveling too fast or retracting the skid shoe faster than the saw is cutting. Back out of the cut or lower the skid shoe until the wheel restarts.
- When the skid shoe begins to come off the ground and the front tires of the skid steer have reached the ground, stop retracting the lift cylinder and roll the loader bucket cylinder out to lift the front tires back off the ground.

ENDING THE CUT

1. To end the cutting operation, stop all forward movement and raise the cutting wheel out of the cut by lowering the skid shoe to the PARK position.
2. Idle the loader engine and turn the rock saw off. **DO NOT TRANSPORT THE ROCK SAW WHILE THE CUTTING WHEEL IS IN MOTION.**
3. Move the unit away from the cut.
4. Lower the attachment to the ground and turn off the loader engine.
5. Apply the brakes and remove the key before leaving the operator's station.
6. Install the locking pin in the PARK/TRANSPORT position.

OPERATING INSTRUCTIONS

NOTICE: Periodic observation must be made of the transmission oil temperature indicator when sawing with the high flow hydraulic systems. Depending on the ambient temperature and the duty cycle of the machine hydraulic oil may overheat. If indicator comes on, shut off the rock saw and allow the skid steer to idle until the temperature falls below 160° Fahrenheit. If the system continues running hot it may be necessary to clean any debris from the oil cooler and radiator. Check engine air filter and also the hydraulic oil level. Continuous or excessive overheating may cause machine damage.

PREPARATION FOR STORAGE

1. Clean exterior thoroughly removing all mud, dirt and grease.
2. Inspect for visible signs of wear. Order any parts required.
3. Coat all exposed cylinder rods with grease.
4. Check for missing or worn picks. Replace as required.
5. Tighten all loose nuts and capscrews.
6. Grease all grease fittings.
7. Connect coupler together to protect hydraulic system from contamination. (Cap any couplers or fittings not protected.)
8. Replace decals if damaged or in unreadable condition.
9. Store unit in a dry and protected place. Leaving outside will materially shorten its life.

REMOVING FROM STORAGE

1. Remove all protective coverings.
2. Check hydraulic hoses for deterioration and replace if necessary.

TRANSPORTING

1. Check that the Locking Pin is in the Transport position.
2. Follow all federal, state and local regulations when transporting on public roads.
3. Use extra care when loading and unloading the machine onto a truck or trailer.
4. Follow all transporting instructions listed in the Safety Precautions section of this manual.

MAINTENANCE AND SERVICE

GENERAL INFORMATION

Regular maintenance is the key to long equipment life and safe operation. Maintenance requirements have been reduced to an absolute minimum. However it is very important that these maintenance functions be performed as described below.

WARNING! Never do any maintenance to the rock saw while it is running. Exercise the **MANDATORY SAFETY SHUTDOWN PROCEDURE BEFORE** working on or around the rock saw.



AFTER FIRST 4 HOURS (BREAK IN PERIOD)

- Torque the wheel/planetary nuts (#10003) to 220-260 ft. lbs.

DAILY

- Check to be sure case drain coupler is completely engaged.
- Check skid-steer hydraulic system to ensure an adequate level of hydraulic oil.
- Check all hardware and tighten if necessary. See Bolt Torque Specifications Section.
- Check hydraulic system for hydraulic leaks.
- Check for missing or illegible Safety / Warning Decals.
- Check picks for freedom of rotation, flat spots and wear. Replace worn or missing picks or any picks that are not rotating freely or have flat spots.
- Visually inspect the machine for worn parts or cracked welds and repair as necessary.
- Lubricate grease fittings on the lift arm pivot pin and the pivot pins on the left and right stand.

EVERY 40 HOURS

- Lubricate grease fittings on cylinder ends.
- Torque the wheel/planetary nuts (#10003) to 220-260 ft. lbs.

EVERY 2500 HOURS OR 12 MONTHS

- Change gear oil (Castrol SP320) in planetary. See Maintenance and Service Section for details

WARNING! Escaping fluid under pressure can have sufficient force to penetrate the skin causing serious personal injury. Fluid escaping from a very small hole can be almost invisible. Use a piece of cardboard or wood, rather than hands to search for suspected leaks.



Keep unprotected body parts, such as face, eyes, and arms as far away as possible from a suspected leak. Flesh injected with hydraulic fluid may develop gangrene or other permanent disabilities.

If injured by injected fluid, see a doctor at once. If your doctor is not familiar with this type of injury, ask him to research it immediately to determine proper treatment.

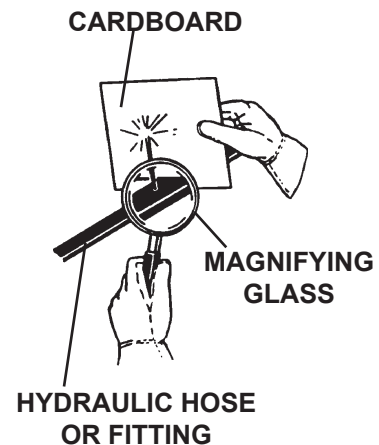

10549 5-11-06

MAINTENANCE AND SERVICE

IMPORTANT: When replacing parts use only factory approved replacement parts. Manufacturer will not claim responsibility for use of unapproved parts or accessories and/or other damages as a result of their use.

PICK REPLACEMENT

Picks should be replaced if you are changing to a different application pick, they are broken, worn, flat spot or are seized in the pick holder and do not rotate freely.

WARNING! Always wear safety glasses with side shields when striking metal. Failure to heed could result in serious injury to the eyes or other parts of the body. **DO NOT** attempt to check the picks with the rock saw in a raised and unsupported position.



1. Raise the skid shoe / lift arm by retracting the lift cylinder and installing the locking pin to prevent the lift arm from accidentally lowering.
2. Support the rock saw by attaching a lift hook on the left side of the mainframe in the “D” ring provided.
3. Hold the extracting tool (pick puller) in one hand and place the jaws in the groove of the pick, with the offset handle pointing away from the pick holder.
4. Using a lead hammer or rubber-headed mallet, hit the raised pad on the tool until the pick starts to move. Continue tapping until the pick is removed.
5. Insert the new pick into the jaws of the extracting tool (pick puller) so that the raised pad of the tool is pointing in the same direction as the pick point.
6. Position the new pick in the pick holder on the drum and with a lead hammer or rubber-headed mallet, hit the raised pad of the tool to start the pick into the pick holder. (Clean out any foreign material from the pick holder before installing the new pick.)
7. Once the pick is started into the pick holder strike the tool pad one strong blow to pop the pick into the holder.

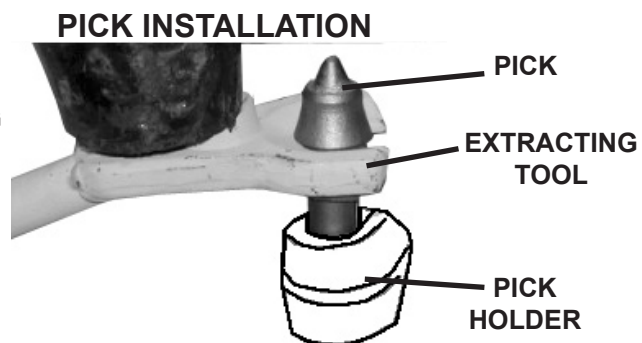
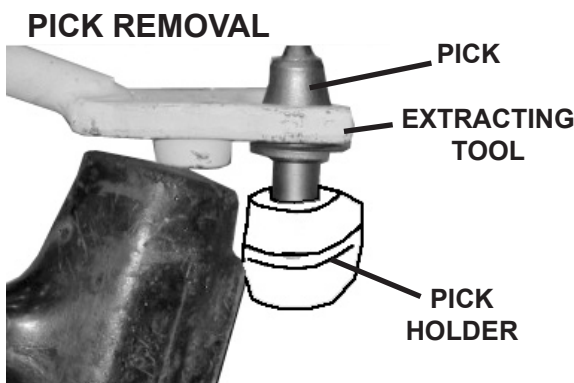

NOTE: The pick is properly seated when its shoulder is against the face of the pick holder. Check to be sure the pick rotates freely.

MAINTENANCE AND SERVICE

- When all accessible picks have been changed, clear the area of bystanders and start the loader. Slowly rotate the cutting wheel approximately 1/4 turn to access more picks.
- Repeat Steps #3 through #8 until all picks have been replaced.

PICK AND HOLDER REPLACEMENT.

It will be necessary to change the complete bolt-on pick holder if the holder is damaged or when changing the width of cut.

- Raise the skid shoe / lift arm by retracting the lift cylinder and installing the locking pin to prevent the lift arm from accidentally lowering.
- Support the rock saw by attaching a lift hook on the left side of the mainframe in the "D" ring provided.
- Replace the desired pick holders with new hardware. Torque to specification. (See Bolt Torque Specification Section.)

NOTE: You must have all 2.5" cut holders or all 4.00" cut holders to maintain the balance on the cutting wheel. Different size holders will cause the rock saw to vibrate and bounce and greatly reduce the performance. The pick holders must all be mounted on the same side of the cutting wheel as the planetary with the mounting bolts going into the countersunk hole on the wheel and the lock nuts on the outside of the holder.

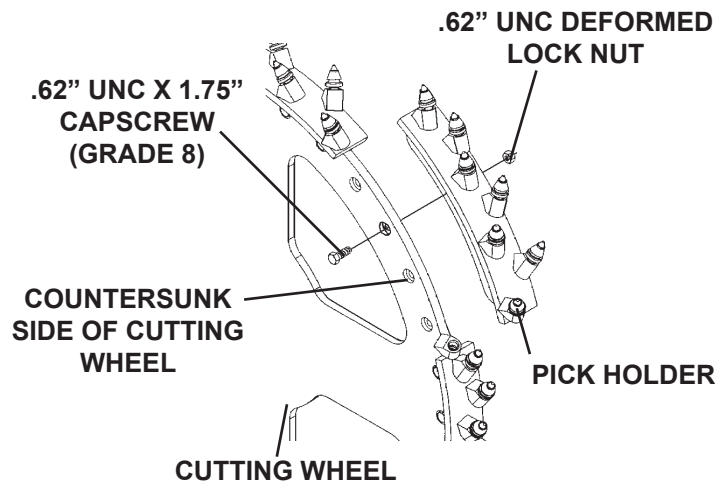

HYDRAULIC MOTOR REPLACEMENT OR REPAIR

IMPORTANT: Replacing INTERNAL motor seals or disassembly of the motor will void warranty.

NOTICE: Damage to the motor shaft seal may be caused by excessive case drain pressure due to unconnected or malfunctioning drain line.

- Tag and disconnect the power and return hoses along with the case drain hose from the hydraulic motor. Cap or plug hose ends and motor ports to prevent contaminants from entering the hydraulic system.
- Remove the capscrews securing the motor to the planetary.

10551 5-11-06

MAINTENANCE AND SERVICE

3. Clean all mating surfaces of the planetary to prepare it for the new motor. NOTE: If not bolting new motor on immediately, cover planetary to prevent contaminants from entering the hydraulic system.

NOTE: If replacing shaft seals: Replace seals and gasket and continue with Step #4 to reinstall existing motor.

4. Replace the motor gasket #102594 between the motor and the planetary.
5. Bolt the new or repaired motor onto the planetary using the existing hardware. (Check to make sure the motor is in the correct position with the ports turned up.) Torque to specification. (See Bolt Torque Specification Section.)
6. Reconnect the hydraulic hoses and fittings to the motor.
9. Refill planetary with Gear Oil (Castrol SP 320) through the fill plug located on the top of the planetary.
10. Check for leaks and tighten as required.

PLANETARY REPLACEMENT OR REPAIR

A hoist with at least a 3000 lb. capacity is required when removing the planetary or shaft seal.

NOTE: Leaking planetary shaft seal can be caused by a damaged motor seal leaking oil into the planetary. Check motor seal first if planetary is leaking. If motor seal is damaged go to “HYDRAULIC MOTOR REPLACEMENT OR REPAIR” and change motor seal.

IMPORTANT: Replacing internal motor seals or disassembly of the planetary will void warranty.

1. Disconnect the rock saw from the skid steer loader by following the “Disconnect Instructions” in the Installation section of this manual.
2. Attach the hoist to both lift hook locations on the left side of the rock saw (mainframe and side shift frame).
3. Slowly and very carefully lift the rock saw and remove the rod end lift cylinder pin and locking pin. Lay the rock saw on its side with the planetary up and manually position the lift arm and skid shoe in the up position. (Blocking up the front of the attachment to keep it fairly level is recommended but not required.)
4. Tag and disconnect the power and return hoses along with the case drain hose from the hydraulic motor. Cap or plug hose ends and motor ports to prevent contaminants from entering the hydraulic system.
5. Remove the motor guard.

MAINTENANCE AND SERVICE

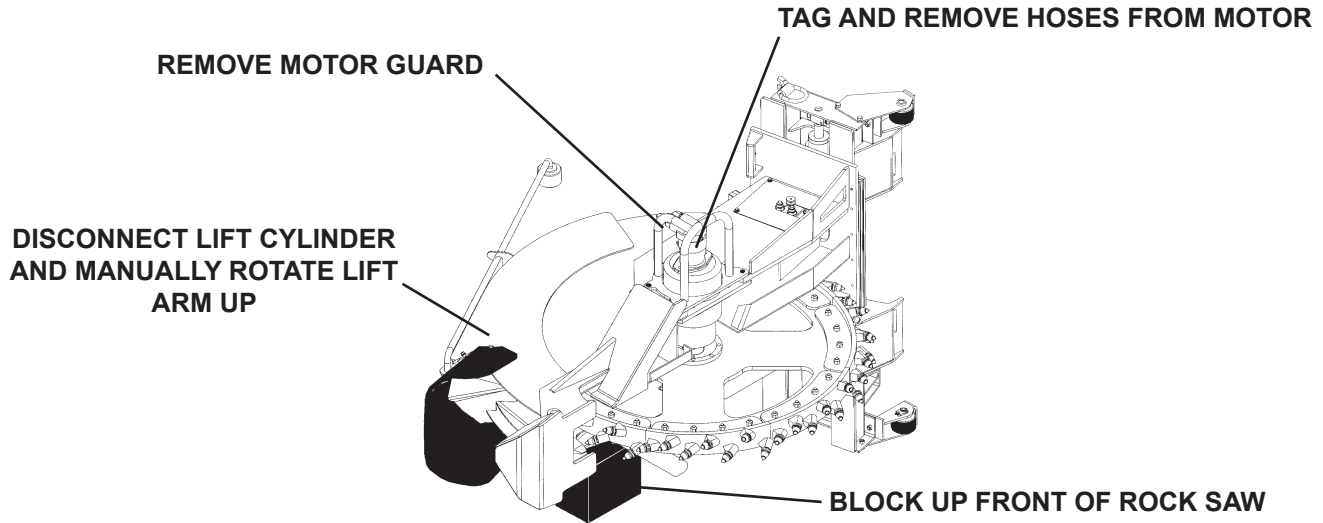

NOTE: The planetary and wheel assembly will need to be supported for removal. It is recommended that you have two .62" UNC eyebolts for this purpose.

6. Remove two of the .62" X 2.50" bolts securing the planetary to the planetary mounting plate and install two .62" UNC eyebolts. Attach hoist to eyebolts to support wheel assembly for removal.

CAUTION! Be sure the wheel and planetary assembly is securely supported before removal of the bolts in step #7. Failure to properly support the assembly will allow the wheel to drop and may cause machine damage or injury.

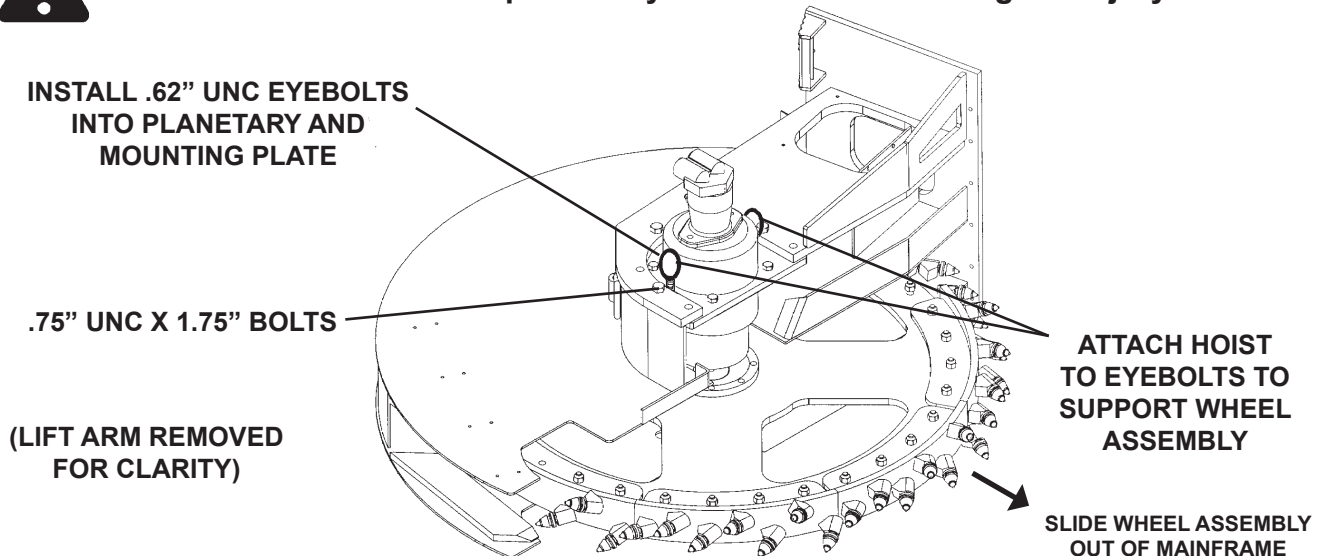

7. Remove the four .75" UNC X 1.75" bolts securing the planetary mounting plate to the mainframe. (This will free the wheel assembly from the mainframe. Be sure the assembly is sufficiently supported.)
8. Using the hoist to support the wheel and planetary assembly, slide it out of the mainframe.

10553 5-11-06

MAINTENANCE AND SERVICE

9. Support the cutting wheel securely off the ground and remove the eight .62" lock nuts securing the planetary to the cutting wheel. NOTE: Make sure the cutting wheel is properly supported. When the lock nuts are removed the cutting wheel is no longer supported with the eyebolts.
10. Install the new planetary to the cutting wheel using the existing hardware.
11. Remove the eyebolts and the remaining .62" bolts securing the planetary to the mounting plate. Remove the mounting plate.

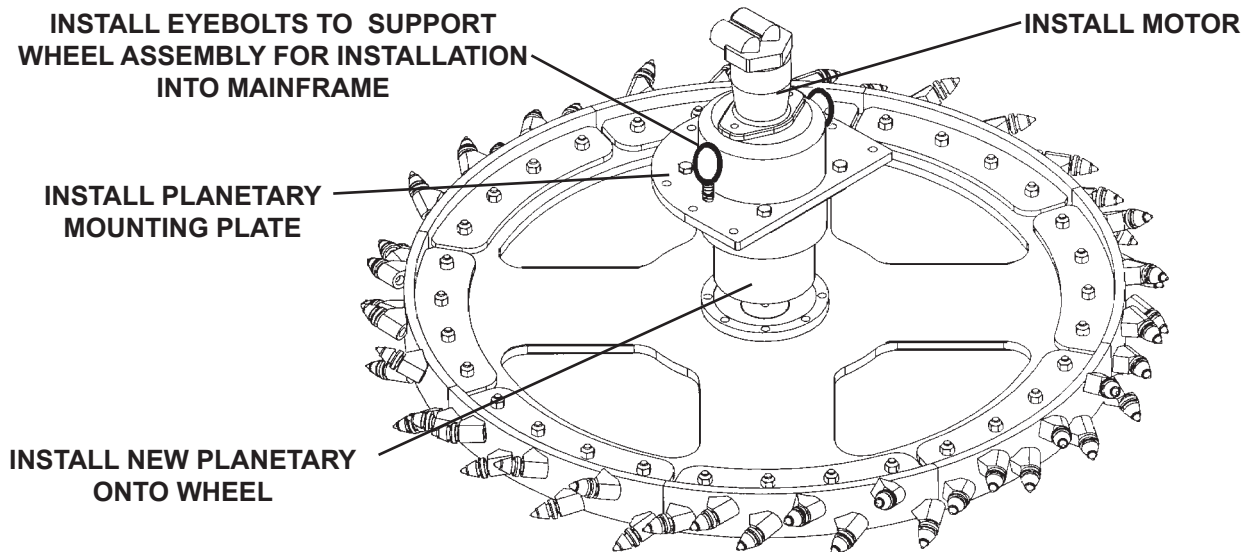

12. Install the mounting plate onto the new planetary using the existing hardware and the two eyebolts for installing into the mainframe.
13. Remove the capscrews securing the motor to the old planetary.
14. Clean the mating surface of the motor to prepare it for the installation onto the new planetary.

NOTE: If replacing shaft seals: Replace seals and continue with Step #12 to reinstall existing components. NOTE: Leaking planetary shaft seal can be caused by a damaged motor seal leaking oil into the planetary. Check motor seal first if planetary is leaking.

15. Install a new motor gasket #102594 between the motor and the new planetary. Bolt the motor onto the new planetary using the existing hardware. (Check to make sure the motor is in the correct position with the ports turned up.) Torque to specification.

NOTE: It is recommended that all picks be inspected and replaced if necessary and that the pick holder hardware be checked and tightened while the wheel is removed.

16. Connect the hoist to the eyebolts and reinstall the wheel and planetary assembly into the mainframe. Secure to the mainframe by installing the existing .75" hardware. Be sure to use the three 2.00" long bolts for reinstalling the motor guard.

MAINTENANCE AND SERVICE

17. Remove the eyebolts and install the last two .62" bolts.
18. Reconnect the hydraulic hoses and fittings to the motor.
19. Clear the area of any bystanders and slowly lift the rock saw (using the hoist) to an upright position. Position the lift cylinder and install the rod end cylinder pin and locking pin in the "Park" position.
20. Remove lift hooks and attach rock saw to your skid steer by following the "Installation Instructions" in the installation section of this manual.
21. Check for leaks and tighten as required.

CHANGING PLANETARY OIL

NOTICE: Disassembly of the planetary will void warranty.

The planetary is a sealed unit. If there is any sign of oil leaks please contact your nearest BRADCO dealer before carrying out any repairs. There can be other causes for seal leaks. The planetary uses the Gear Oil (Castrol SP 320 for lubrication of gears and bearings. The unit holds approximately 2 quarts of gear oil. There is a drain plug located on the underneath side of the planetary and a fill plug located on the top. NOTE: When filling be sure all air is out of the planetary.

The planetary oil should be drained and replaced after the first 8 months of use and every 12 months or 2500 hours thereafter, whichever ever comes first.

MAINTENANCE AND SERVICE

CYLINDER SEAL REPLACEMENT

The following information is provided to assist you in the event you should need to repair or rebuild a hydraulic cylinder. When working on hydraulic cylinders, make sure that the work area and tools are clean and free of dirt to prevent contamination of the hydraulic system and damage to the hydraulic cylinders. Always protect the active part of the cylinder rod (the chrome section). Nicks or scratches on the surface of the rod could result in cylinder failure. Clean all parts thoroughly with a cleaning solvent before reassembly.

DISASSEMBLY PROCEDURE

IMPORTANT: Do not contact the active surface of the cylinder rod with the vise. Damage to the rod could result.

THREADED TYPE GLAND

1. Rotate the gland with a spanner wrench counterclockwise until the gland is free of the cylinder tube.
2. Pull the cylinder rod from the cylinder tube and inspect the piston and the bore of the cylinder tube for deep scratches or galling. If damaged, the piston AND the cylinder tube must be replaced.

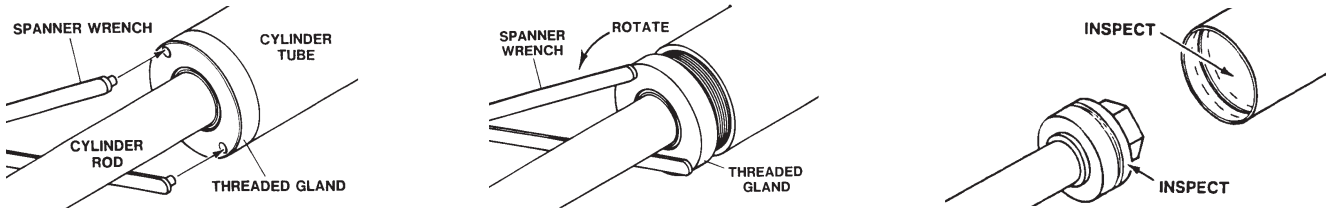

3. Remove the hex nut, piston, flat washer or spacer tube (if so equipped), and gland from the cylinder rod. If the cylinder rod is rusty, scratched, or bent, it must be replaced.
4. Remove and discard all the old seals.



ASSEMBLY PROCEDURE

IMPORTANT: Replace all seals even if they do not appear to be damaged. Failure to replace all seals may result in premature cylinder failure. **NOTE:** Seal kits will service most cylinders of similar bore size and rod diameter.

1. Install the cylinder rod seal in the gland first. Be careful not to damage the seal in the process, as it is somewhat difficult to install.

NOTE: A special installation tool (Part #65349) is available to help with installing the seal. Simply fit the end of the tool over the seal so that the large prong of the tool is on the outside of the seal, and the two smaller prongs on the inside. The lip of the seal should be facing towards the tool. Rotate the handles on the tool around to wrap the seal around the end of the tool.

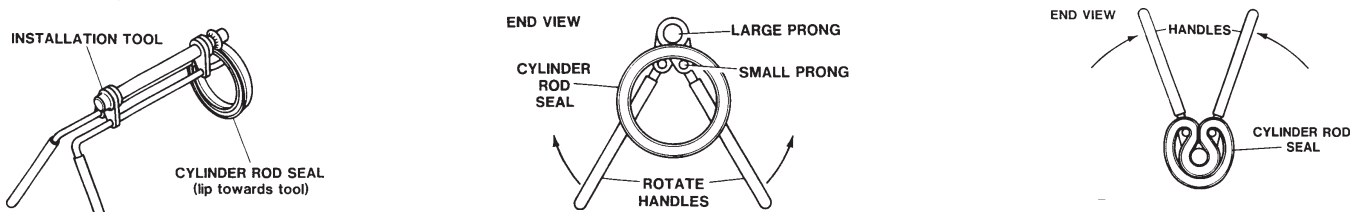

10356 10-13-05

MAINTENANCE AND SERVICE

Now insert the seal into the gland from the inner end. Position the seal in its groove, and release and remove the tool. Press the seal into its seat the rest of the way by hand.

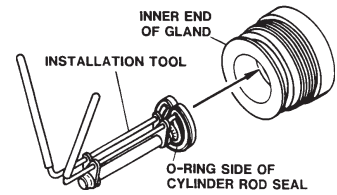

- Install the new piston ring, rod wiper, O-rings and backup washers, if applicable, on the piston.

Be careful not to damage the seals. Caution must be used when installing the piston ring. The ring must be stretched carefully over the piston with a smooth, round, pointed tool.

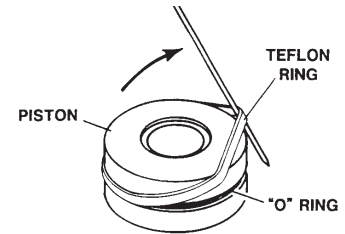

- After installing the rod seal inside the gland, as shown in step #1, install the external seal.

NOTE: Threaded glands may have been equipped with a separate O-ring and backup washer system or a polypak (all in one) type seal. Current seal kits contain a polypak (all in one) type seal to replace the discarded seal types on ALL THREADED GLANDS.

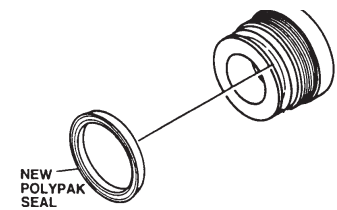

- Slide the gland onto the cylinder rod, being careful not to damage the rod wiper. Then install the spacer, or flat washer (if so equipped), small o-ring, piston, and hex nut onto the end of the cylinder rod.
- Secure the cylinder rod (mounting end) in a vise with a support at its center. Torque the nut to the amount shown for the thread diameter of the cylinder rod (see chart).

Thread Diameter	POUNDS - FEET
7/8"	150-200
*1"	230-325
1-1/8"	350-480
1-1/4"	490-670
1-3/8"	670-900
* 1" Thread Diameter WITH 1.25" Rod Diameter Min. 230 ft. lbs. Max. 250 ft. lbs.	

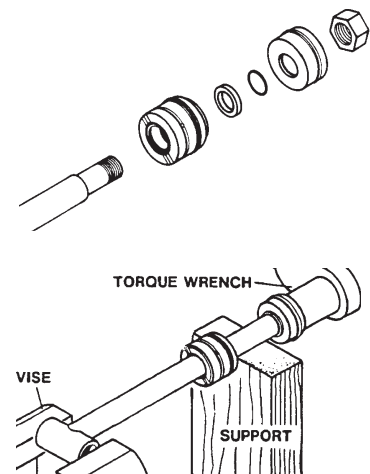

IMPORTANT: Do not contact the active surface of the cylinder rod with the vise. Damage to the rod could result.

- Apply a lubricant (such as Lubriplate #105) to the piston and teflon ring. Insert the cylinder rod assembly into the cylinder tube.

IMPORTANT: Ensure that the piston ring fits squarely into the cylinder tube and piston groove, otherwise the ring may be damaged and a leak will occur.

- Use a spanner wrench to rotate the gland clockwise into the cylinder. Continue to rotate the gland with the spanner wrench until it is tight.

WARNING! Cylinders serviced in the field are to be tested for leakage prior to the attachment being placed in work. Failure to test rebuilt cylinders could result in damage to the cylinder and/or the attachment, cause severe personal injury or even death.



TROUBLESHOOTING

<u>PROBLEM</u>	<u>POSSIBLE CAUSE</u>	<u>POSSIBLE REMEDY</u>
Motor on the rock saw will not operate.	Auxiliary hoses not hooked up to the skid-steer.	Engage Couplers
	Obstruction in hydraulic lines.	Remove obstruction and replace if necessary.
	Hydraulic motor damaged or seals blown.	Call Bradco service department for instructions.
	Skid-steer auxiliary valve not engaged.	Engage auxiliary valve.
	Rocks and debris caught between wheel and mainframe.	Remove debris
Wheel rotates sluggishly.	Insufficient hydraulic flow from the skid-steer.	Refer to skid-steer's owners manual.
	Damaged quick coupler.	Replace if necessary.
	Hydraulic motor damaged or seals blown.	Call Bradco service department for instructions.
	Oil filter on skid-steer is dirty.	Refer to skid-steer's owners manual.
Leaking Oil.	Loose or damaged hydraulic line.	Tighten or replace.
	O-Rings on fittings damaged.	Replace if necessary.
	Hydraulic motor damaged or seals blown.	Call Bradco service department for instructions.
	Fittings loose or damaged.	Tighten or replace.
	Cylinder seals damaged.	Replace cylinder seals.
Insufficient power.	Insufficient hydraulic flow from the skid-steer.	Refer to skid-steer's owners manual.
	Relief valve setting adjusted too low.	Refer to skid-steer's owners manual.
	Hydraulic motor damaged or seals blown.	Call Bradco service department for instructions.
	Oil filter on skid-steer is dirty.	Refer to skid-steer's owners manual.
Wheel rotates in the wrong direction.	Hoses from the valve to the motor incorrectly connected.	Switch hoses at the motor end.
Excessive vibration during operation.	Picks are worn or broken.	Inspect and replace as necessary.
	Picks contain flat spots or are not rotating freely.	Inspect and replace as necessary.
	Two different size cutting pick holders.	Verify wheel contains all 2.5" cutting width holders or 4.0" cutting width holders.
	Insufficient down force due to incorrect operating procedure.	Refer to the Operating section of this manual.

10562 3-20-06

TROUBLESHOOTING

<u>PROBLEM</u>	<u>POSSIBLE CAUSE</u>	<u>POSSIBLE REMEDY</u>
Excessive oil temperature.	Hydraulic oil level too low.	Refer to skid-steer's owners manual
	Obstruction in hydraulic lines.	Remove obstruction and replace if necessary.
	Hydraulic oil or oil filter in skid-steer is dirty.	Refer to skid-steer's owners manual.
	Relief valve setting adjusted too low.	Refer to skid-steer's owners manual.
	Couplers not engaged.	Engage couplers.
A Hydraulic cylinder not operating.	Insufficient hydraulic flow from the skid-steer.	Refer to skid-steer's owners manual.
	Cylinder rod bent.	Visually inspect the cylinder for damage.
	Cylinder seals damaged.	Replace cylinder seals.
	Obstruction in hydraulic lines.	Remove obstruction and replace if necessary.
Hydraulic cylinders not functioning.	Blown fuse on skid-steer.	Refer to skid-steer's owners manual.
	Damaged electrical wiring.	Test and replace if necessary.
	Faulty switch or electrical connection.	Repair or replace as necessary.
	Solenoid valve spool bent.	Replace spool.
	Faulty control valve coil.	Replace coil.
Hydraulic cylinders only operating in one direction.	Contaminants in the hydraulic system and solenoid valve.	Remove spool from solenoid valve and check for foreign material. Clean or replace. Remove spool from solenoid valve and check seals for damage. Replace if necessary.
	Damaged electrical wiring.	Test and replace if necessary.
	Solenoid valve spool bent.	Replace spool.
	Faulty control valve coil	Replace coil.



BOLT TORQUE

BOLT TORQUE SPECIFICATIONS

GENERAL TORQUE SPECIFICATION TABLE

Use the following torques when special torques are not given. These values apply to fasteners as received from suppliers, dry, or when lubricated with normal engine oil. They do not apply if special graphited or moly disulphide greases or other extreme pressure lubricants are used. This applies to both UNF and UNC threads. Remember to always use grade five or better when replacing bolts.

IMPORTANT: On all PLATED GRADE 8 bolts, reduce torque 15% from listed bolt torque specification.

SAE Grade No.		2				5				8*			
Bolt head identification marks as per grade. NOTE: Manufacturing Marks Will Vary													
		TORQUE		TORQUE		TORQUE		TORQUE		TORQUE		TORQUE	
Bolt Size		Pounds Feet		Newton-Meters		Pounds Feet		Newton-Meters		Pounds Feet		Newton-Meters	
Inches	Millimeters	Min.	Max.	Min.	Max.	Min.	Max.	Min.	Max.	Min.	Max.	Min.	Max.
1/4	6.35	5	6	7	8	9	11	12	15	12	15	16	20
5/16	7.94	10	12	14	16	17	20.5	23	28	24	29	33	39
3/8	9.53	20	23	27	31	35	42	48	57	45	54	61	73
7/16	11.11	30	35	41	47	54	64	73	87	70	84	95	114
1/2	12.70	45	52	61	70	80	96	109	130	110	132	149	179
9/16	14.29	65	75	88	102	110	132	149	179	160	192	217	260
5/8	15.88	95	105	129	142	150	180	203	244	220	264	298	358
3/4	19.05	150	185	203	251	270	324	366	439	380	456	515	618
7/8	22.23	160	200	217	271	400	480	542	651	600	720	814	976
1	25.40	250	300	339	406	580	696	787	944	900	1080	1220	1464
1-1/8	25.58	-	-	-	-	800	880	1085	1193	1280	1440	1736	1953
1-1/4	31.75	-	-	-	-	1120	1240	1519	1681	1820	2000	2468	2712
1-3/8	34.93	-	-	-	-	1460	1680	1980	2278	2380	2720	3227	3688
1-1/2	38.10	-	-	-	-	1940	2200	2631	2983	3160	3560	4285	4827

* Thick Nuts must be used with Grade 8 bolts

METRIC BOLT TORQUE SPECIFICATIONS

Size of Screw	Grade No.	Coarse Thread			Fine Thread		
		Pitch (mm)	Pounds Feet	Newton-Meters	Pitch (mm)	Pounds Feet	Newton-Meters
M6	5.6	1.0	3.6-5.8	4.9-7.9	-	-	-
	8.8		5.8-4	7.9-12.7		-	-
	10.9		7.2-10	9.8-13.6		-	-
M8	5.6	1.25	7.2-14	9.8-19	1.0	12-17	16.3-23
	8.8		17-22	23-29.8		19-27	25.7-36.6
	10.9		20-26	27.1-35.2		22-31	29.8-42
M10	5.6	1.5	20-25	27.1-33.9	1.25	20-29	27.1-39.3
	8.8		34-40	46.1-54.2		35-47	47.4-63.7
	10.9		38-46	51.5-62.3		40-52	54.2-70.5
M12	5.6	1.75	28-34	37.9-46.1	1.25	31-41	42-55.6
	8.8		51-59	69.1-79.9		56-68	75.9-92.1
	10.9		57-66	77.2-89.4		62-75	84-101.6
M14	5.6	2.0	49-56	66.4-75.9	1.5	52-64	70.5-86.7
	8.8		81-93	109.8-126		90-106	122-143.6
	10.9		96-109	130.1-147.7		107-124	145-168
M16	5.6	2.0	67-77	90.8-104.3	1.5	69-83	93.5-112.5
	8.8		116-130	157.2-176.2		120-138	162.6-187
	10.9		129-145	174.8-196.5		140-158	189.7-214.1
M18	5.6	2.0	88-100	119.2-136	1.5	100-117	136-158.5
	8.8		150-168	203.3-227.6		177-199	239.8-269.6
	10.9		175-194	237.1-262.9		202-231	273.7-313
M20	5.6	2.5	108-130	146.3-176.2	1.5	132-150	178.9-203.3
	8.8		186-205	252-277.8		206-242	279.1-327.9
	10.9		213-249	288.6-337.4		246-289	333.3-391.6

10360 6-8-95-2

SPECIFICATIONS

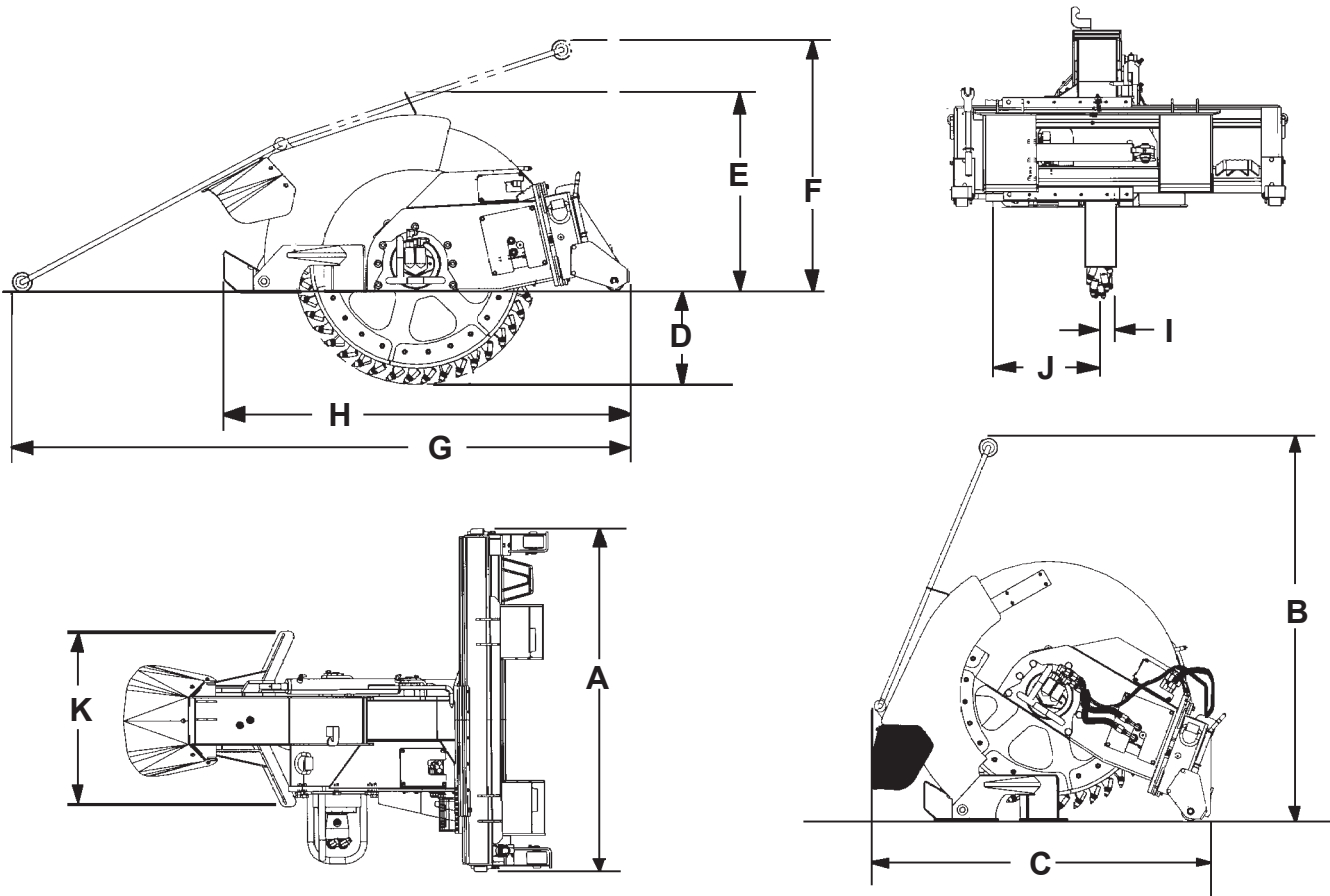

DESCRIPTION	RS18	RS24
A. Overall Width	67.00"	67.00"
B. Overall Transport Height	79.00"	81.00"
C. Overall Transport Length	76.00"	86.00"
D. Maximum Cutting Depth	18.00"	24.00"
E. Operating Height (guide arm down).....	39.50"	44.00"
F. Operating Height (guide arm up)	49.75"	58.00"
G. Operating Length (guide arm down)	119.00"	132.00"
H. Operating Length (guide arm up).....	77.00"	89.00"
I. Side Shift (center to left)	2.72"	2.72"
J. Side Shift (center to right)	24.00"	24.00"
K. Spoil Removal Path	34.00"	34.00"
Wheel Diameter	48.00"	60.00"
Number of Picks	42	56
Hydraulic Flow Requirement (GPM).....	31-33	35-39
Operating Pressure (PSI)	2500-3000	2500-3000
Weight (without picks)	1775#	2095#
Operating Weight (with 2.5" cutting width).....	1995#	2385#
Operating Weight (with 4.0" cutting width).....	2020#	2420#

LIMITED WARRANTY

All new Bradco products are warranted to be free from defects in materials or workmanship which may cause failure under normal usage and service when used for the purpose intended.

In the event of failure within twelve (12) months from initial retail sale, lease or rental date (excluding cable, ground engaging parts such as sprockets, digging chain, bearings, teeth, tamping and demolition heads, blade cutting edges, pilot bits, auger teeth, auger heads & broom bristles), if after examination, Bradco determines failure was due to defective material and/or workmanship, parts will be repaired or replaced. Bradco may request defective part or parts be returned prepaid to them for inspection at their place of business at Delhi, Iowa, or to a location specified by Bradco.

Any claims under this warranty must be made within fifteen (15) days after the Buyer learns of the facts upon which such claim is based. All claims not made in writing and received by Bradco within the time period specified above shall be deemed waived.

THIS WARRANTY IS IN LIEU OF ALL OTHER WARRANTIES EXPRESSED OR IMPLIED AND THERE ARE NO WARRANTIES OF MERCHANTABILITY OR OF FITNESS FOR A PARTICULAR PURPOSE. IN NO EVENT SHALL BRADCO BE LIABLE FOR CONSEQUENTIAL OR SPECIAL DAMAGE.

BRADCO'S LIABILITY FOR ANY AND ALL LOSSES AND DAMAGES TO BUYER, RESULTING FROM ANY CAUSE WHATSOEVER, INCLUDING BRADCO'S NEGLIGENCE, IRRESPECTIVE OF WHETHER SUCH DEFECTS ARE DISCOVERABLE OR LATENT, SHALL IN NO EVENT EXCEED THE PURCHASE PRICE OF THE PARTICULAR PRODUCTS WITH RESPECT TO WHICH LOSSES OR DAMAGES ARE CLAIMED, OR, AT THE ELECTION OF BRADCO, THE REPAIR OR REPLACEMENT OF DEFECTIVE OR DAMAGED PRODUCTS.

ROCK SAW ASSEMBLIES

18" ASSEMBLY #106657 / 24" ASSEMBLY #103380

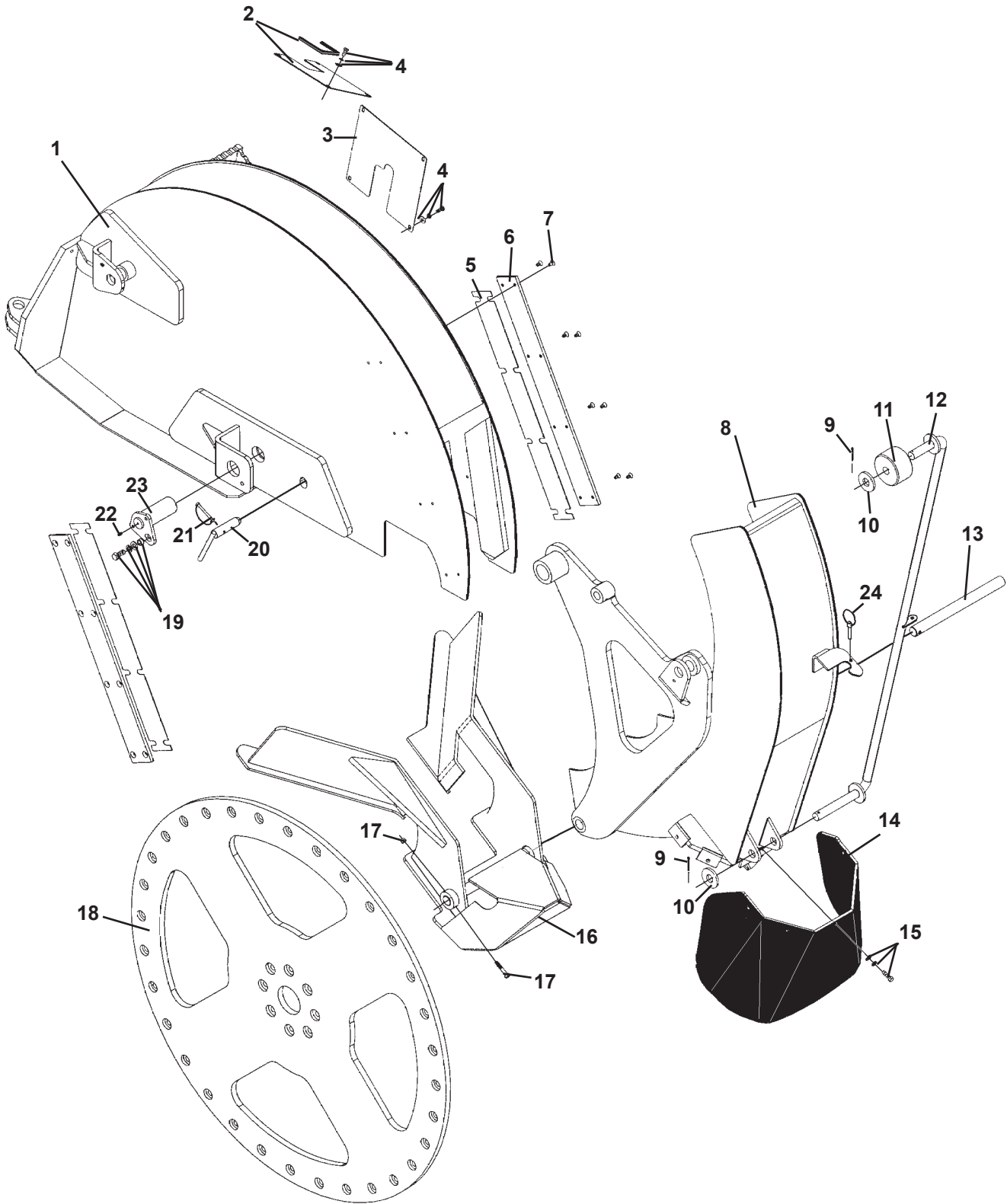

ROCK SAW ASSEMBLIES

18" ASSEMBLY #106657 / 24" ASSEMBLY #103380

<u>ITEM</u>	<u>REQ'D</u>	<u>PART NO.</u>	<u>DESCRIPTION</u>
1	1	106037	Mainframe (18" Rock Saw)
	1	103187	Mainframe (24" Rock Saw)
2	1	106842	Top Valve Cover
	1	34118	Rubber Edge
3	1	106843	Side Valve Cover
4	8	1021	.31" UNC X .75" Hex Capscrew
	8	1502	.31" Lock Washer
	8	1513	.31" Flat Washer
5	2	106679	Shim (18" Rock Saw)
	2	106789	Shim (24" Rock Saw)
6	2	25665	Wear Plate (18" Rock Saw)
	2	25666	Wear Plate (24" Rock Saw)
7	16	10082	.31" UNC X 62" Flat Head Screw
8	1	106735	Hood / Lift Arm (18" Rock Saw)
	1	106438	Hood / Lift Arm (24" Rock Saw)
9	2	1613	Cotter Pin
10	2	1520	1.00" Flat Washer
11	1	17671	Guide Wheel
12	1	103471	Guide Bar
13	1	104888	Pivot Pin (Hood / Skid Shoe) 1.25" x 14.75"
14	1	106456	Rubber Deflector
15	5	1044	.38" X 1.25" Hex Capscrew
	5	1503	.38" Lock Washer
	5	1514	.38" Flat Washer
16	1	106658	Skid Shoe (18" Rock Saw)
	1	104886	Skid Shoe (24" Rock Saw)
17	1	1050	.38" UNC X 2.75" Hex Capscrew
	1	1536	.38" UNC Nylock Nut
18	1	105982	Cutting Wheel (18" Rock Saw)
	1	103494	Cutting Wheel (24" Rock Saw)
19	1	1089	.50" UNC X 1.25" Hex Capscrew
	1	1505	.50" Lock Washer
	1	1516	.50" Flat Washer
	1	86149	Spacer Tube
20	1	106404	Locking Pin (Lift Arm)
21	1	106447	Snap Pin
22	1	6616	Grease Fitting
23	1	106003	Pivot Pin 2.00" x 4.81"
24	1	6626	Klik Pin

10533 5-12-06

ROCK SAW ASSEMBLIES

18" ASSEMBLY #106657 / 24" ASSEMBLY #103380

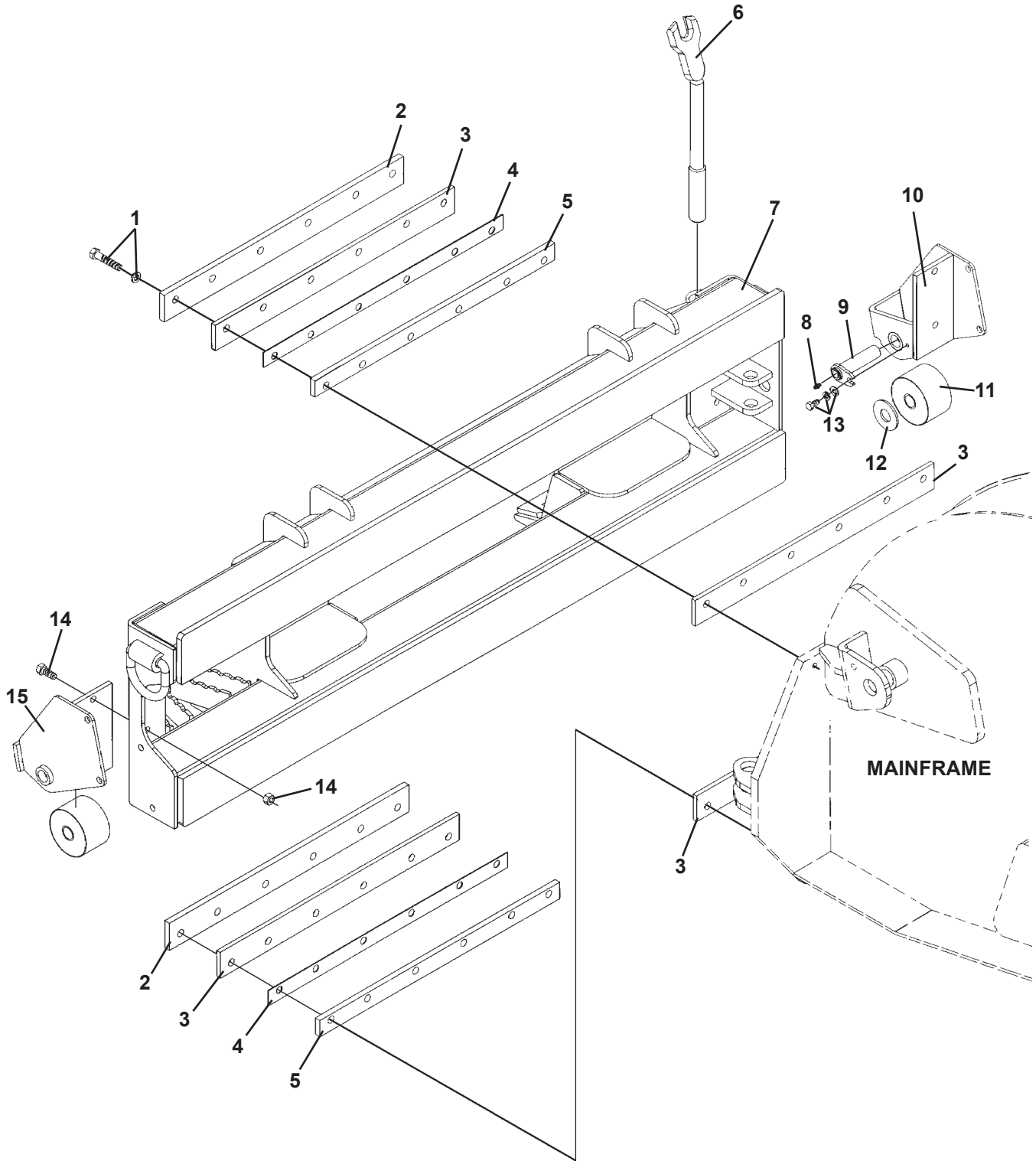

10534 3-13-06

ROCK SAW ASSEMBLIES

18" ASSEMBLY #106657 / 24" ASSEMBLY #103380

<u>ITEM</u>	<u>REQ'D</u>	<u>PART NO.</u>	<u>DESCRIPTION</u>
1	12	1818	.50" UNC X 2.75" Hex Capscrew
	12	1505	.50" Lock Washer
2	2	17757	Clamp Plate
3	4	89611	Wear Strip
4	2	89612	Shim
5	2	17758	Spacer Plate
6	1	100213	Extracting Tool (Pick Puller)
7	1	89501	Side Shift Frame
8	2	6616	Grease Fitting
9	2	17673	Pivot Pin
10	1	106022	Left Wheel Stand
11	2	17671	Wheel
12	2	57463	Washer
13	2	1042	.38" UNC X .75" Hex Capscrew
	2	1503	.38" Lock Washer
	2	1514	.38" Flat Washer
14	8	1089	.50" UNC X 1.25" Hex Capscrew
	8	1542	.50" UNC Nylock Nut
15	1	106023	Right Wheel Stand

10535 5-12-06

ROCK SAW ASSEMBLIES

18" ASSEMBLY #106657 / 24" ASSEMBLY #103380

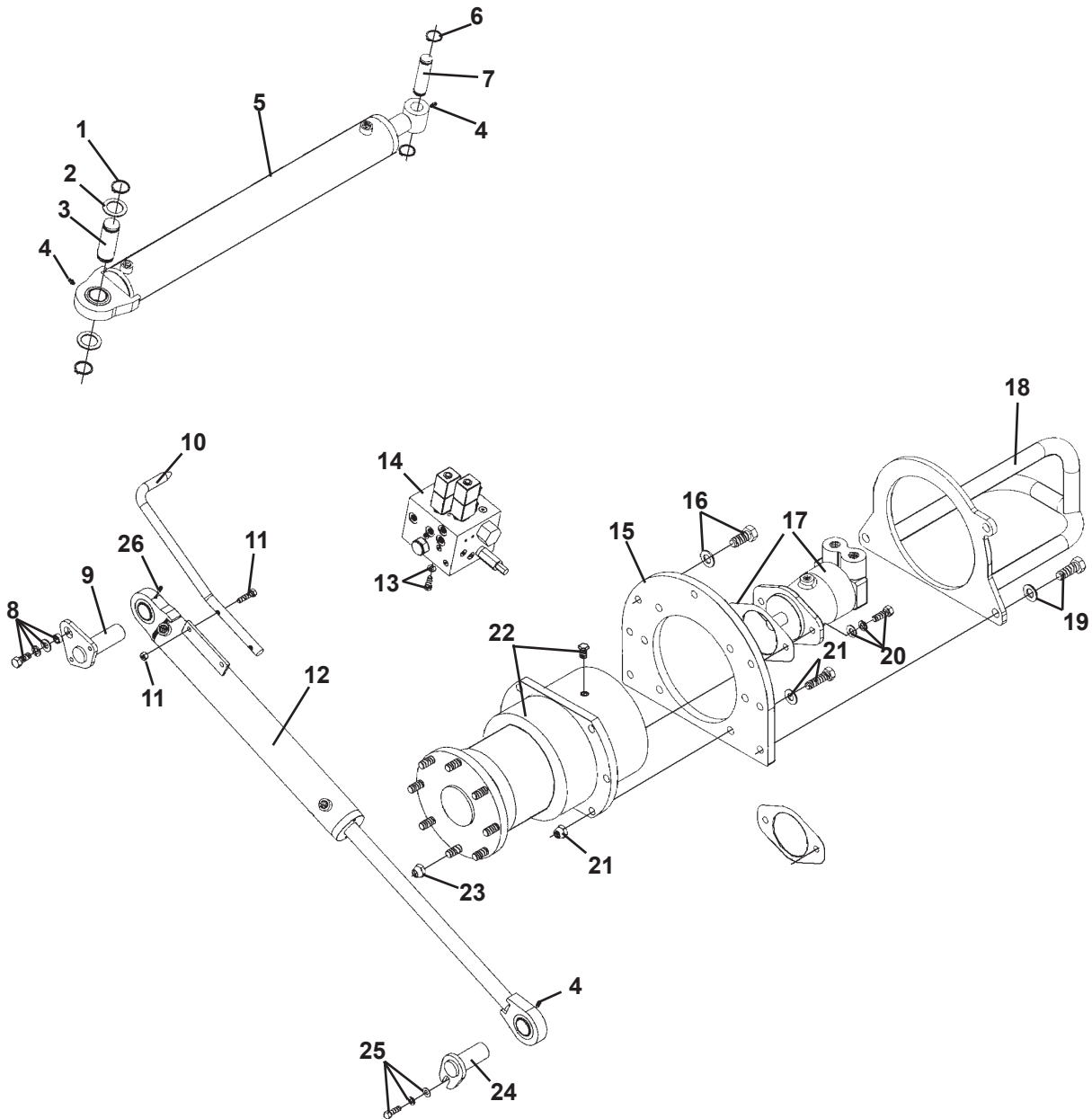

ROCK SAW ASSEMBLIES

18" ASSEMBLY #106657 / 24" ASSEMBLY #103380

<u>ITEM</u>	<u>REQ'D</u>	<u>PART NO.</u>	<u>DESCRIPTION</u>
1	2	1650	Snap Ring
2	2	64725	Thrust Washer
3	1	89006	Cylinder Pivot Pin 1.38" X 3.06
4	4	6616	Grease Fitting
5	1	105966	Side Shift Cylinder Assembly
6	2	6612	Snap Ring
7	1	89978	Cylinder Pivot Pin 1.00" x 3.25"
8	1	1089	.50" UNC X 1.25" Hex Capscrew
	1	1505	.50" Lock Washer
	1	1516	.50" Flat Washer
	1	89149	Spacer Tube
9	1	103468	Cylinder Pivot Pin 1.38" x 4.12"
10	1	106455	Depth Indicator
11	2	1045	.38" UNC X 1.50" Hex Capscrew
	2	1536	.38" UNC Nylock Nut
12	1	106420	Lift Cylinder Assembly
13	3	1043	.38" UNC X 1.00" Hex Capscrew
	3	1503	.38" Lock Washer
14	1	101395	Control Valve
15	1	103394	Planetary Mounting Plate
16	4	1138	.75" UNC X 1.75" Hex Capscrew
	4	1649	.75" Hard Flat Washer
17	1	17777	Hydraulic Motor (29-35 GPM) (Not available on 24" Saw)
	1	17778	Hydraulic Motor (36-44 GPM)
	1	102594	Motor Gasket
	**	45845	Replacement Motor Seal Kit
18	1	106237	Motor Guard
19	3	1139	.75" UNC X 2.00" Hex Capscrew
	3	1649	.75" Hard Flat Washer
20	2	1090	.50" UNC X 1.50" Hex Capscrew
	2	1505	.50" Lock Washer
	2	1646	.50" Hard Flat Washer
21	6	1118	.62" UNC X 2.50" Hex Capscrew
	6	1627	.62" Hard Flat Washer
	6	1839	.62" UNC Deformed Lock Nut
22	1	103384	Planetary (18" Rock Saw)
	1	103383	Planetary (24" Rock Saw)
	1	3227	Fill Plug
	-	45903	Replacement Planetary Shaft Seal
23	8	10003	.62" UNC Deformed Lock Nut (Included with Planetary)
24	1	103486	Cylinder Pivot Pin 1.38" x 3.13"
25	1	1043	.38" UNC X 1.00" Hex Capscrew
	1	1503	.38" Lock Washer
	1	1514	.38" Flat Washer
26	1	84688	45° Grease Fitting

** Field replacement of internal motor seals voids warranty.

10537 5-12-06

ROCK SAW ASSEMBLIES

18" ASSEMBLY #106657 / 24" ASSEMBLY #103380

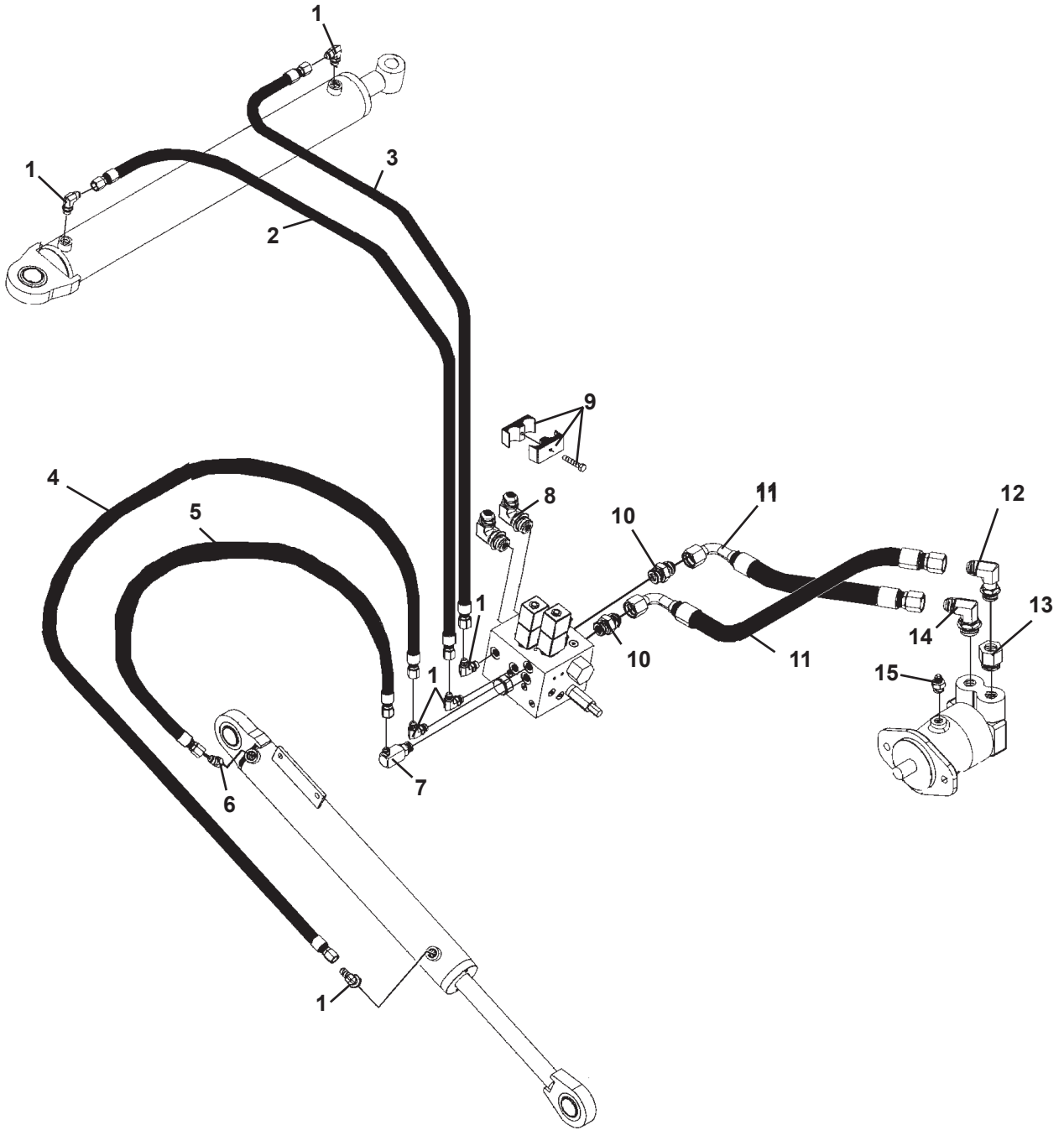

ROCK SAW ASSEMBLIES

18" ASSEMBLY #106657 / 24" ASSEMBLY #103380

<u>ITEM</u>	<u>REQ'D</u>	<u>PART NO.</u>	<u>DESCRIPTION</u>
1	6	3434	90° Elbow 6MBo-6MJ
2	1	37024	Hose .25" X 48" 6FJX-6FJX
3	1	38325	Hose .25" X 22" 6FJX-6FJX
4	1	37750	Hose .25" X 66" 6FJX-6FJX
5	1	38115	Hose .25" X 44" 6FJX-6FJX
6	1	30313	45° Elbow 6MBo-6MJ
7	1	30140	90° Elbow - Long 6MBo-6MJ
8	2	22600	90° Elbow 12MBo-12MJ (To Power and Return)
9	1	22317	Hose Clamp (Included on Mainframe)
	1	1027	.31" UNC X 2.25" Hex Capscrew
	1	1502	.31" Lock Washer
	1	1524	.31" Flat Washer
10	2	3419	Straight Connector 12MBo-12MJ
11	2	38469	Hose .75" X 26" 12FJX-12FJX 90°
12	1	30347	90° Elbow - Long 12MBo-12MJ
13	1	30292	Straight Connector 16MBo-12FBo
14	1	30051	90° Elbow 16MBo-12MJ
15	1	3269	Straight Connector 8MBo-6MJ (To Case Drain)

PICK AND HOLDER ASSEMBLIES

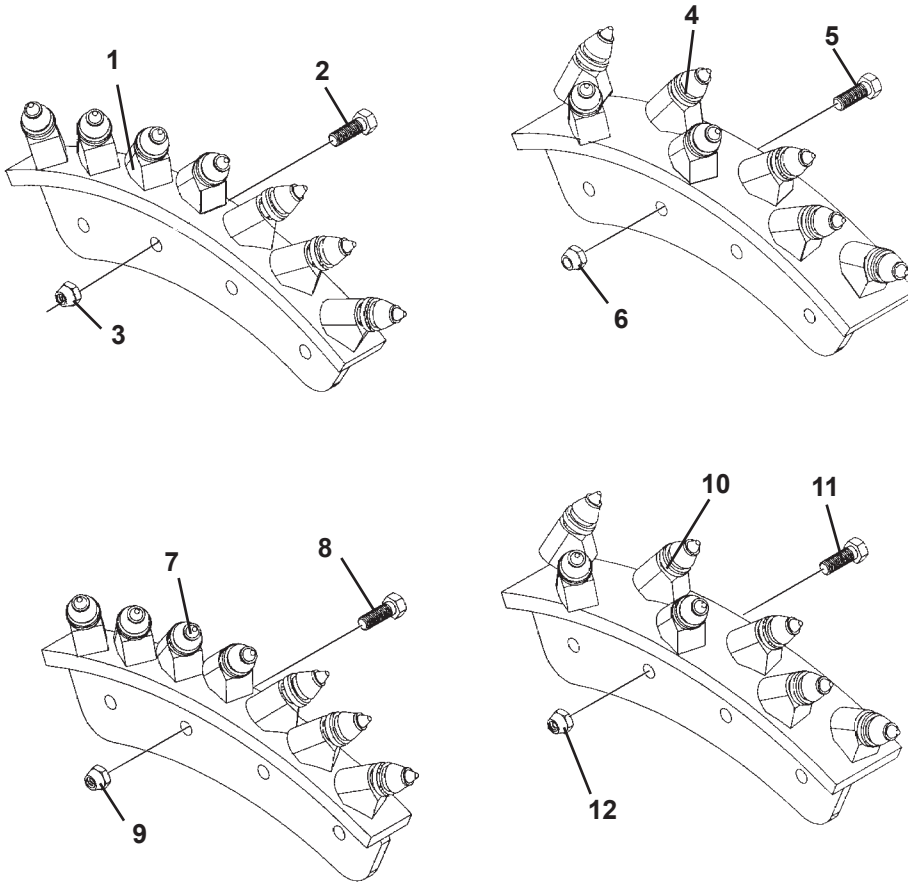

PICK AND HOLDER ASSEMBLIES

#106681 - 2.50" CUT PICK ASSEMBLY FOR 18" ROCK SAW (Includes Items 1-3)

<u>ITEM</u>	<u>REQ'D</u>	<u>PART NO.</u>	<u>DESCRIPTION</u>
1	6	105984	2.5" Pick and Holder
2	24	10070	.62" UNC X 1.75" Hex Capscrew - Grade 8
3	24	1839	.62" UNC Deformed Lock Nut

#106682 - 4.00" CUT PICK ASSEMBLY FOR 18" ROCK SAW (Includes Items 4-6)

<u>ITEM</u>	<u>REQ'D</u>	<u>PART NO.</u>	<u>DESCRIPTION</u>
4	6	106266	4.00" Pick and Holder
5	24	10070	.62" UNC X 1.75" Hex Capscrew - Grade 8
6	24	1839	.62" UNC Deformed Lock Nut

#106684 - 2.50" CUT PICK ASSEMBLY FOR 24" ROCK SAW (Includes Items 7-9)

<u>ITEM</u>	<u>REQ'D</u>	<u>PART NO.</u>	<u>DESCRIPTION</u>
7	8	103480	2.5" Pick and Holder
8	32	10070	.62" UNC X 1.75" Hex Capscrew - Grade 8
9	32	1839	.62" UNC Deformed Lock Nut

#106685 - 4.00" CUT PICK ASSEMBLY FOR 24" ROCK SAW (Includes Items 10-12)

<u>ITEM</u>	<u>REQ'D</u>	<u>PART NO.</u>	<u>DESCRIPTION</u>
10	8	106263	4.00" Pick and Holder
11	32	10070	.62" UNC X 1.75" Hex Capscrew - Grade 8
12	32	1839	.62" UNC Deformed Lock Nut

Replacement Picks (50 General Purpose Picks) #102058

Replacement Picks (50 Concrete Picks) @102059

HYDRAULIC ASSEMBLIES

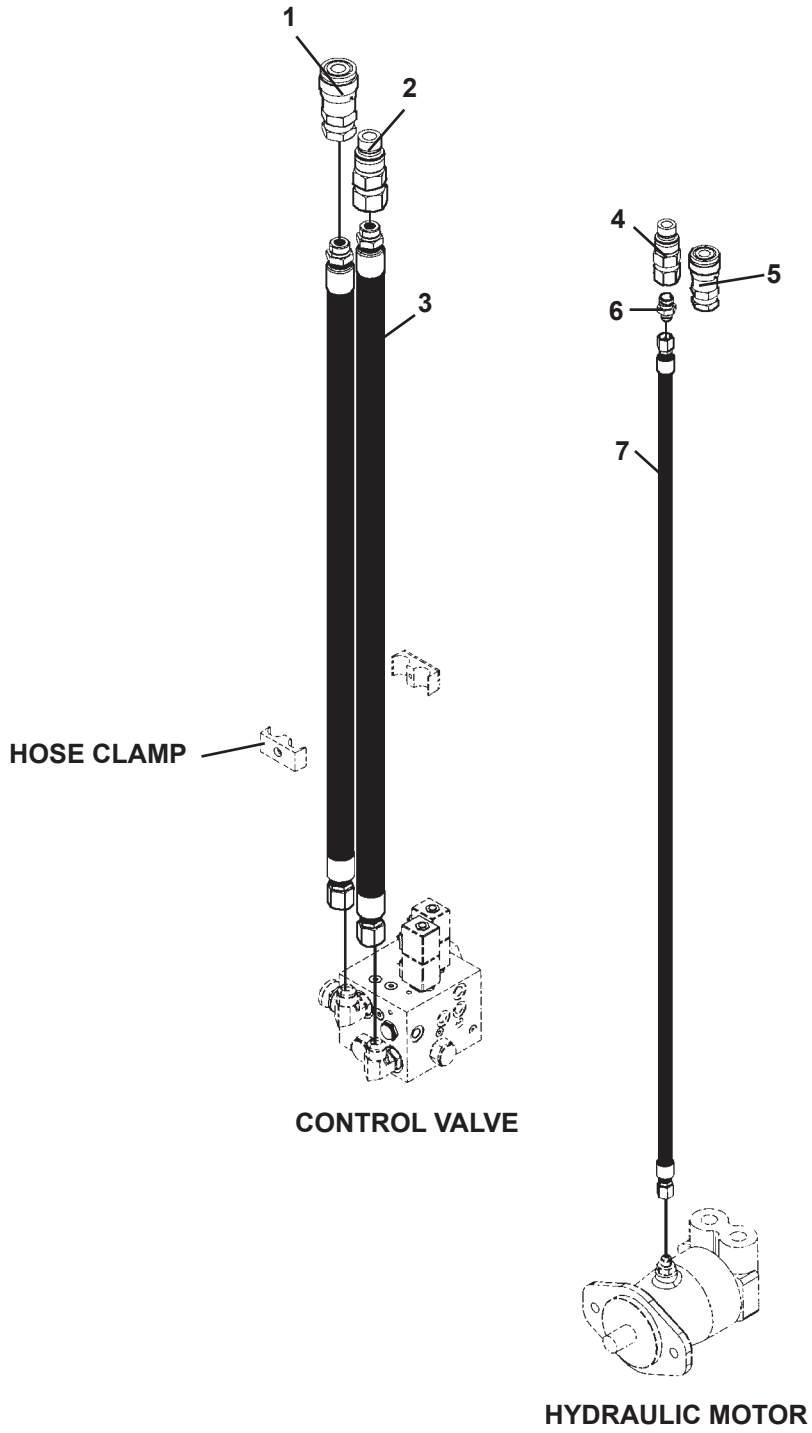

HYDRAULIC ASSEMBLIES

<u>ITEM</u>	<u>REQ'D</u>	<u>PART NO.</u>	<u>DESCRIPTION</u>
1	1	22518	Female Coupler 12FBo (1/2" Body)
	-	84921	Female Coupler 12FBo (5/8" Body)
	-	22520	Female Coupler 12FBo (3/4" Body)
2	1	19632	Male Coupler 12FBo (1/2" Body)
	-	19636	Male Coupler 12FBo (5/8" Body)
	-	19638	Male Coupler 12FBo (3/4" Body)
3	2	37060	Hose .75" X 88" 12FJX-12MBo
	-	23532	Hose .75" X 106" 12FJX-12MBo
4	1	84923	Male Case Drain Coupler 8FBo (3/8" Body)
5	1	84928	Female Case Drain Coupler 8FBo (3/8" Body)
6	1	3269	Straight Connector 8MBo-6MJ
7	1	35699	Hose .25" X 106" 6JFX-6FJX
	-	35813	Hose .25" X 125" 6FJX-6FJX
NOT SHOWN	2	84770	Hose Tie

CYLINDER ASSEMBLY

ASSEMBLY #106420

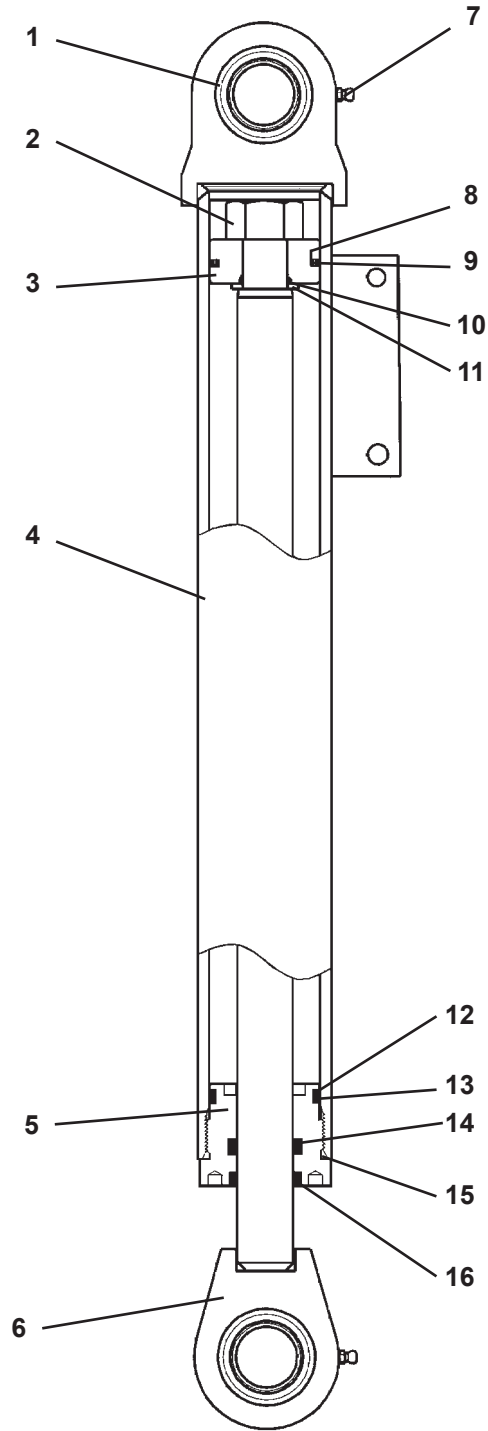

CYLINDER ASSEMBLY

ASSEMBLY #106420

<u>ITEM</u>	<u>REQ'D</u>	<u>PART NO.</u>	<u>DESCRIPTION</u>
1	2	6615	Self-Aligning Bushing
2	1	1483	Hex Nut
3	1	50252	Piston
4	1	106421	Cylinder Tube
5	1	77458	Cylinder Gland
6	1	81636	Cylinder Rod
7	2	6616	Grease Fitting
8	1	4645*	O'Ring
9	1	4644*	Piston Ring
10	1	4641*	O'Ring
11	1	5421	Washer
12	1	4509*	O'Ring
13	1	4510*	Back-Up Washer
14	1	45219*	Poly-Pak Seal
15	1	45250*	O'Ring
16	1	45389*	Rod Wiper

NOTE: Seal Kit #45617 includes all parts marked with an asterisk(*). Parts are not sold separately.

10561 3-20-06

CYLINDER ASSEMBLY

ASSEMBLY #105966

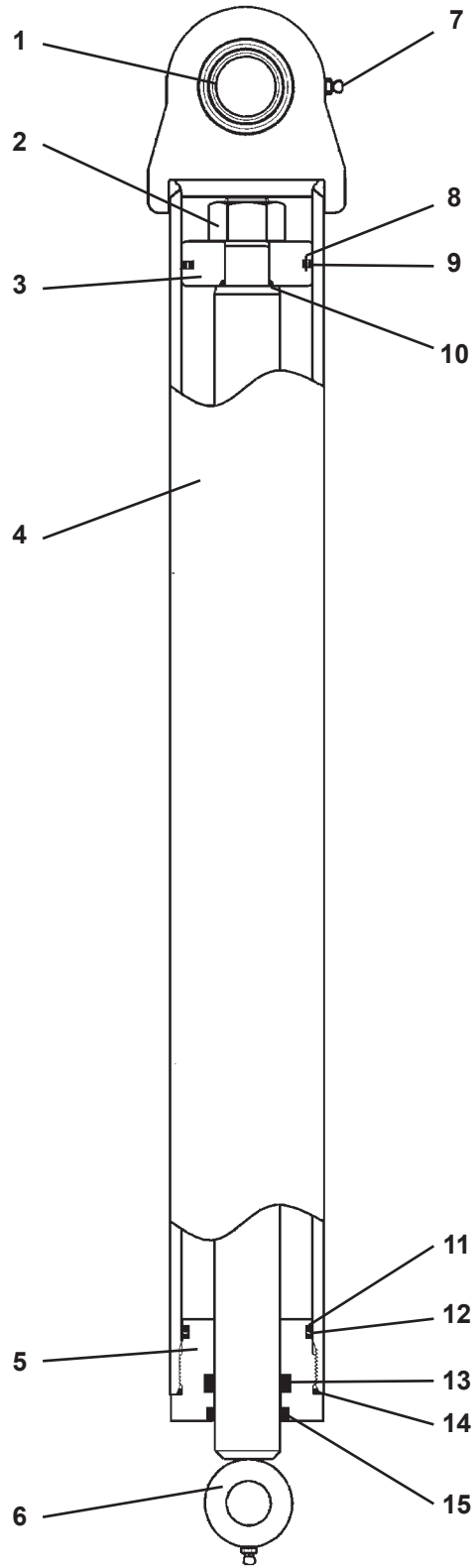

CYLINDER ASSEMBLY

ASSEMBLY #105966

<u>ITEM</u>	<u>REQ'D</u>	<u>PART NO.</u>	<u>DESCRIPTION</u>
1	1	6615	Self-Aligning Bushing
2	1	1483	Hex Nut
3	1	6731	Piston
4	1	105967	Cylinder Tube
5	1	77445	Cylinder Gland
6	1	89537	Cylinder Rod
7	2	6616	Grease Fitting
8	1	4570*	O'Ring
9	1	4569*	Piston Ring
10	1	4641*	O'Ring
11	1	45555*	O'Ring
12	1	4631*	Back-Up Washer
13	1	45225*	Poly-Pak Seal
14	1	4908*	O'Ring
15	1	45372*	Rod Wiper

NOTE: Seal Kit #45550 includes all parts marked with an asterisk(*). Parts are not sold separately.

10557 3-20-06

CONTROL BOX ASSEMBLY

BRADCO ELECTRICAL CONTROL HANDLE ASSEMBLY #104367
(DIRECT CONNECT TO CONTROL VALVE)

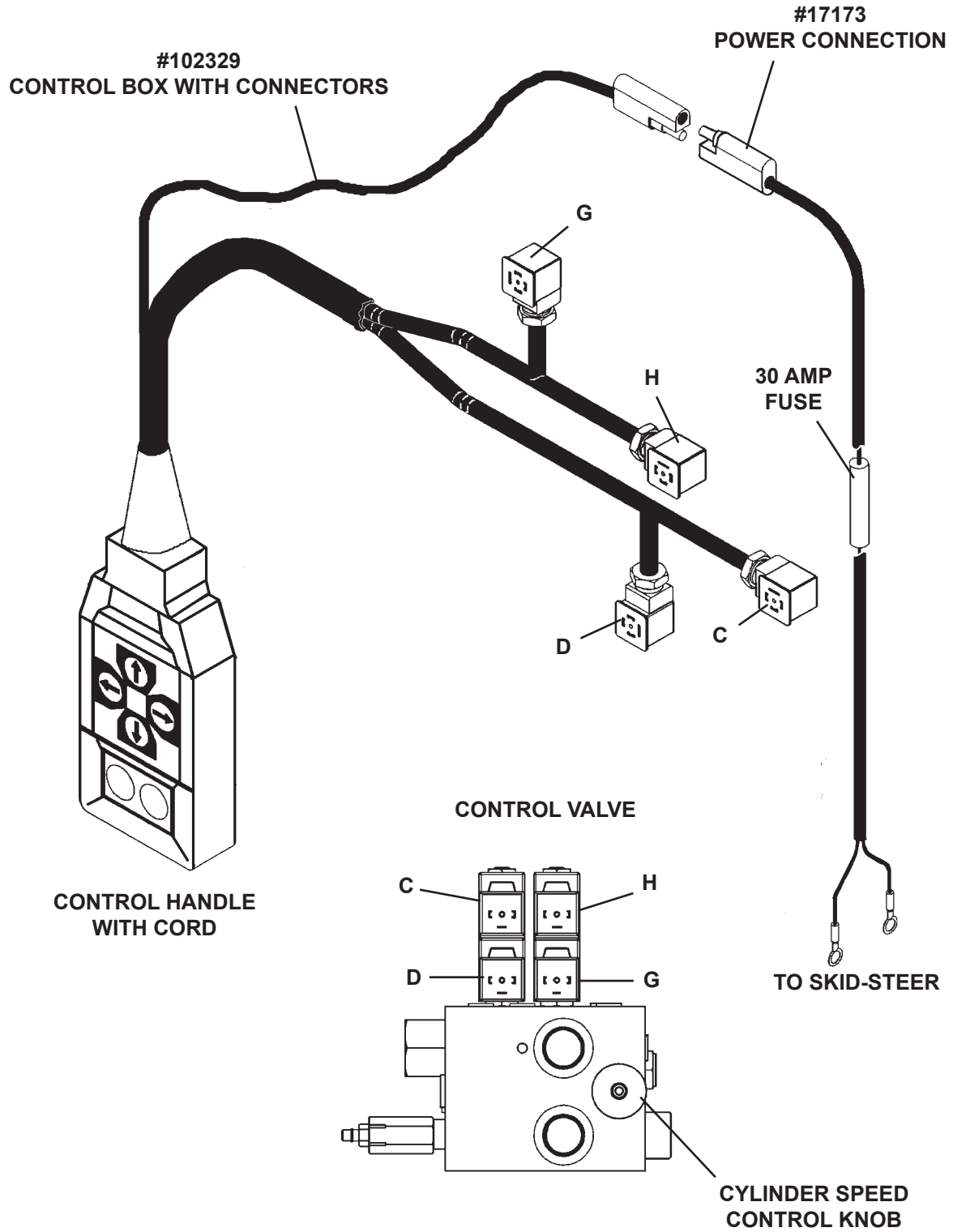

ELECTRICAL HARNESS

WIRING HARNESS #101096

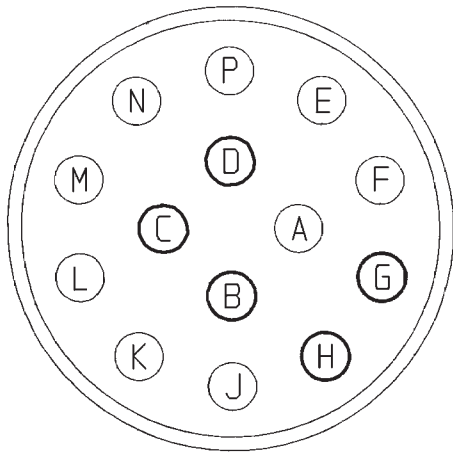

DEUTSCH CONNECTOR PIN DETAIL

- B = BLACK (GROUND)
- C = DARK GREEN (SWING - LEFT)
- D = BROWN (SWING - RIGHT)
- G = RED (LIFT - DOWN)
- H = YELLOW (LIFT - UP)

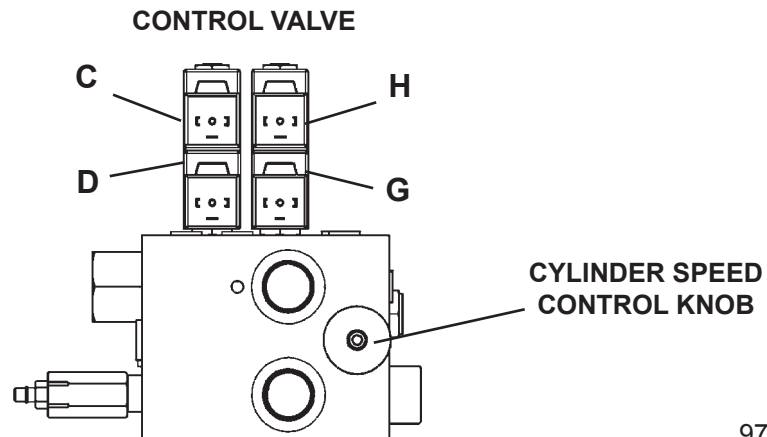
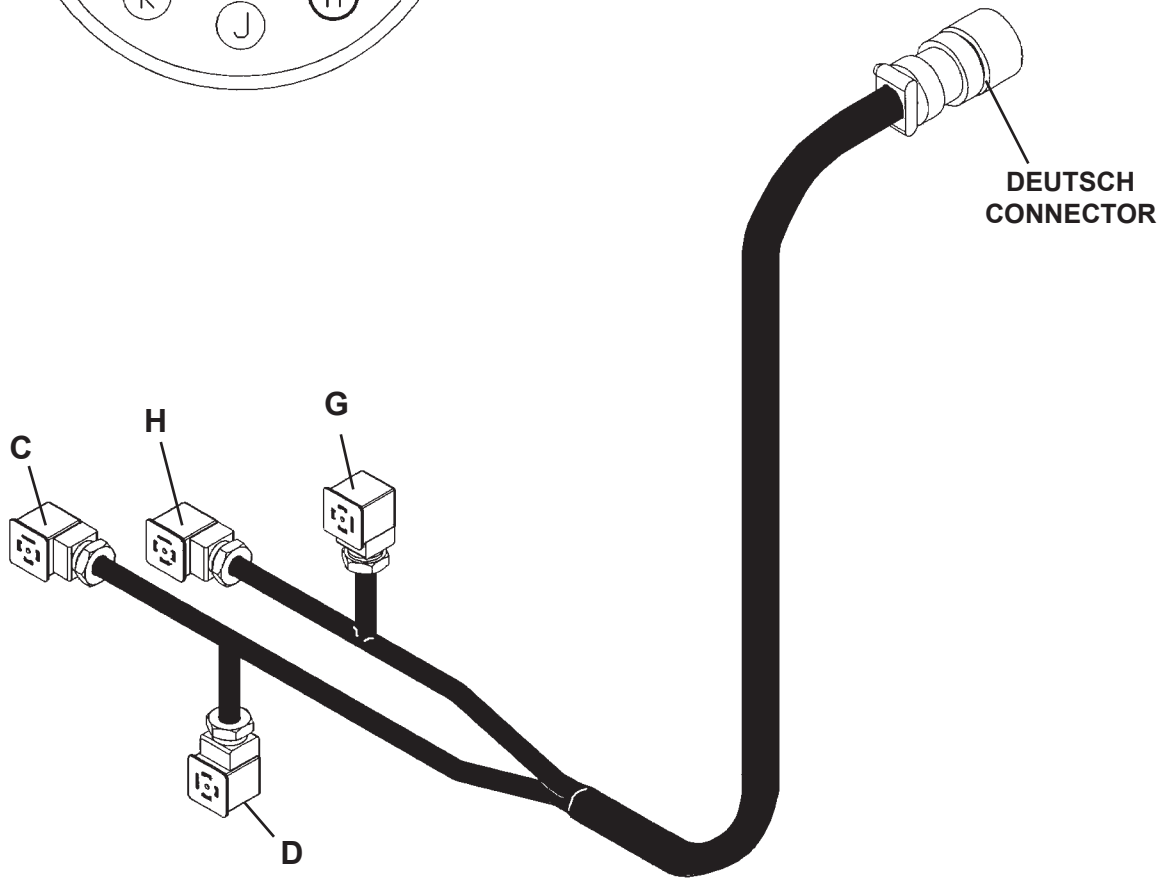

9709 3-15-06-2

CONTROL BOX ASSEMBLY

OPTIONAL ELELCTRICAL CONTROL BOX ASSEMBLY #104368
(USE WITH WIRING HARNESS #101096)

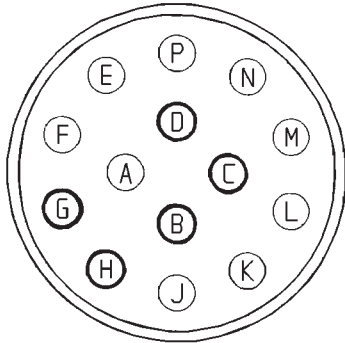

DEUTSCH CONNECTOR PIN DETAIL

- B = BLACK (GROUND)
- C = DARK GREEN (SWING - LEFT)
- D = BROWN (SWING - RIGHT)
- G = ORANGE (LIFT - DOWN)
- H = YELLOW (LIFT - UP)

