



OPERATOR'S AND PARTS MANUAL SG26 & SG30 STUMP GRINDER



PALADIN LIGHT CONSTRUCTION

**UNIVERSAL SKID STEER
APPLICATIONS**



SERIAL NUMBER: _____

MODEL NUMBER: _____

Manual Number: OM678
Part Number: 75578
Rev. 4

TABLE OF CONTENTS

TO THE OWNER.....	A
SAFETY PRECAUTIONS	B
General Information	
To The Operator	
Before You Start	
Working With The Stump Grinder	
Transporting The Stump Grinder	
Maintenance	
INTERNATIONAL SYMBOLS.....	C
PREOPERATION	D
Before Operation	
Skid Steer	
Nomenclature	
STUMP GRINDER ASSEMBLIES	E
Stump Grinder Assembly #100318	
Rear Guard Assembly #101742	
Wheel Assemblies	
Hydraulic Valve Assembly #100982	
Control Valve Replacement Parts	
Standard Flow Drive Assembly #100415	
High Flow Drive Assembly #100417	
Power and Return Circuit	
Cylinder Assembly #100324	
Cylinder Assembly #101245	
Electrical Schematics - Control Handles (#104367 - Direct & #104368 - use with #101096)	
Electrical Schematics - Wiring Harness's (#101096 - 14 Pin, #108035 - 8 Pin & #108036 - 14 Pin JD)	
INSTALLATION INSTRUCTIONS.....	F
OPERATING INSTRUCTIONS	G
LUBRICATION	H
MAINTENANCE	L
Daily / Every 40 Hours	
Replacing Teeth	
Replacing Hydraulic Motor	
Replacing Gearbox / Motor Coupler	
Replacing Gearbox	
Cylinder Seal Replacement	
STORAGE AND TRANSPORTING	M
TROUBLESHOOTING	N
BOLT TORQUE SPECIFICATION	O
SPECIFICATIONS.....	P
DECALS.....	Q
PREDELIVERY CHECKLIST.....	R
LIMITED WARRANTY	S

TO THE OWNER

GENERAL COMMENTS

Congratulations on the purchase of your new BRADCO product! This product was carefully designed and manufactured to give you years of dependable service. Only minor maintenance (such as cleaning and lubricating) is required to keep it in top working condition. Be sure to observe all safety precautions and maintenance procedures, as described in this manual.

ABOUT THIS MANUAL

This manual has been designed to help you do a better, safer job. Read this manual carefully and become familiar with its contents. **Remember, never let anyone operate this unit without reading the "Safety Precautions" and "Operating Instructions" sections of this manual. (See Sections B and G respectively.)**

Unless noted otherwise, right and left sides are determined from the position of the operator when behind the product facing forward.

SAFETY ALERT SYMBOL



This is the "Safety Alert Symbol" used by this industry. This symbol is used to warn of possible injury. Be sure to read all warnings carefully. They are included for your safety and for the safety of others working with you.

SERVICE

When servicing your product, remember to use only manufacturer replacement parts. Substitute parts may not meet the standards required for safe, dependable operation.

To facilitate parts ordering, record the model and serial number of your unit in the space provided on this page. This information may be obtained from the identification plate located on the product.

MODEL _____
SERIAL NUMBER _____
DATE PURCHASED _____

The parts department needs this information to insure that you receive the correct parts for your specific model.

SAFETY PRECAUTIONS

TAKE NOTE! THIS SAFETY ALERT SYMBOL FOUND THROUGHOUT THIS MANUAL IS USED TO CALL YOUR ATTENTION TO INSTRUCTIONS INVOLVING YOUR PERSONAL SAFETY OR OTHERS. FAILURE TO FOLLOW THESE INSTRUCTIONS CAN RESULT IN INJURY OR DEATH.



THIS SYMBOL MEANS:

ATTENTION!

BECOME ALERT!

YOUR SAFETY IS INVOLVED!

SIGNAL WORDS: Note the use of signal words DANGER, WARNING, and CAUTION with the safety messages. The appropriate signal word for each has been selected using the following guidelines:

DANGER: Indicates an imminently hazardous situation, which if not avoided, will result in death or serious injury. This signal word is to be limited to the most extreme situations, **typically for machine components which, for functional purposes, cannot be guarded.**

WARNING: Indicates a potentially hazardous situation, which if not avoided, could result in death or serious injury, and **includes hazards that are exposed when guards are removed. It may also be used to alert against unsafe practices.**

CAUTION: Indicates a potentially hazardous situation, which if not avoided, **may result in minor or moderate injury. It may also be used to alert against unsafe practices.**

SAFETY PRECAUTIONS

BRADCO STUMP GRINDER

GENERAL INFORMATION

This section is composed of various warnings and safety tips. **Read and learn all the information in this section before you attempt to use your BRADCO STUMP GRINDER.** Also read your vehicle owner's manual before using your equipment. This knowledge will help you operate your unit safely. **Do not take this information lightly, it is presented for your benefit and for the benefit of others working around you.**

The "Safety Alert Symbol" (as described in Section A and at the beginning of Section B) will be used throughout this manual. It will appear with the word **DANGER, WARNING, or CAUTION** above it, and a safety message pertaining to the specific topic being covered. Take the time to read these messages as you come across them.

TO THE OPERATOR

The primary responsibility for safety with the equipment falls to the operator. Make sure that the equipment is operated only by responsible & competent individuals with the proper instruction. It is the skill, care, common sense, and good judgement of the operator that will determine how efficiently and safely the job is performed. Know your equipment before you start. Know its capabilities dimensions, and how to operate all the controls. Visually inspect your equipment before you start and never operate equipment that is not in proper working order.

BEFORE YOU START

1. **Read the entire loader and Stump Grinder manual.** This knowledge is necessary for safe operation.
2. **Do NOT operate the standard flow stump grinder on high flow hydraulic systems. Severe injury could occur due to the increased RPM.**
3. **Always wear safety goggles and hearing protection** during operation, and make sure **ALL** safety shields are properly installed.
4. **Follow all safety decals.** Keep them clean and replace them if they become worn, damaged or illegible.
5. **Do not paint over,** remove or deface any safety signs or warning decals on your equipment.
6. **Know your equipment inside and out.** Know how to operate all controls and know emergency shut down procedures.
7. **Keep all stepping surfaces, pedals, and controls free from dirt, grease and oil.** Keep equipment clean to help avoid injury from a fall when getting on or off equipment.
8. **Use handholds and step plates when getting on/off .** Failure to do so could cause a fall.

SAFETY PRECAUTIONS

BRADCO STUMP GRINDER

9. **Never operate the unit near bystanders, traffic, pets, livestock or buildings.** Be sure others know when and where you will be working. Never direct discharge towards people, animals or property. Never allow anyone to approach the stump grinder when in operation.
10. **Never take passengers on your equipment.** There is no safe place for a passenger.
11. **Never try to board equipment while it is running.**
12. **Turn off engine, remove the key and disconnect hydraulic couplers before performing maintenance.** If unit must be left raised for maintenance or any other reason, block the unit securely to prevent accidental release of the lifting mechanism. Serious damage or personal injury could result.
13. **Never leave the unit unattended when in a raised position.** Always make sure the attachment is on the ground and keys removed before leaving the unit unattended.
14. **Test all controls before you begin.**
15. **Do not smoke when refueling.** Allow room in the gas tank for expansion. Wipe up any spilt fuel. Secure cap tightly when done.

WORKING WITH THE STUMP GRINDER

1. **Never operate the unit without first reading and understanding the operator's manual.**
2. **Operate the unit only in daylight or sufficient artificial light.**
3. **Do not carry load with arms in the raised position.** Always carry loads as close as possible to the ground.
4. **Check your work area and know where all utility lines are.** Avoid hitting underground electrical wires, cables, pipes, fence posts, gas lines, uneven sidewalk edges, large rocks, etc.
5. **Never operate equipment while under the influence** of alcohol, prescription drugs, nonprescription drugs, or illegal drugs which could inhibit physical and/or mental capacity.
6. **Do not exceed rated operating capacity, as machine may become unstable which may result in loss of control.**
7. **Do not operate the unit without covers installed.**
8. **Keep hands, feet, hair and clothing away from equipment with engine running. Stay clear of all moving parts.**
9. **Do not raise the attachment when the grinding wheel is rotating.**
10. **ALWAYS LOWER THE LOADER ARMS TO THE GROUND, SHUT OFF THE ENGINE AND REMOVE THE KEY BEFORE GETTING OFF THE UNIT.**

SAFETY PRECAUTIONS

BRADCO STUMP GRINDER

TRANSPORTING THE STUMP GRINDER

1. Follow all federal, state and local regulations when transporting the unit on public roads.
2. Use extra care when loading or unloading the machine onto a truck or trailer. Disconnect hydraulic couplers during transportation.

MAINTENANCE

1. Never work on equipment while it is running. Always lower the loader arms to the ground, shut off the engine, remove the key and disconnect hydraulic couplers before performing maintenance on the unit.
2. Never make hydraulic repairs while the system is under pressure. Injury or death could result.
3. Observe proper maintenance schedules and repairs to keep the unit in safe working order.
4. Always wear safety goggles or glasses when working on equipment.
5. Use only manufacturer recommended replacement parts. Other parts may be substandard in fit and quality.

WARNING! Escaping fluid under pressure can have sufficient force to penetrate the skin causing serious personal injury. Fluid escaping from a very small hole can be almost invisible. Use a piece of cardboard or wood, rather than hands to search for suspected leaks. Keep unprotected body parts, such as face, eyes, and arms as far away as possible from a suspected leak. Flesh injected with hydraulic fluid may develop gangrene or other permanent disabilities. If injured by injected fluid, see a doctor at once. If your doctor is not familiar with this type of injury, ask him to research it immediately to determine proper treatment.

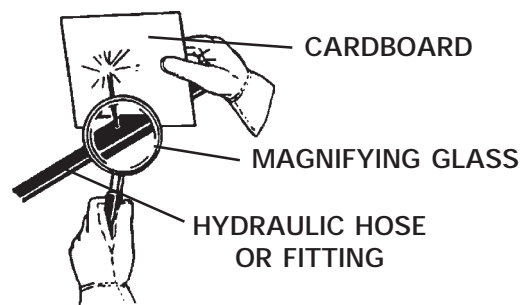

INTERNATIONAL SYMBOLS

As a guide to the operation of your equipment, various international symbols have been utilized on the instruments and controls. The symbols are shown below with an indication of their meaning.

	Engine speed		Alternator charge
	Hours recorded		Power take-off (on)
	Engine water temperature		Power take-off (off)
	Lights		"Tortoise," slow or minimum setting
	Horn		"Hare," fast or maximum setting
	Engine oil pressure		Caution
	Hazard warning		Control lever operating direction
	Axle connect		Rock shaft (raised)
	Axle disconnect		Rock shaft (lowered)
	Continuously variable		Remote cylinder (extended)
	Increase		Remote cylinder (retracted)
	Decrease		Remote cylinder (FLOAT)
	Diesel fuel		Differential lock
	Creeper range		Read operators manual
	High range		Neutral
	Low range		Forward
			Reverse

PREOPERATION

STUMP GRINDER

GENERAL INFORMATION

The BRADCO Stump Grinders were designed to be easy to use and maintain. They are operated by the skid-steer auxiliary hydraulics and mount to the quick attach mechanism for easy operator hook-up. There are two models of BRADCO stump grinders available, standard flow and high flow. These will allow mounting the stump grinder to most skid-steer loaders.

Unless noted otherwise, right and left are determined from the position of the skid-steer operator sitting in the operator's seat facing forward.

Remember to read the "Safety Precautions" and "Operating Instructions" sections of the manual BEFORE you attempt to install or use the Stump Grinder.

NOTE: Illustrations and data used in this manual were current (according to the information available to us) at the time of printing, however, we reserve the right to redesign and change the grinders as may be necessary without notification.

BEFORE OPERATION

The primary responsibility for safety with this equipment falls to the operator. Make sure that the equipment is operated only by trained individuals that have read and understand this manual. Don't hurry the learning process or take the unit for granted. Practice the operation of your new equipment and become familiar with the controls and the way it handles on your machine.

If there is any portion of this manual or function you do not understand, contact your local authorized dealer or manufacturer.

SKID-STEER

Your skid-steer must be equipped with auxiliary hydraulic and an electric control kit (or the optional electric control handle must be ordered from your BRADCO dealer).

There are two models of BRADCO stump grinders available, standard flow and high flow. Be sure the stump grinder you have purchased matches the hydraulic flow of your skid-steer.

The standard flow unit requires 15-22 GPM and the high flow requires 25-42 GPM. Operating the high flow stump grinder on a standard flow skid-steer will result in poor performance.

WARNING!  **OPERATING THE STANDARD FLOW STUMP GRINDER ON A HIGH FLOW HYDRAULIC SYSTEM MAY CAUSE SEVERE INJURY OR DEATH TO THE OPERATOR OR BYSTANDERS DUE TO THE INCREASED RPM.**

PREOPERATION

STUMP GRINDER

NOMENCLATURE

Throughout this manual, reference is made to various stump grinder components. The purpose of this page is to acquaint you with the various names of these components. This knowledge will be helpful when reading through this manual or when ordering service parts.

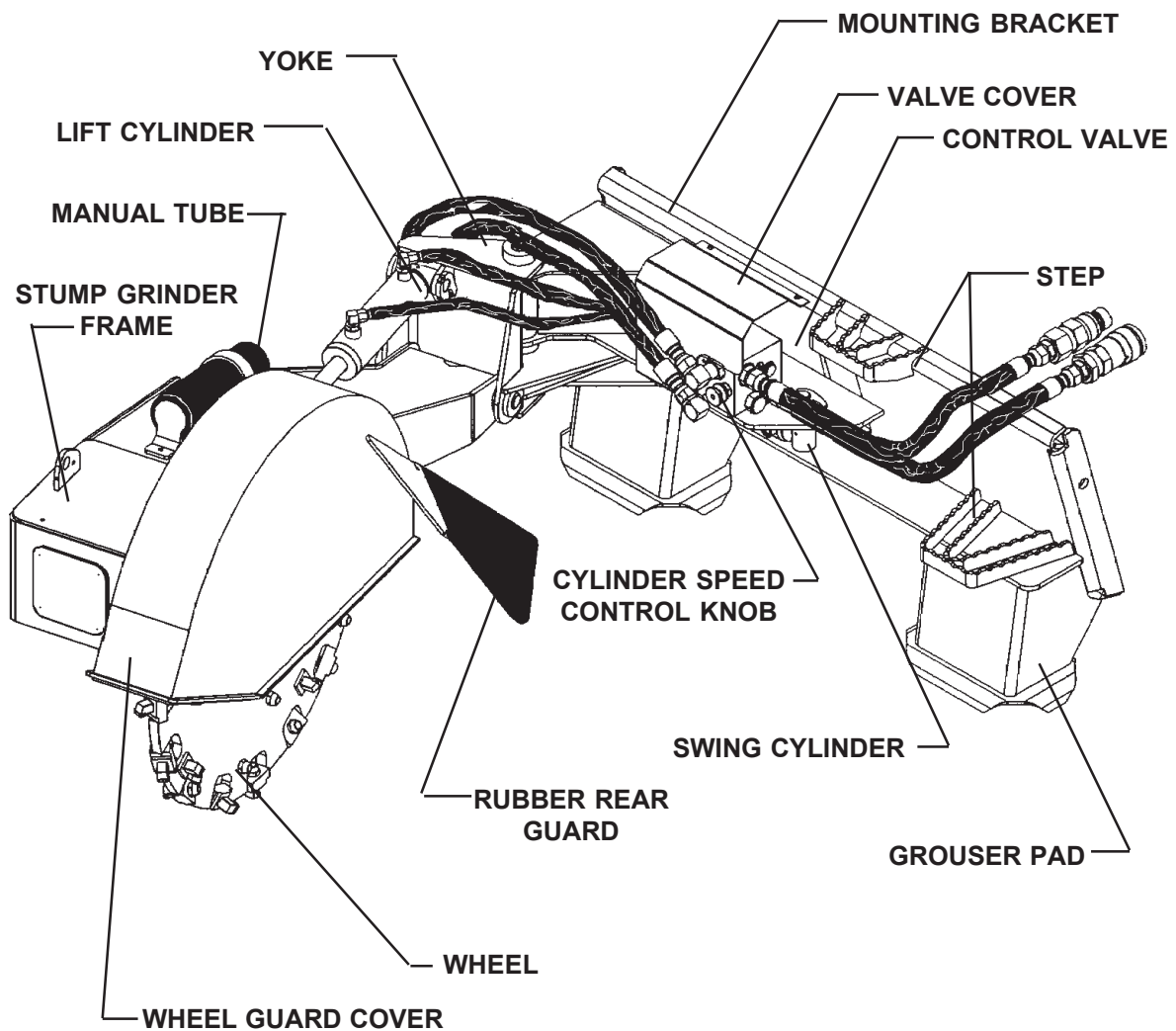

STUMP GRINDER ASSEMBLY

ASSEMBLY #100318

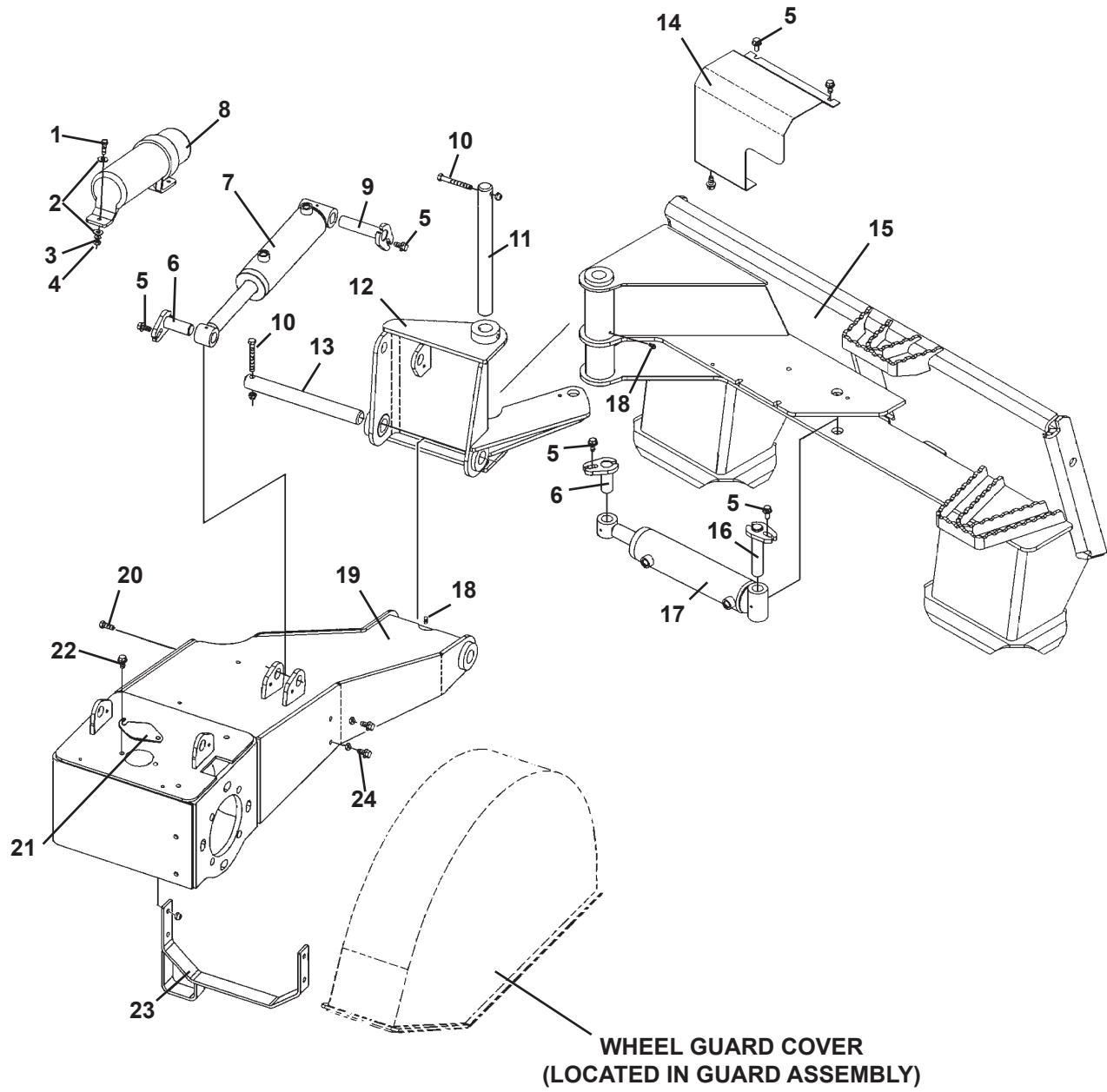

STUMP GRINDER ASSEMBLY

ASSEMBLY #100318

<u>NO</u>	<u>REQ'D</u>	<u>PART NO.</u>	<u>DESCRIPTION</u>
1	2	1022	.31" UNC X 1.00" Hex Capscrew
2	4	1513	.31" Flat Washer
3	2	1502	.31" Lock Washer
4	2	1225	.31" UNC Hex Nut
5	7	1953	.38" UNC X .75" Flange Head Capscrew
6	2	100769	Pin - 1.00" X 2.50"
7	1	101245	Cylinder Assembly - Lift
	-	45617	Replacement Seal Kit
8	1	25453	Manual Tube
9	1	100770	Pin - 1.00" X 4.00"
10	2	1051	.38" UNC X 3.00" Hex Capscrew
	2	1837	.38" UNC Deformed Lock Nut
11	1	100379	Pin - 1.25" X 13.50"
12	1	100322	Yoke
13	1	100378	Pin - 1.25" X 11.38"
14	1	100420	Valve Cover
15	1	100321	Mounting Bracket
16	1	31990	Pin - 1.00" X 4.50"
17	1	100324	Cylinder Assembly - Swing
	-	45617	Replacement Seal Kit
18	2	6616	Grease Fitting
19	1	100323	Stump Grinder Frame
20	2	1043	.38" UNC X 1.00" Hex Capscrew
	2	1837	.38" UNC Deformed Lock Nut
21	1	105762	Access Cover
22	2	1939	.25" UNC X .75" Flangehead Hex Capscrew
23	1	101802	Brace Stand
24	2	1044	.38" UNC X 1.25" Hex Capscrew
	2	1837	.38" UNC Deformed Lock Nut

REAR GUARD ASSEMBLY

ASSEMBLY #101742

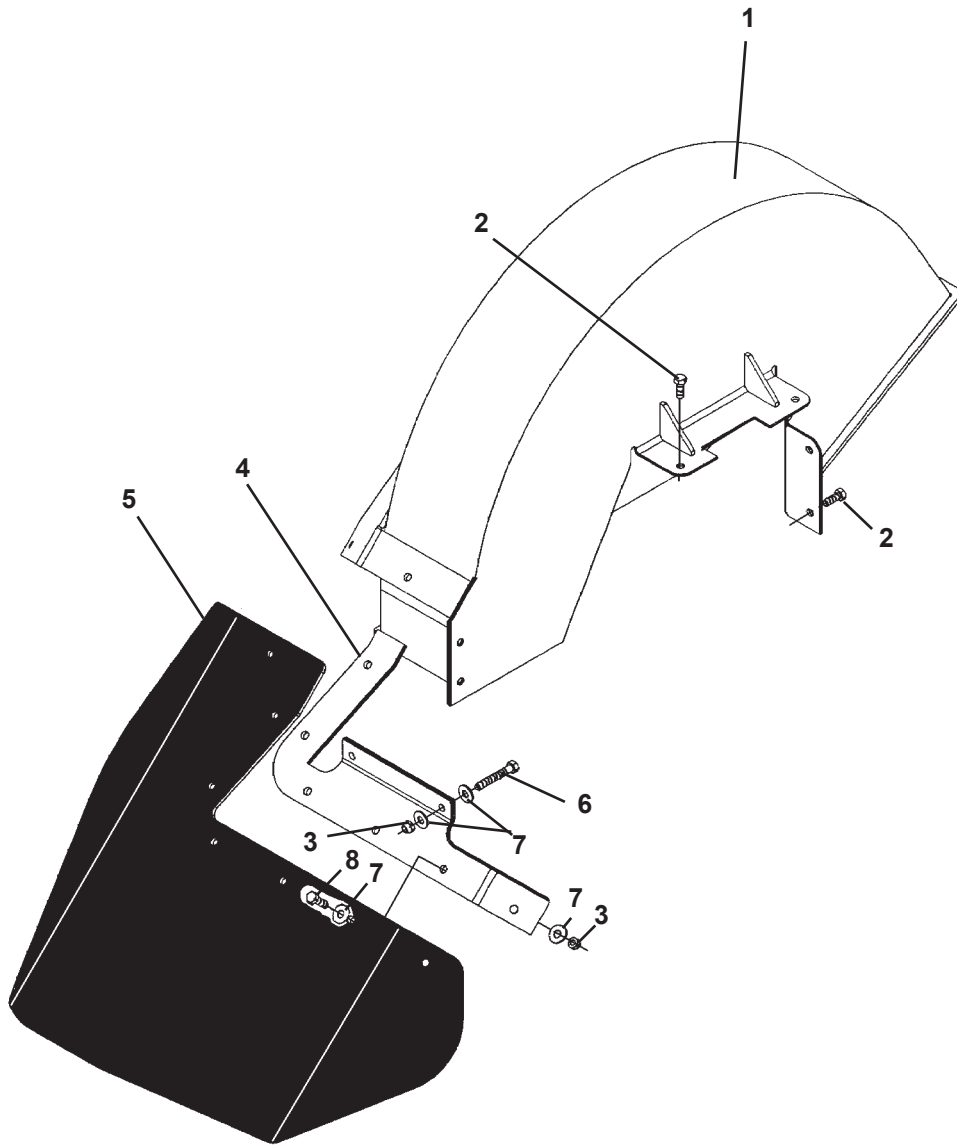

REAR GUARD ASSEMBLY

ASSEMBLY #101742

<u>NO</u>	<u>REQ'D</u>	<u>PART NO.</u>	<u>DESCRIPTION</u>
1	1	102061	Wheel Guard Cover
2	4	1043	.38" UNC X 1.00" Hex Capscrew
3	10	1837	.38" UNC Deformed Oval Lock Nut
4	1	102062	Rear Rubber Guard Bracket
5	1	100802	Rubber Guard
6	2	1049	.38" UNC X 2.50" Hex Capscrew
7	20	1514	.38" Flat Washer
8	8	1044	.38" UNC X 1.25" Hex Capscrew

SQUARE TOOTH WHEEL ASSEMBLY

26" STANDARD FLOW WHEEL ASSEMBLY #101234

30" HIGH FLOW WHEEL ASSEMBLY #100418

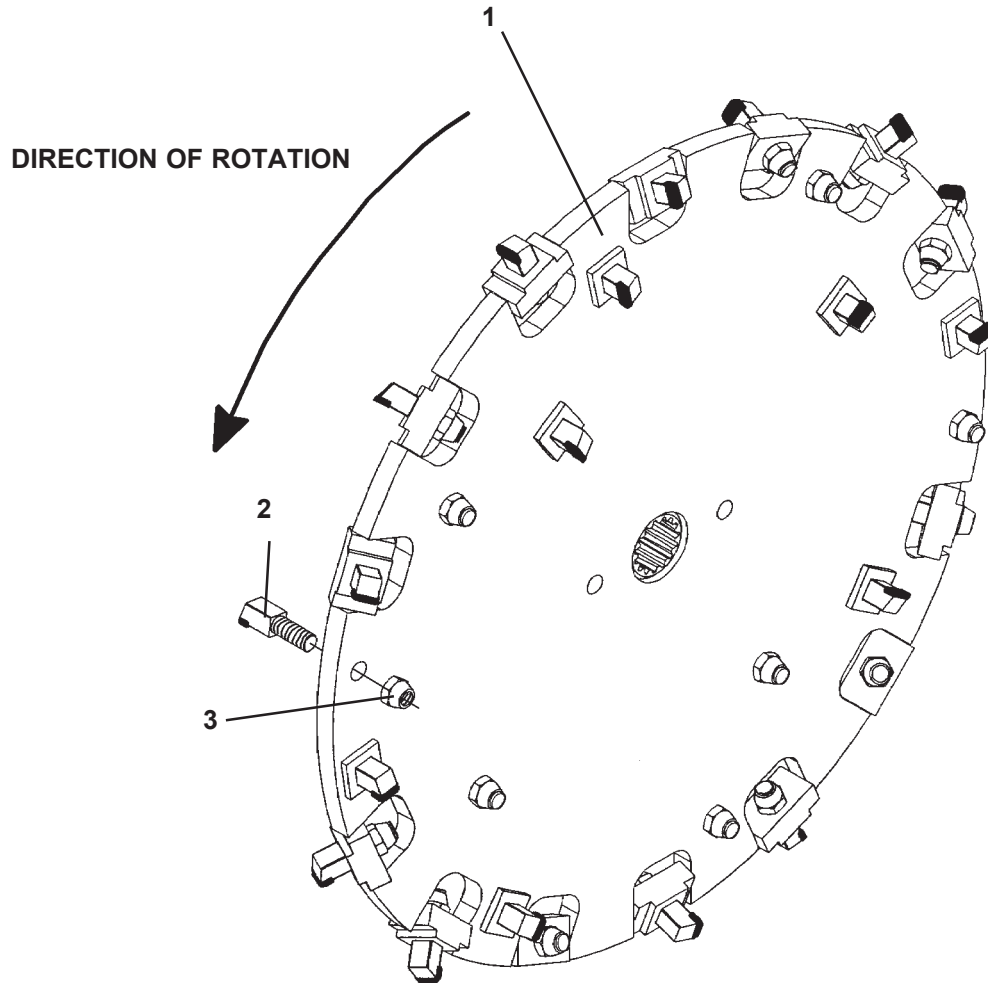

SQUARE TOOTH WHEEL ASSEMBLY

26" STANDARD FLOW WHEEL ASSEMBLY #101234

30" HIGH FLOW WHEEL ASSEMBLY #100418

<u>NO</u>	<u>REQ'D</u>	<u>PART NO.</u>	<u>DESCRIPTION</u>
1	1	101235	26" Wheel - Standard Flow
	1	19911	30" Wheel - High Flow
2	28	19917	Square Tooth - Threaded
3	28	1810	.62" UNF Deformed Lock Nut

REPLACEMENT TOOTH KIT #102075

28	19917	Square Tooth - Threaded
28	1810	.62" UNF Deformed Lock Nut

BOLT-ON TOOTH WHEEL ASSEMBLY

26" STANDARD FLOW WHEEL ASSEMBLY #101243

30" HIGH FLOW WHEEL ASSEMBLY #100416

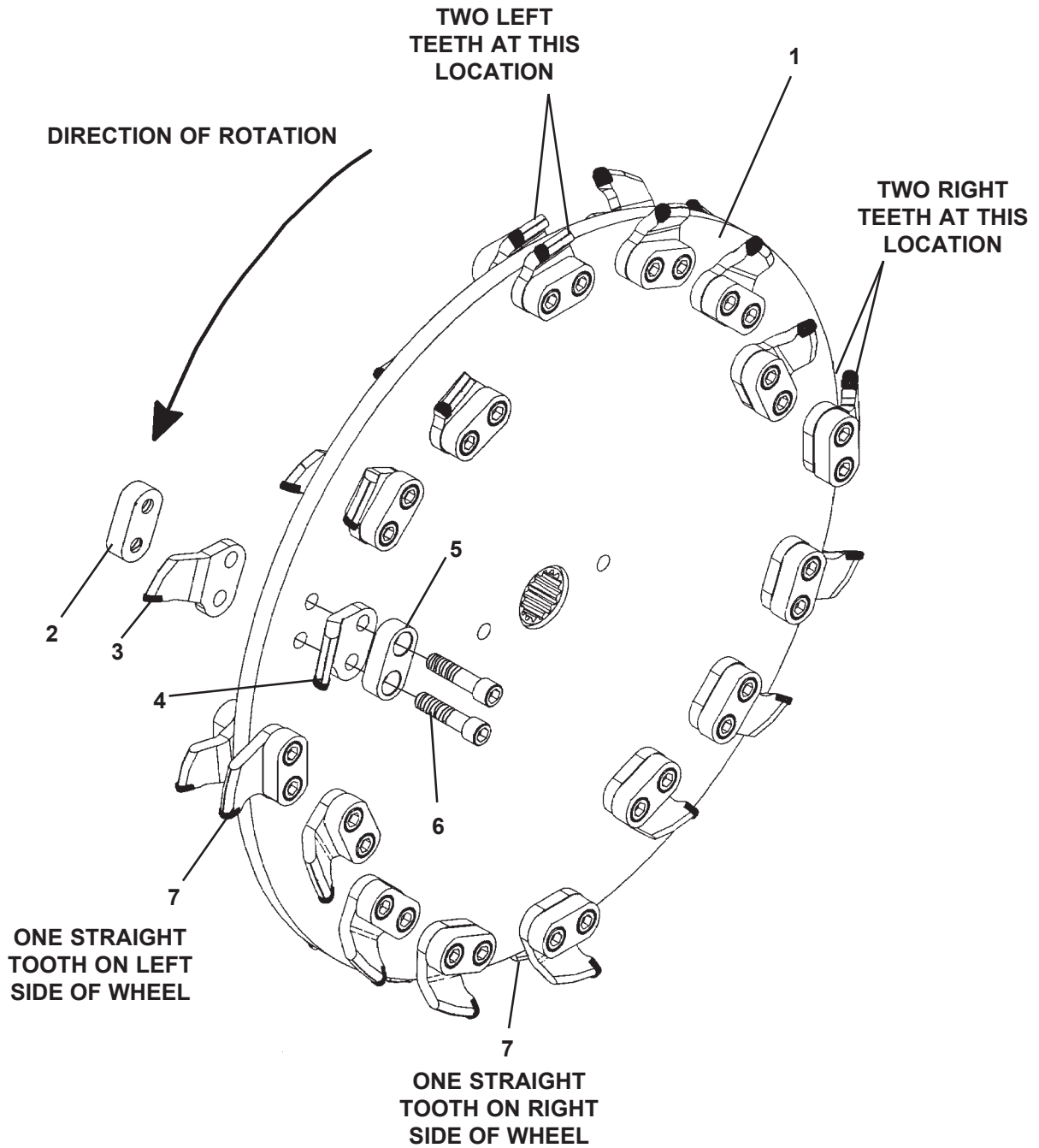

BOLT-ON TOOTH WHEEL ASSEMBLY

26" STANDARD FLOW WHEEL ASSEMBLY #101243

30" HIGH FLOW WHEEL ASSEMBLY #100416

<u>NO</u>	<u>REQ'D</u>	<u>PART NO.</u>	<u>DESCRIPTION</u>
1	1	102147	26" Wheel - Standard Flow
	1	19912	30" Wheel - High Flow
2	16	19959	Tooth Mount - Threaded
3	15	19957	Right Tooth
4	15	19956	Left Tooth
5	16	19960	Tooth Mount - Counterbored
6	32	10091	.62" UNF X 2.50" Sockethead Capscrew
7	2	19958	Straight Tooth

REPLACEMENT TOOTH KIT #102076

	15	19957	Right Tooth
	15	19956	Left Tooth
	2	19958	Straight Tooth

NOTE: When looking at the left side of the wheel as shown every number one position is a special set-up. Twelve o'clock set-up is two left teeth; three o'clock is two right teeth; six o'clock is one left tooth and a straight tooth on the right side of the wheel; and nine o'clock is a right tooth and a straight tooth on the left side of the wheel.

HYDRAULIC VALVE ASSEMBLY

ASSEMBLY #100982

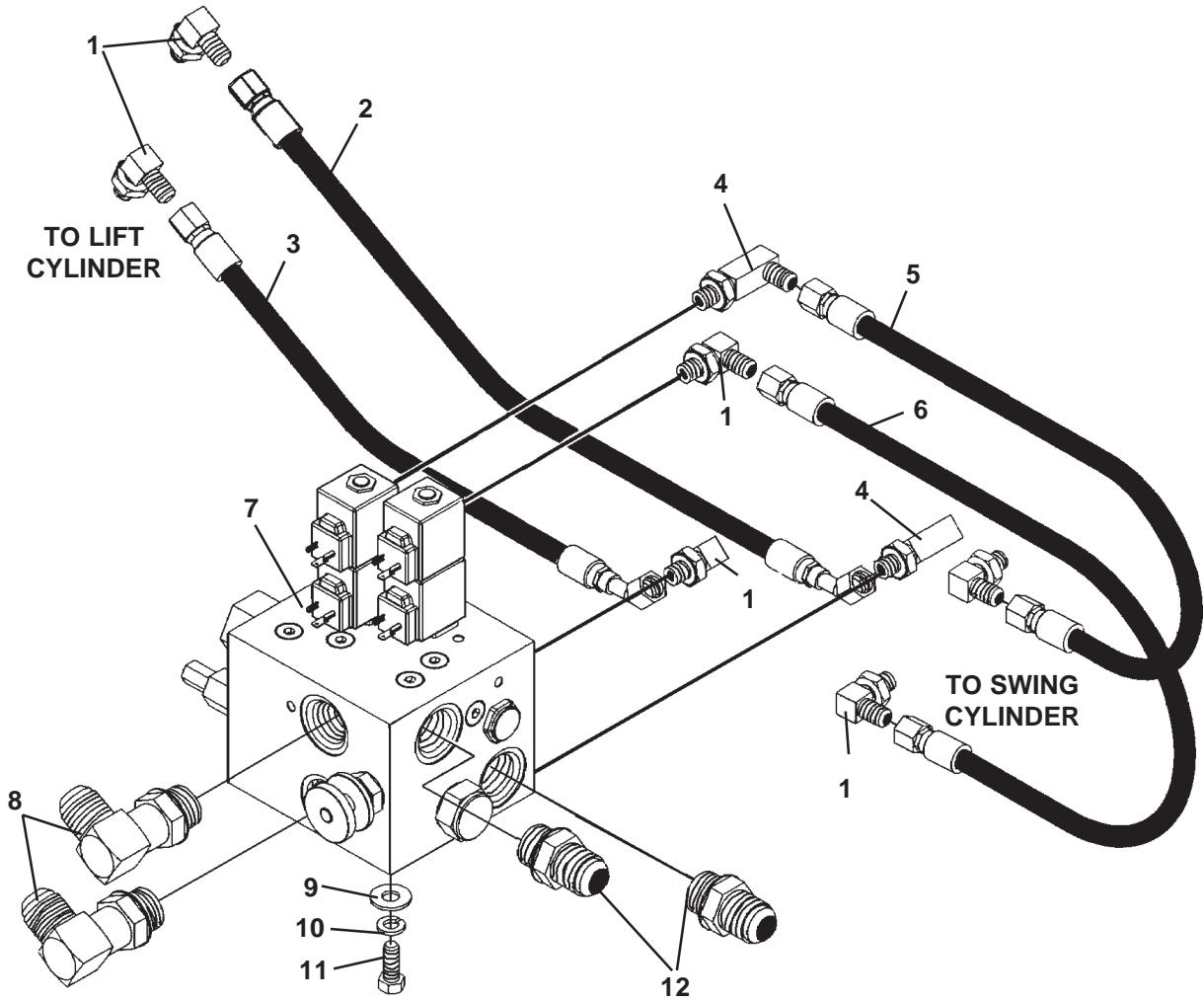

HYDRAULIC VALVE ASSEMBLY

ASSEMBLY #100982

<u>NO</u>	<u>REQ'D</u>	<u>PART NO.</u>	<u>DESCRIPTION</u>
1	6	3434	90° Elbow 6MBo-6MJ
2	1	38196	Hose .25" X 38" 6FJX-6FJX 45°
3	1	38197	Hose .25" X 29" 6FJX-6FJX 45°
4	2	30140	90° Elbow 6MBo-6MJ - XL
5	1	38195	Hose .25" X 19" 6FJX-6FJX
6	1	37345	Hose .25" X 28" 6FJX-6FJX
7	1	101395	Control Valve
8	2	30347	90° Elbow 12MBo-12MJ - L
9	3	1514	.38" Flat Washer
10	3	1503	.38" Lock Washer
11	3	1043	.38" UNC X 1.00" Hex Capscrew
12	2	3419	Straight Connector 12MBo-12MJ

CONTROL VALVE

REPLACEMENT PARTS

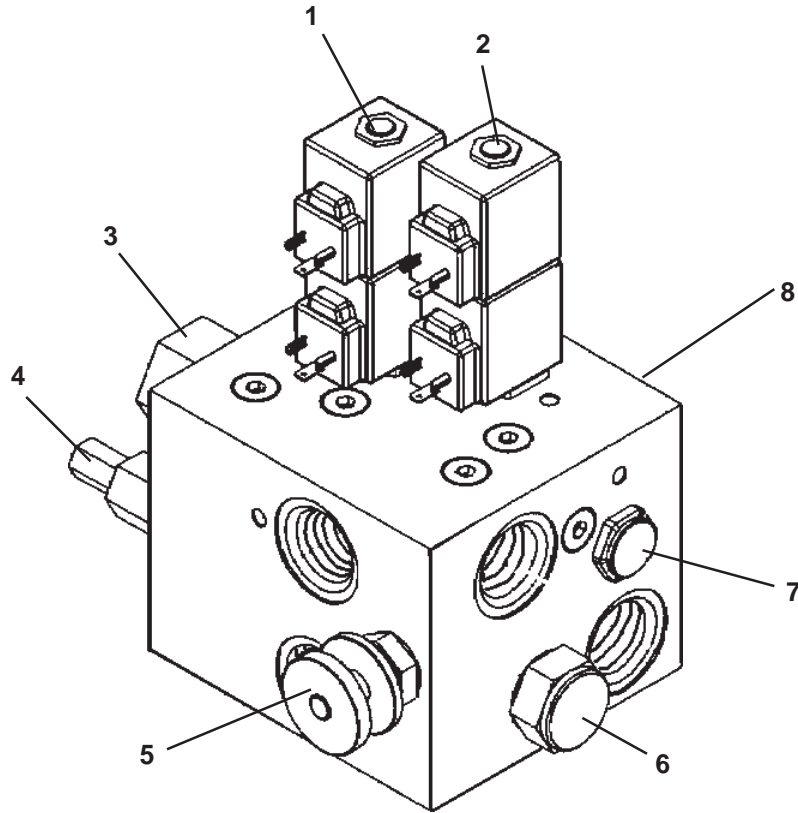

CONTROL VALVE

REPLACEMENT PARTS

<u>NO</u>	<u>REQ'D</u>	<u>PART NO.</u>	<u>DESCRIPTION</u>
1	-	45892	Solenoid Valve Cartridge
	-	45893	Replacement Coil
	-	45894	Spacer
2	-	45888	Solenoid Valve Cartridge
	-	45889	Seal Kit
3	-	45882	Press Comp Cartridge
	-	45883	Seal Kit
4	-	45887	Relief Valve Cartridge
	-	45862	Seal Kit - Relief Valve
5	-	45885	Flow Control Cartridge (Cylinder Speed Control)
	-	45886	Seal Kit - Flow Control
6	-	45863	Check Valve Cartridge
7	-	45890	P.O. Check Valve Cartridge
	-	45891	Seal Kit - P.O. Check Valve
8	-	45884	Check Valve Cartridge
	-	45864	Seal Kit - Check Valve

STANDARD FLOW DRIVE ASSEMBLY

ASSEMBLY #100415

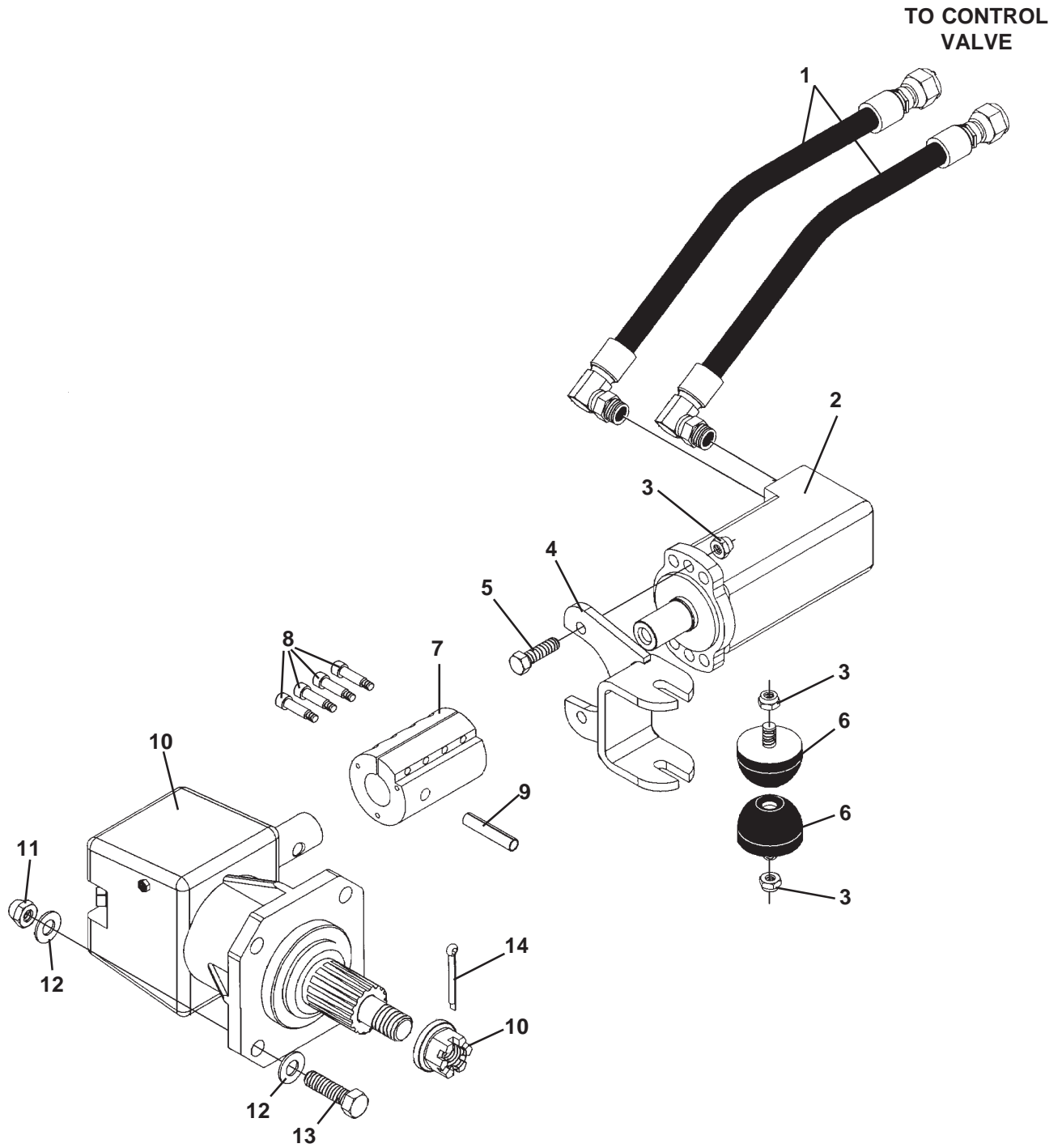

STANDARD FLOW DRIVE ASSEMBLY

ASSEMBLY #100415

<u>NO</u>	<u>REQ'D</u>	<u>PART NO.</u>	<u>DESCRIPTION</u>
1	2	38232	Hose .62" X 52" 10MBo 90° - 12FJX
2	1	17787	Hydraulic Motor
	**	45814	Replacement Seal Kit
3	4	1841	.50" UNC Deformed Lock Nut
4	1	100860	Motor Mount
5	2	1091	.50" UNC X 1.75" Hex Capscrew
6	2	6886	Rubber Bumper
7	1	17808	Coupler
8	4	1799	.38" UNC X 1.50" Sockethead Capscrew
9	1	22277	Roll Pin
10	1	100988	Right Angle Gearbox Assembly
	-	19701	Replacement Castle Nut
	-	19702	Replacement Input Seal
	-	19703	Replacement Output Seal
	-	7781	Replacement Breather Plug
11	4	1839	.62" UNC Deformed Oval Lock Nut
12	8	1627	.62" Hard Flat Washer
13	4	10071	.62" UNC X 2.25" Hex Capscrew - Grade 8
14	1	1613	Cotter Pin

** Field replacement of the internal motor seals voids warranty.

HIGH FLOW DRIVE ASSEMBLY

ASSEMBLY #100417

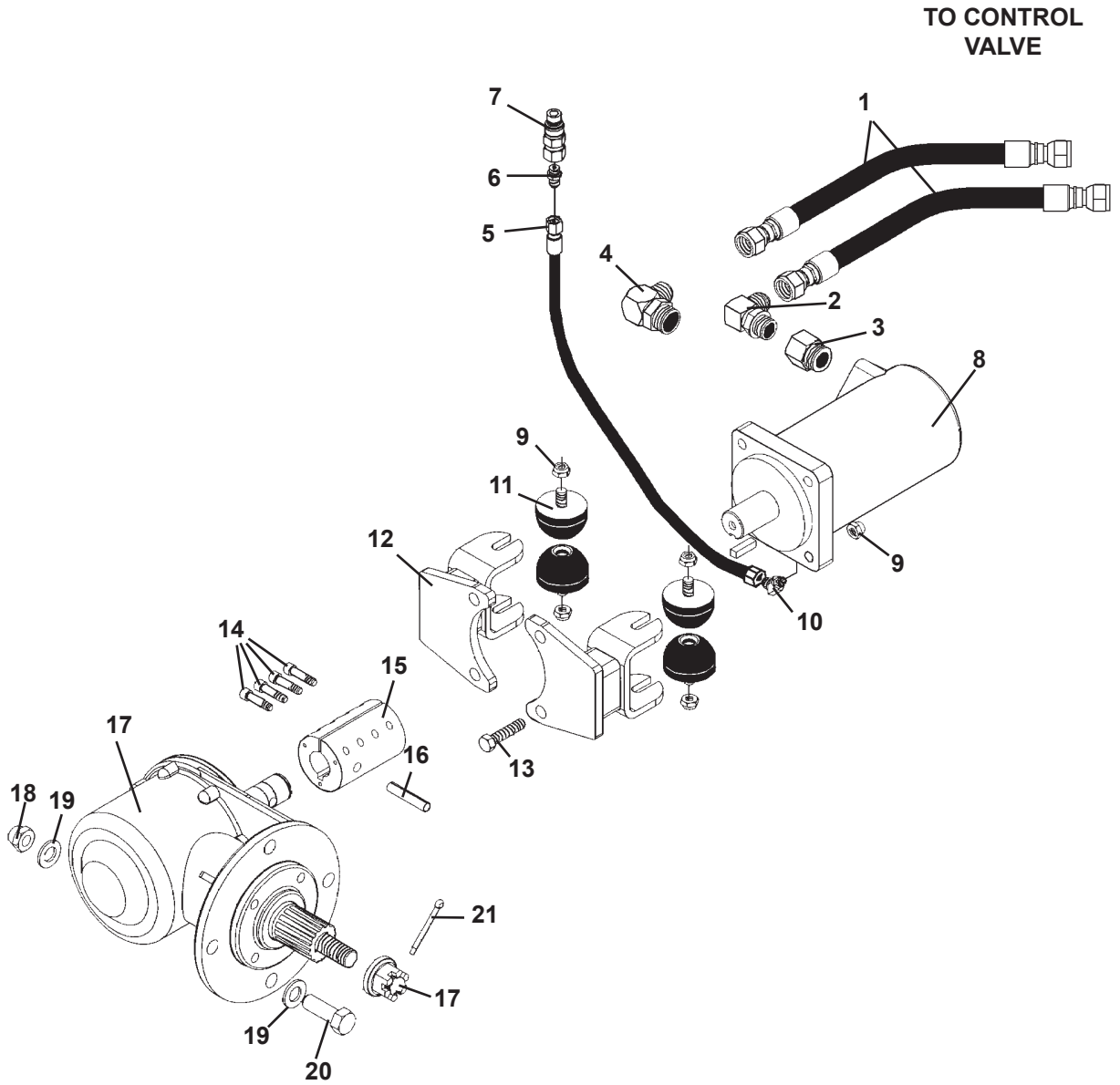

HIGH FLOW DRIVE ASSEMBLY

ASSEMBLY #100417

<u>NO</u>	<u>REQ'D</u>	<u>PART NO.</u>	<u>DESCRIPTION</u>
1	2	38233	Hose .75" X 52" 12FJX - 12FJX
2	1	22600	90° Elbow 12MBo-12MJ
3	1	30292	Straight Connector 16MBo-12FB
4	1	30051	90° Elbow 16MBo-12MJ
5	1	37482	Case Drain Hose .25" X 132" 6FJX-6FJX
	1	38234	Case Drain Hose .25" X 148" 6FJX-6FJX (Not Included in Drive Assembly)
6	1	3269	Straight Adapter 8MBo-6MJ (Not Included in Drive Assembly)
7	1	84923	Male Coupler (Not Included in Drive Assembly)
8	1	101793	Hydraulic Motor
	**	45898	Replacement Shaft Seal Kit
	**	45899	Replacement Rear Seal Kit
9	8	1841	.50" UNC Deformed Lock Nut
10	1	30388	45° Elbow 4MBo-6MJ
11	4	6886	Rubber Bumper
12	2	101785	Motor Mount
13	4	10086	.50" UNC X 2.25" Capscrew
14	4	1799	.38" UNC X 1.50" Sockethead Capscrew
15	1	100917	Coupler
16	1	22277	Roll Pin
17	1	101509	Right Angle Gearbox Assembly
	-	19701	Replacement Castle Nut
	-	102011	Replacement Input Seal
	-	102010	Replacement Output Seal
	-	7781	Replacement Breather Plug
18	4	1936	.75" UNC Deformed Oval Lock Nut
19	8	1649	.75" Hard Flat Washer
20	4	1140	.75" UNC X 2.25" Hex Capscrew
21	1	1613	Cotter Pin

** Field replacement of the internal motor seals voids warranty.

STANDARD FLOW HOSE SET

POWER AND RETURN CIRCUIT

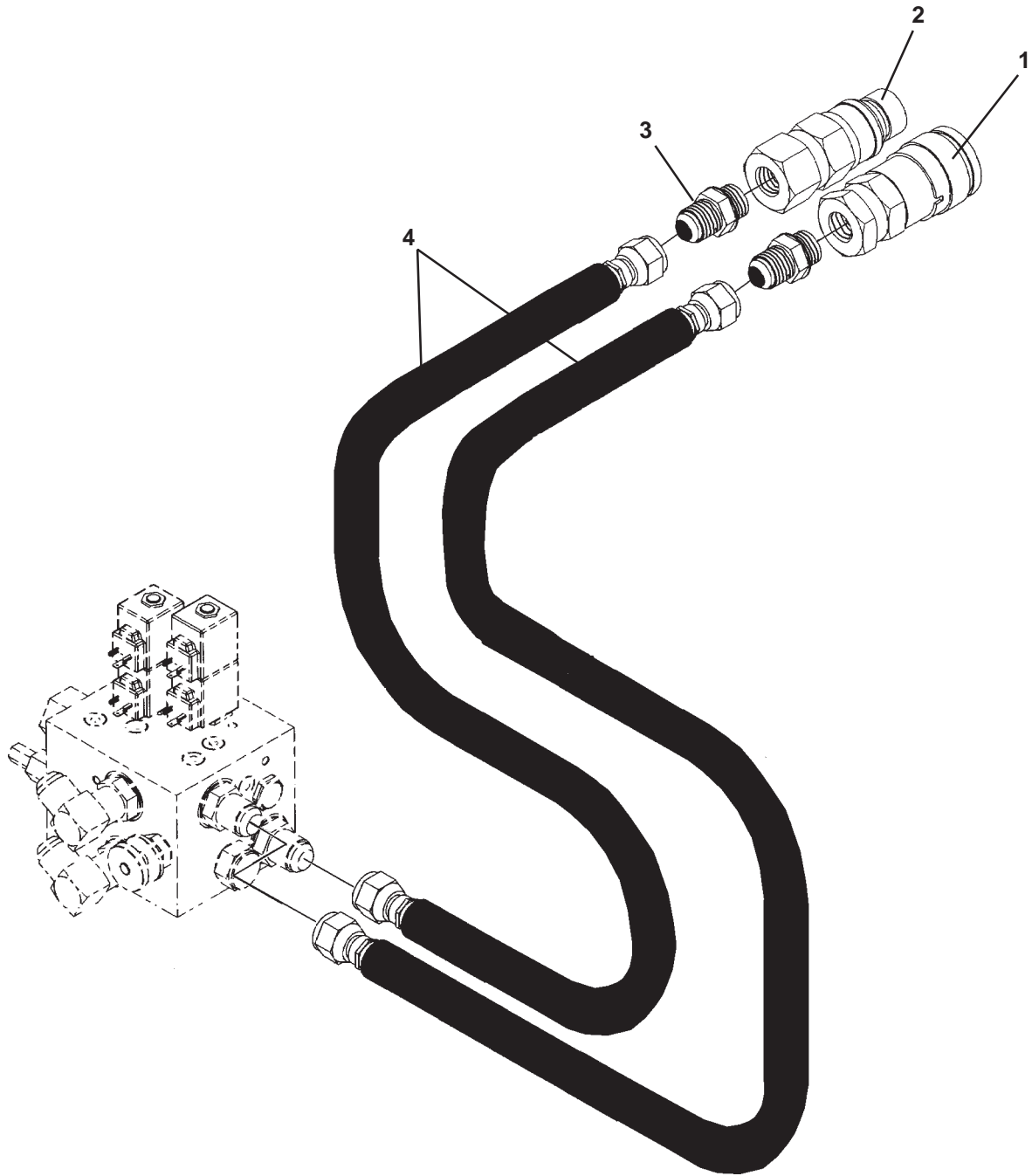

STANDARD FLOW HOSE SET

POWER AND RETURN CIRCUIT

HOSE KIT #100983

<u>NO</u>	<u>REQ'D</u>	<u>PART NO.</u>	<u>DESCRIPTION</u>
1	1	22518	Female Coupler
2	1	19632	Male Coupler
3	2	3419	Straight Connector 12MBo-12MJ
4	2	38235	Hose .62" X 72" 12FJX-12FJX

HOSE KIT #100984

<u>NO</u>	<u>REQ'D</u>	<u>PART NO.</u>	<u>DESCRIPTION</u>
1	1	22518	Female Coupler
2	1	19632	Male Coupler
3	2	3419	Straight Connector 12MBo-12MJ
4	2	38236	Hose .62" X 88" 12FJX-12FJX

HIGH FLOW HOSE SET

POWER AND RETURN CIRCUIT

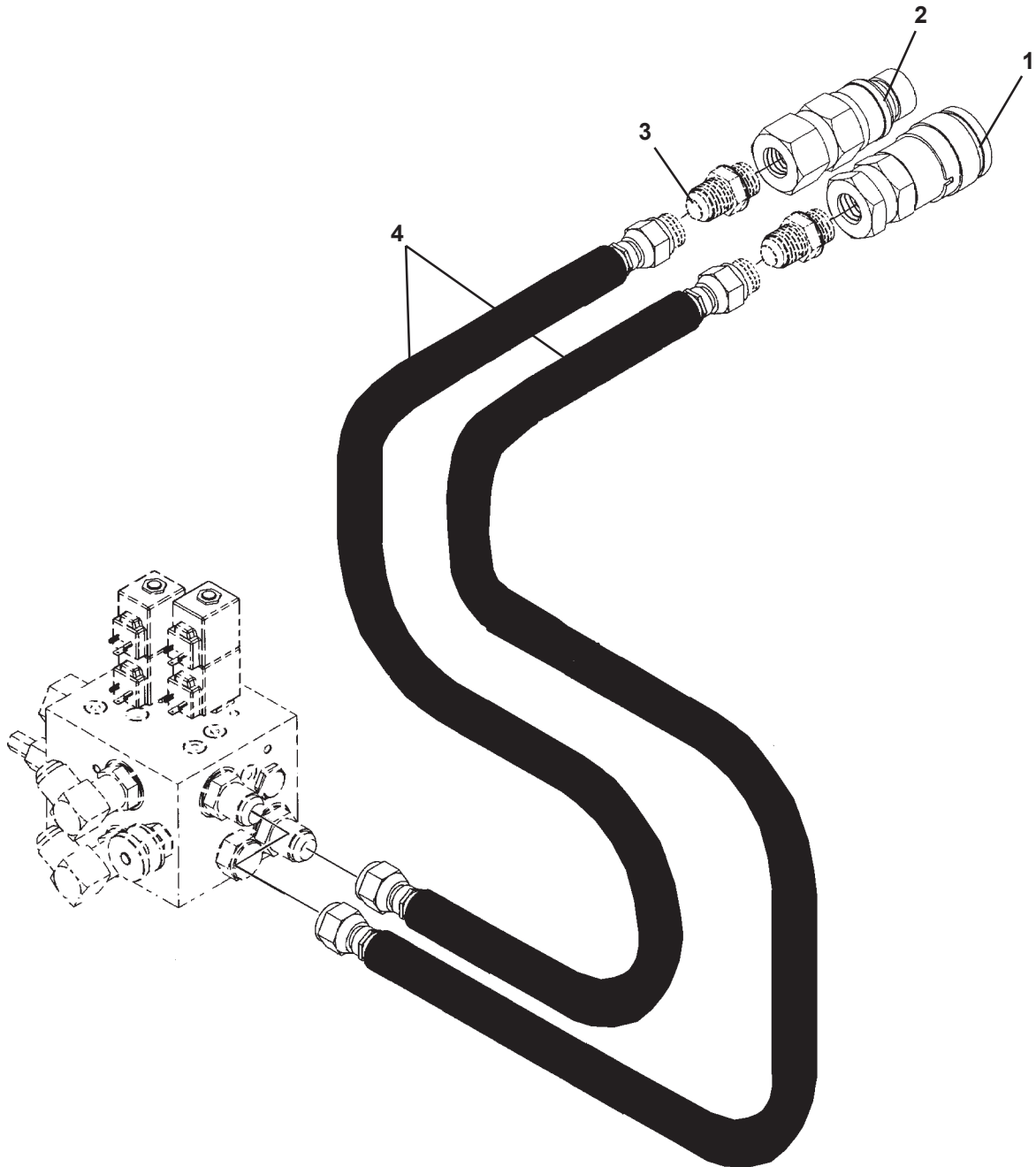

HIGH FLOW HOSE SET

POWER AND RETURN CIRCUIT

HOSE KIT #101754

<u>NO</u>	<u>REQ'D</u>	<u>PART NO.</u>	<u>DESCRIPTION</u>
1	1	84921	Female Coupler .62"-12FBo-FF
2	1	19636	Male Coupler 62"-12FBo-FF
3	2	3419	Straight Connector 12MBo-12MJ
4	2	35920	Hose .75" X 73" 12FJX-12FJX

* Case drain hoses and fittings included in this kit are shown on the High Flow Drive Assembly pages.

HOSE KIT #101755

<u>NO</u>	<u>REQ'D</u>	<u>PART NO.</u>	<u>DESCRIPTION</u>
1	1	84921	Female Coupler 62"-12FBo-FF
2	1	19636	Male Coupler 62"-12FBo-FF
3	-	----	NOT USED WITH LONGER HOSE #37060
4	2	37060	Hose .75" X 88" 12MBo-12FJX

* Case drain hoses and fittings included in this kit are shown on the High Flow Drive Assembly pages.

HOSE KIT #102073

<u>NO</u>	<u>REQ'D</u>	<u>PART NO.</u>	<u>DESCRIPTION</u>
1	1	22520	Female Coupler .75"-12FBo-FF
2	1	19638	Male Coupler 75"-12FBo-FF
3	2	3419	Straight Connector 12MBo-12MJ
4	2	35920	Hose .75" X 73" 12FJX-12FJX

* Case drain hoses and fittings included in this kit are shown on the High Flow Drive Assembly pages.

HOSE KIT #102074

<u>NO</u>	<u>REQ'D</u>	<u>PART NO.</u>	<u>DESCRIPTION</u>
1	1	84921	Female Coupler 62"-12FBo-FF
2	1	19636	Male Coupler 62"-12FBo-FF
3	-	----	NOT USED WITH LONGER HOSE #37060
4	2	37060	Hose .75" X 88" 12MBo-12FJX

* Case drain hoses and fittings included in this kit are shown on the High Flow Drive Assembly pages.

CYLINDER ASSEMBLY

ASSEMBLY #100324

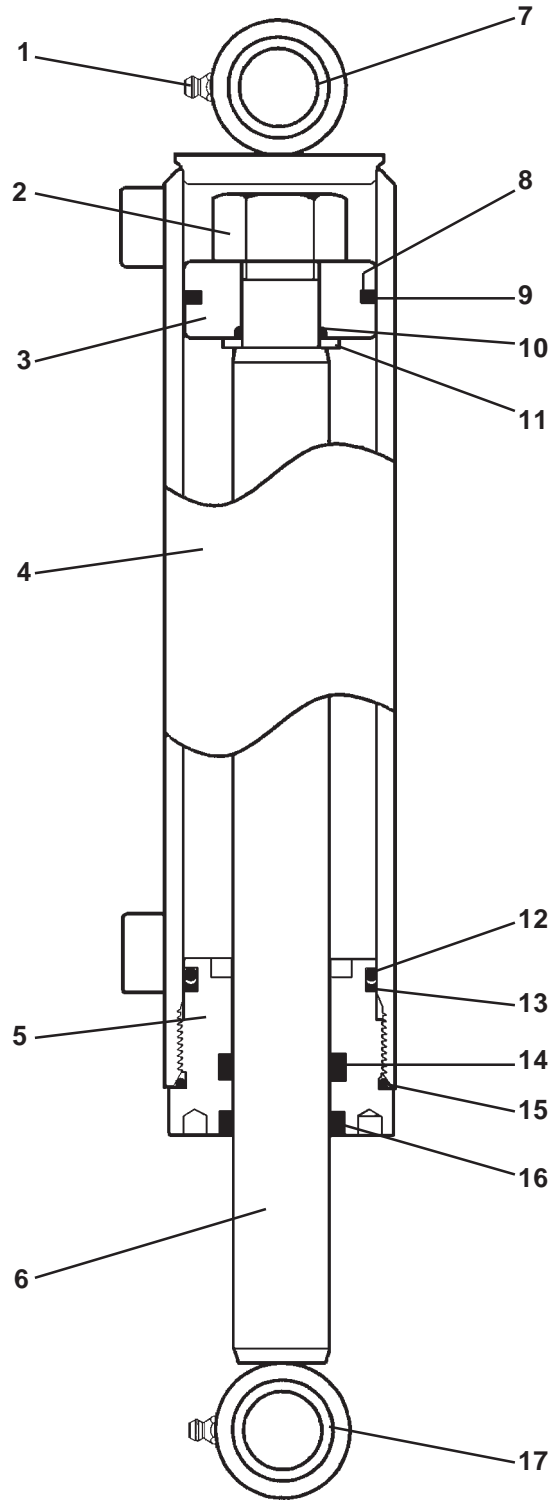

CYLINDER ASSEMBLY

ASSEMBLY #100324

<u>NO</u>	<u>REQ'D</u>	<u>PART NO.</u>	<u>DESCRIPTION</u>
1	2	6616	Grease Fitting
2	1	1483	Hex Nut
3	1	50252	Piston
4	1	88926	Cylinder Tube
5	1	77458	Cylinder Gland
6	1	100325	Cylinder Rod
7	2	88919	Bushing
8	1	4644*	Piston Ring
9	1	4645*	O'Ring
10	1	4641*	O'Ring
11	1	5421	Washer
12	1	4509*	O'Ring
13	1	4510*	Back-Up Washer
14	1	45219*	Poly-Pak Seal
15	1	45250*	O'Ring
16	1	45389*	Rod Wiper
17	1	88918	Bushing

NOTE: Seal Kit #45617 includes all parts marked with an asterisk (*). Parts are not sold separately.

CYLINDER ASSEMBLY

ASSEMBLY #101245

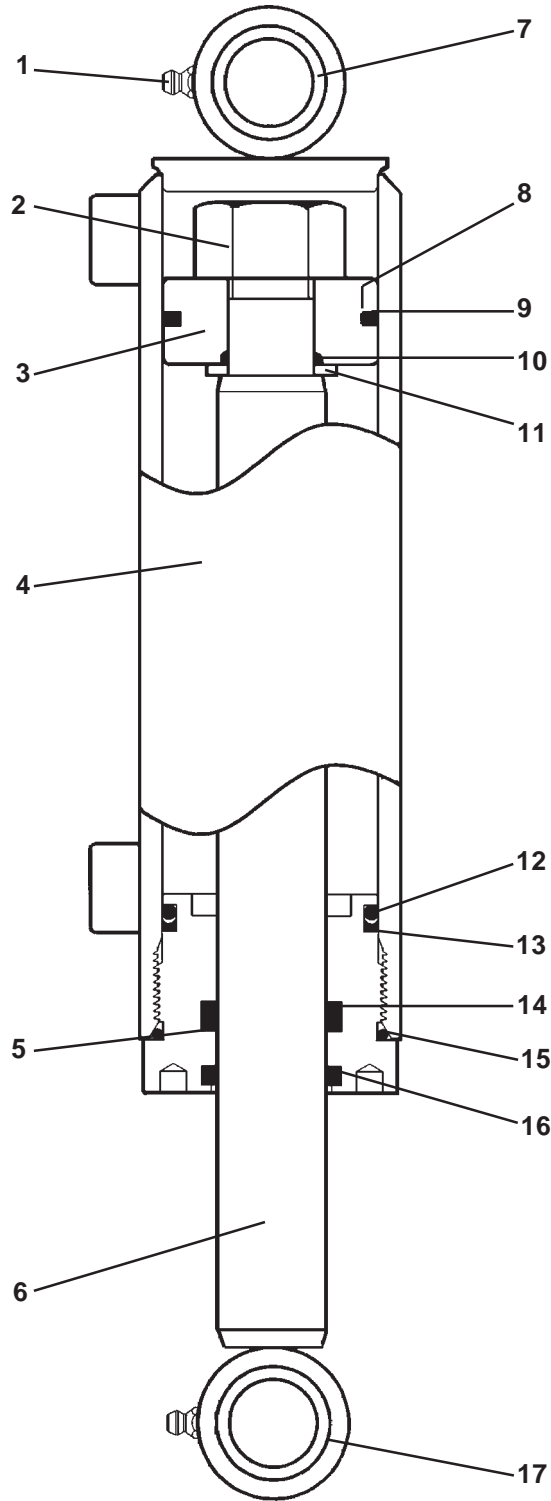

CYLINDER ASSEMBLY

ASSEMBLY #101245

<u>NO</u>	<u>REQ'D</u>	<u>PART NO.</u>	<u>DESCRIPTION</u>
1	2	6616	Grease Fitting
2	1	1483	Hex Nut
3	1	50252	Piston
4	1	101246	Cylinder Tube
5	1	77458	Cylinder Gland
6	1	101247	Cylinder Rod
7	2	88919	Bushing
8	1	4644*	Piston Ring
9	1	4645*	O'Ring
10	1	4641*	O'Ring
11	1	5421	Washer
12	1	4509*	O'Ring
13	1	4510*	Back-Up Washer
14	1	45219*	Poly-Pak Seal
15	1	45250*	O'Ring
16	1	45389*	Rod Wiper
17	1	88918	Bushing

NOTE: Seal Kit #45617 includes all parts marked with an asterisk (*). Parts are not sold separately.

CONTROL BOX ASSEMBLY

BRADCO ELECTRICAL CONTROL HANDLE ASSEMBLY #104367
(DIRECT CONNECT TO CONTROL VALVE)

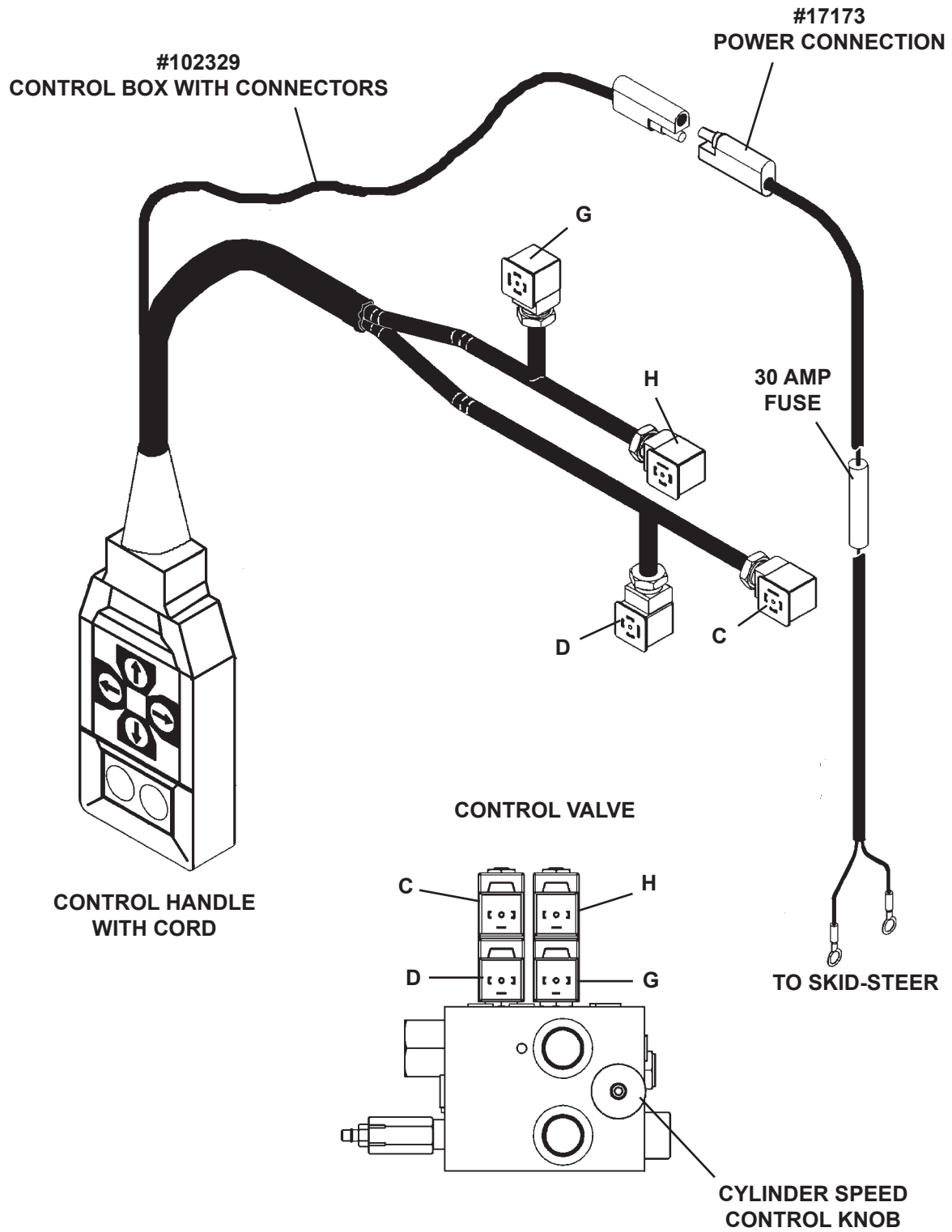

CONTROL BOX ASSEMBLY

OPTIONAL ELELCTRICAL CONTROL BOX ASSEMBLY #104368
(USE WITH WIRING HARNESS #101096)

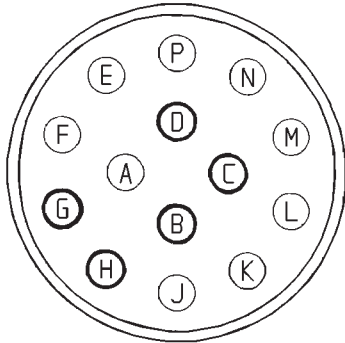

DEUTSCH CONNECTOR PIN DETAIL

- B = BLACK (GROUND)
- C = DARK GREEN (SWING - LEFT)
- D = BROWN (SWING - RIGHT)
- G = ORANGE (LIFT - DOWN)
- H = YELLOW (LIFT - UP)

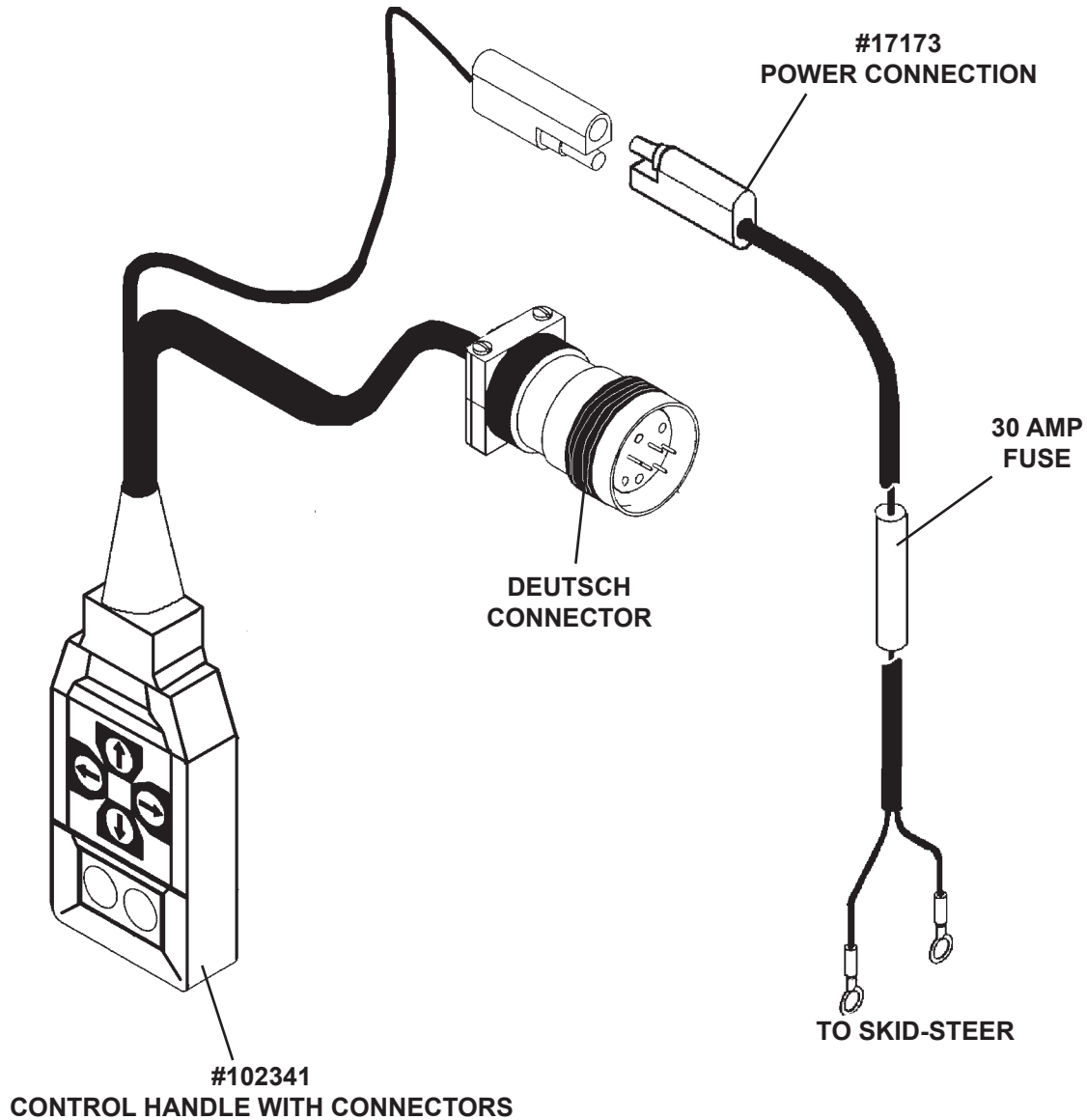

ELECTRICAL HARNESS

WIRING HARNESS #101096

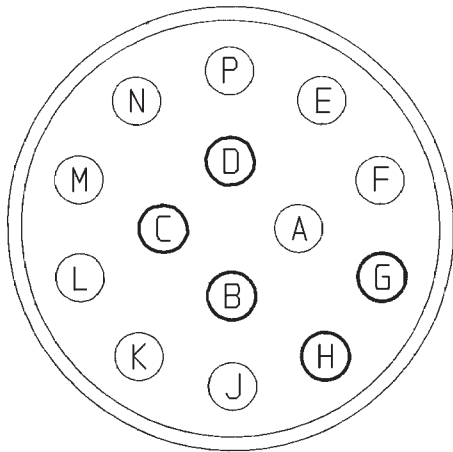

DEUTSCH CONNECTOR PIN DETAIL

- B = BLACK (GROUND)
- C = DARK GREEN (SWING - LEFT)
- D = BROWN (SWING - RIGHT)
- G = RED (LIFT - DOWN)
- H = YELLOW (LIFT - UP)

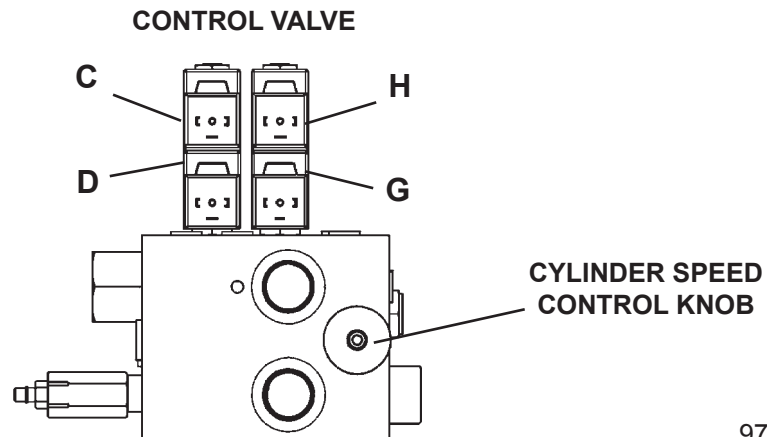
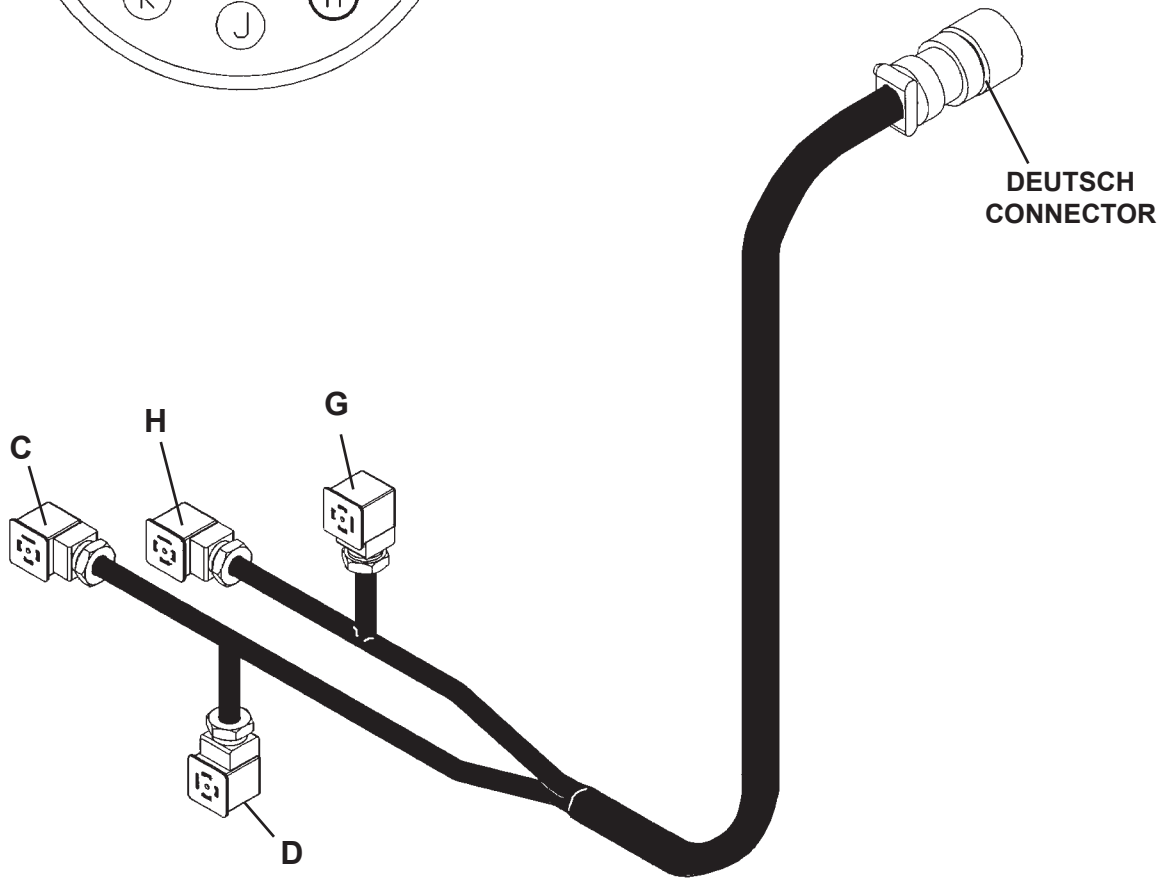

ELECTRICAL SCHEMATIC

WIRING HARNESS #108035

DEUTSCH CONNECTOR PIN DETAIL

B = RED (LIFT - DOWN)

C = BROWN (SWING - RIGHT)

D = DARK GREEN (SWING - LEFT)

F = BLACK (GROUND)

G = YELLOW (LIFT - UP)

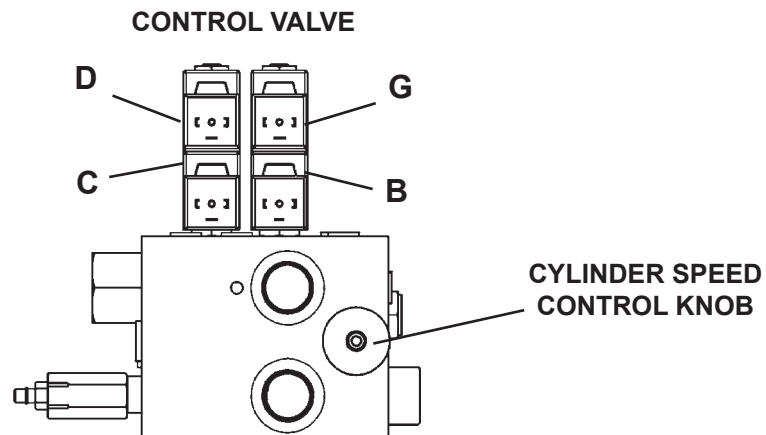
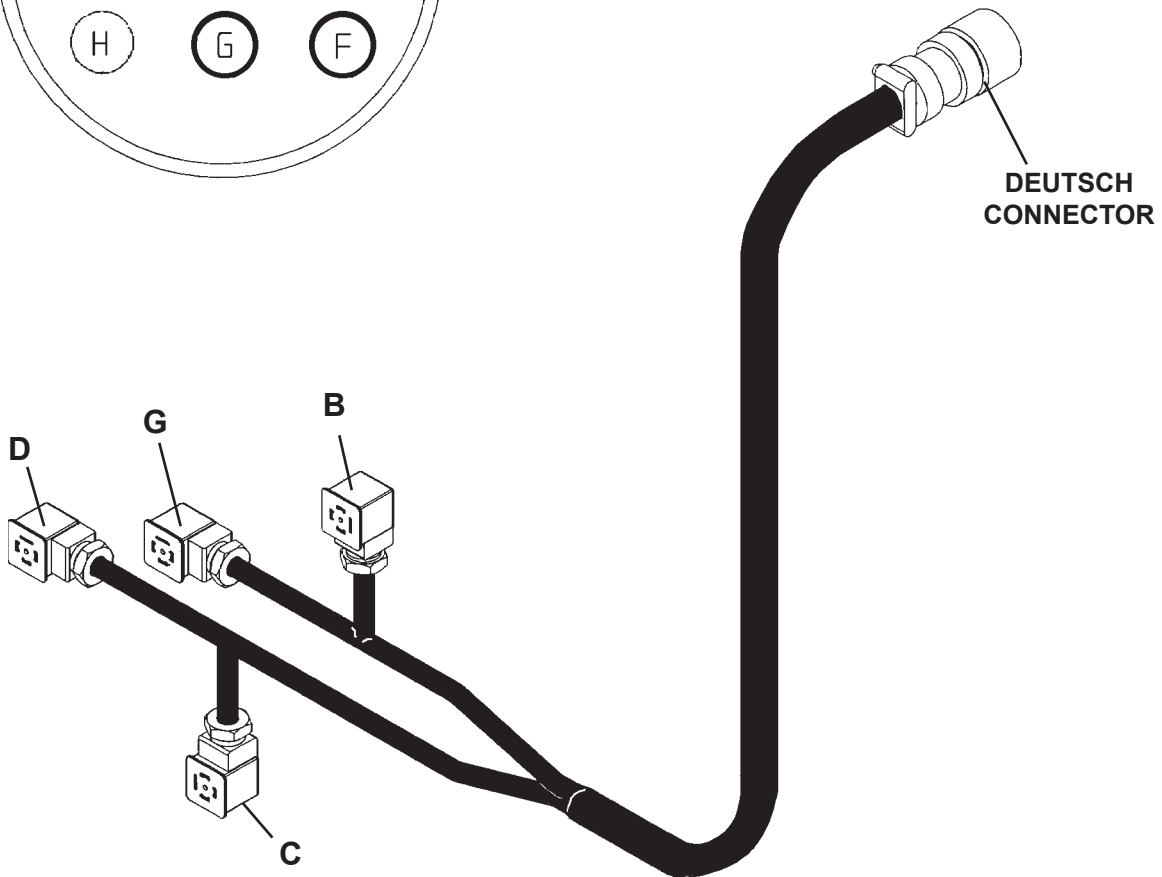
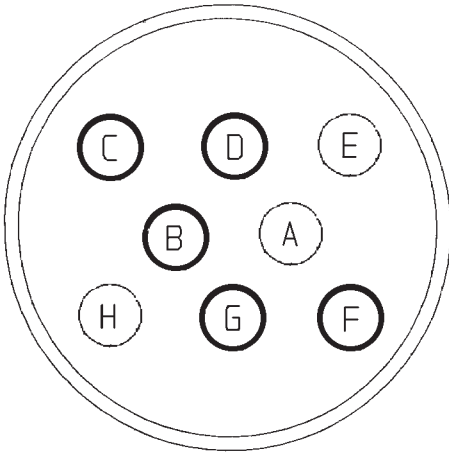

ELECTRICAL SCHEMATIC

WIRING HARNESS #108036

DEUTSCH CONNECTOR PIN DETAIL

A = BLACK (GROUND)

C = DARK GREEN (SWING - LEFT)

D = BROWN (SWING - RIGHT)

E = YELLOW (LIFT - UP)

G = RED (LIFT - DOWN)

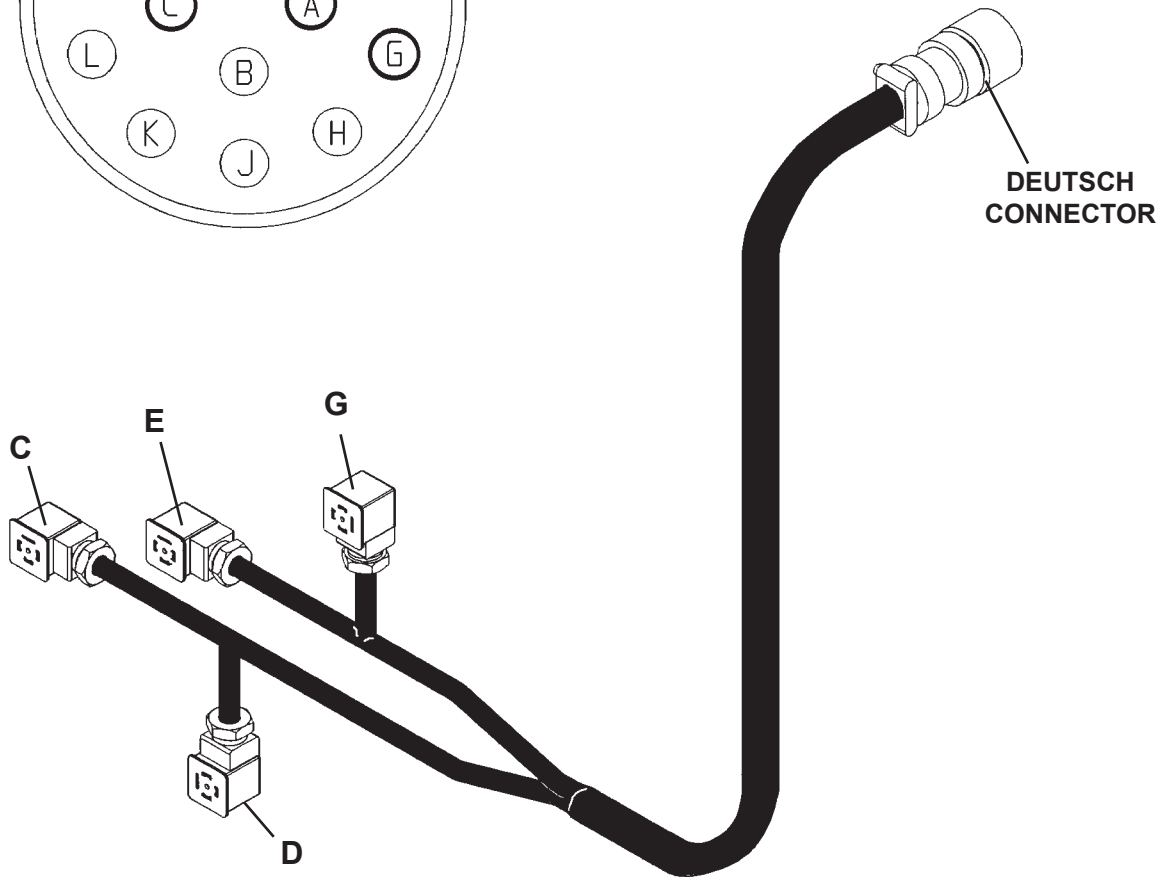
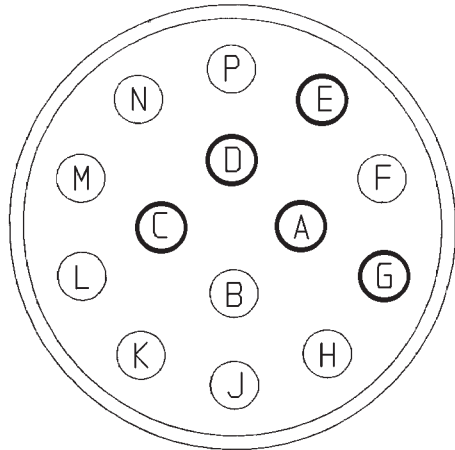

CONTROL VALVE

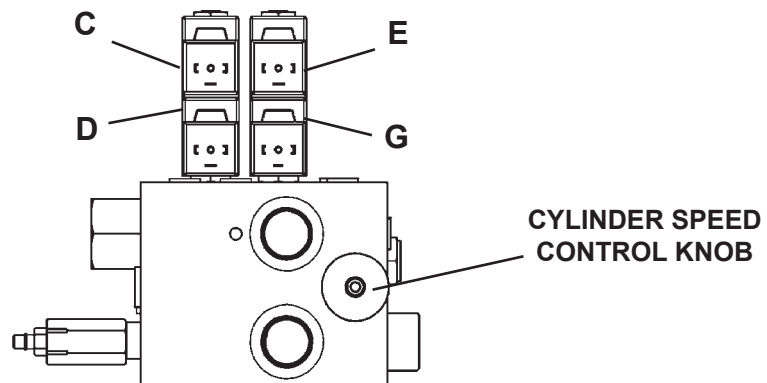

INSTALLATION INSTRUCTIONS

GENERAL INFORMATION

The following instructions will help you to mount your stump grinder onto your skid-steer loader. The stump grinder uses the quick-attach system for ease of installation. Therefore, if you know how to attach your bucket, attaching the stump grinder should prove no problem.

Remember to read all safety warning, decals and operations instructions before operating the attachment. If there is any portion of this manual that you do not understand, contact your dealer.

WARNING! OPERATING THE STANDARD FLOW STUMP GRINDER ON A HIGH FLOW HYDRAULIC SYSTEM MAY CAUSE SEVERE INJURY OR DEATH TO THE OPERATOR OR BYSTANDERS DUE TO THE INCREASED RPM.



INSTALLATION INSTRUCTIONS

1. Remove any shipping banding from around the stump grinder and skid.
2. Remove any attachment from the front of the loader.
3. Following all standard safety practices and the instructions for installing an attachment on your skid-steer operator's manual, install the stump grinder onto your skid-steer.

NOTE: IT IS IMPORTANT TO MAKE SURE THE LOCKING MECHANISM ON YOUR QUICK ATTACH IS ENGAGED, THEREFORE LOCKING THE ATTACHMENT ONTO THE SKID-STEER.

4. Lower the unit to the ground and remove the key.
5. If the rear guard assembly was not installed at the factory, install it now using the hardware provided. (See Section E for hardware locations.)
6. Relieve any pressure from the auxiliary hydraulic system and after making sure that there is not any foreign matter on the hydraulic couplers, connect the couplers to the auxiliary hydraulic system of your skid-steer loader.
7. If installing the high flow stump grinder, connect the case drain coupler to the case drain on your skid-steer loader. Route the hoses in such a fashion as to avoid pinching or chafing.

CAUTION! BE SURE CASE DRAIN COUPLER IS COMPLETELY ENGAGED. IMMEDIATE HYDRAULIC MOTOR SEAL FAILURE WILL OCCUR IF CASE DRAIN IS NOT SUCCESSFULLY CONNECTED.



INSTALLATION INSTRUCTIONS

8. Route the electrical control handle to the operator's station taking care to avoid pinching of the electrical wire harness. NOTE: If your skid-steer is equipped with a multi-function control handle, connect the electrical wire harness from the stump grinder to the auxiliary electrical connector on the front of the skid-steer.
9. Following all standard safety practices, start the skid-steer and run all cylinders through their full cycle to purge any air from the system. Check that all controls function according to the operating control decal. Your stump grinder is now installed and ready for operation.

DISCONNECT INSTRUCTIONS

1. With the stump grinder extended halfway out, lower the unit onto the grouser pads on the mounting bracket and the brace stand. NOTE: Extending the unit will help prevent it from tipping forward when disconnected.
2. Following Safety Shut Down Procedures; stop the engine and set the parking brake, relieve any pressure in the hydraulic lines.
3. Disconnect the power and return hoses from the auxiliary hydraulics. (Disconnect case drain coupler from the case drain if using the high flow stump grinder.)
4. Disconnect the electrical wire harness from the auxiliary electrical connector (if so equipped).
5. Following all standard safety practices and the instructions for disconnecting an attachment in your skid-steer operator's manual, disconnect the stump grinder from your skid-steer.
6. Connect the hydraulic couplers on the attachment together to prevent contaminants from entering the hydraulic system.

OPERATING INSTRUCTIONS

STUMP GRINDER

GENERAL INFORMATION

The BRADCO stump grinder is perfect for landscaping and maintaining parks and municipalities. The easy maneuverability of the skid-steer allows access to areas often inaccessible and it is easily moved from site to site. The offset design offers excellent visibility and can be used in tight spaces around buildings and homes.

The quick attach mounting plate allows for easy hook-up and disconnect. Therefore the time required to remove the stump grinder from the skid-steer and attach a bucket for clean up is greatly reduced from conventional stump grinders. Due to this arrangement, thorough knowledge of the skid-steer controls is necessary for machine operation. Read your skid-steer operator's manual for information regarding skid-steer operation before attempting to use the stump grinder.

Follow all installation instructions (Section F) for the proper installation of the unit onto your skid-steer before operating.

STUMP GRINDING OPERATION

WARNING! CHECK THE WORK AREA AND KNOW WHERE ALL UTILITY LINES ARE BEFORE OPERATING THE STUMP GRINDER.



OPERATE THE STUMP GRINDER FROM INSIDE THE OPERATOR'S STATION OF YOUR SKID-STEER LOADER ONLY.

1. Swing the stump grinder all the way to the right, align the grinder with the stump in such a fashion that the skid-steer is as level as possible from left to right.
2. Position the cutting wheel to the right of the stump. Lower the frame so the grouser pads are resting on the ground. This will assist in stabilizing the unit for even cutting and reduce the inadvertent movement of the skid-steer.

NOTE: It is recommended that the pivot pin, attaching the mounting bracket to the yoke, be perpendicular to the ground or as close to perpendicular as possible for the best performance of the unit.

NOTE: Be sure the cutting wheel is not contacting the ground.

3. Activate the auxiliary hydraulics to the stump grinder and increase the engine to full RPM.
4. Adjust the cutting wheel to cut approximately 1 to 1-1/2" of stump.

OPERATING INSTRUCTIONS

STUMP GRINDER

NOTE: The cutting depth of each pass will be determined by the type of tree. Certain varieties of trees will allow for a deeper cut than trees containing a lot of sap.

5. Swing the cutting wheel to the left across the top of the stump on the edge closest to the skid-steer. Lower the grinder another 1 to 1-1/2" and swing the cutting wheel back across the stump to the right.
6. Continue cutting in this manner. If the wheel stalls, reduce the depth of the cut. Move the skid-steer as required to allow cutting a new area.

NOTE: Do not move into the stump while making a cross sweep. Machine and/or tooth damage could result from motor overload.

NOTE: Make shallow cuts when cutting surface roots. Large chips can be broken off and thrown if the cut is too deep.

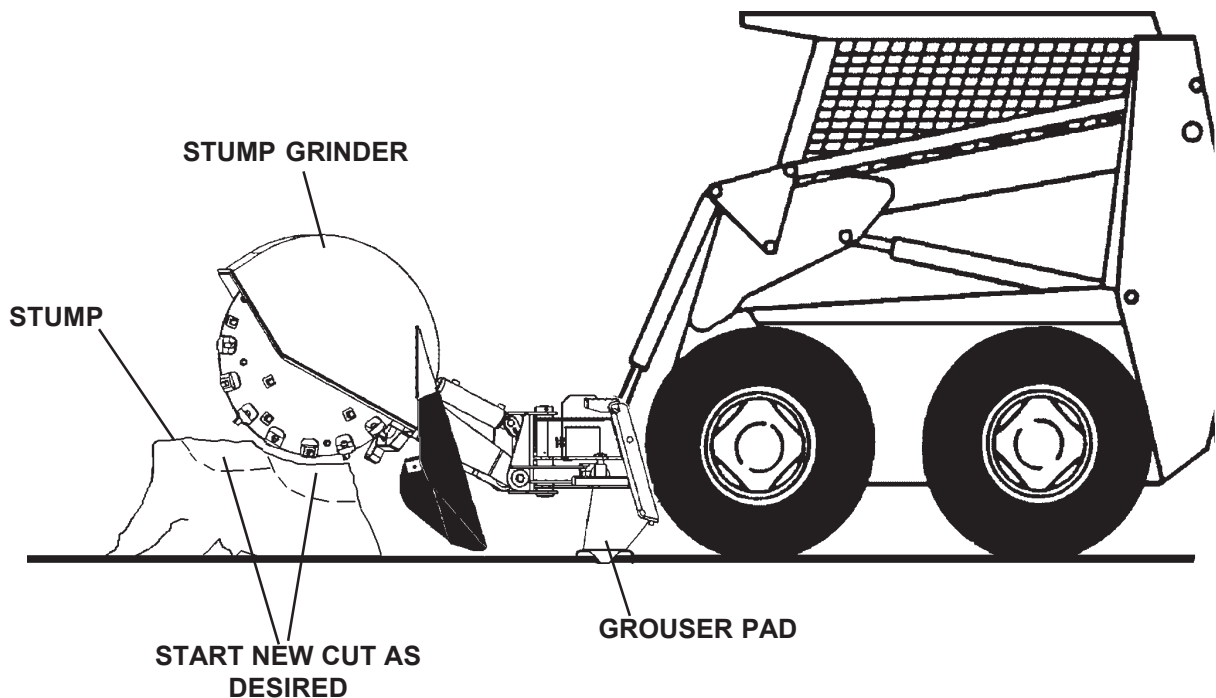

LUBRICATION

GENERAL INFORMATION

Economical and efficient operation of any machine is dependent upon regular and proper lubrication of all moving parts with a quality lubricant. Neglect leads to reduced efficiency, wear, breakdown and needless replacement of parts.

DAILY / EVERY 8 HOURS

All parts provided with grease fittings should be lubricated every 8 hours. If any grease fittings are missing, replace them immediately. Clean all fittings thoroughly before using the grease gun.

IMPORTANT: Avoid excessive greasing. Dirt collects on exposed grease and greatly increases wear. After greasing, wipe off excessive grease from fittings.



LUBRICATION SYMBOL

Lubricate daily or every 8 hours of operation, whichever comes last, with SAE Multi-Purpose Lubricant or equivalent SAE Multi-Purpose type grease.

CAUTION! SHUT OFF ENGINE AND REMOVE KEY BEFORE LUBRICATING EQUIPMENT.

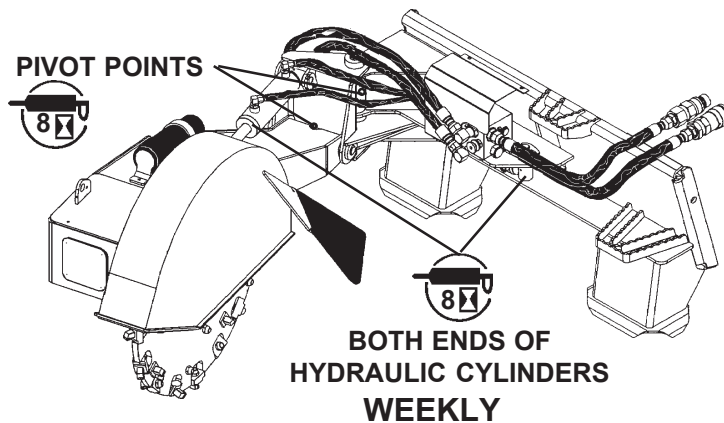

The oil level in the gearbox should be checked once a week. Fill as necessary with 80-90 weight gear lubricant.

TO CHECK:

Remove access cover from front of frame. Remove pipe plug from end of gearbox. Lubricant should be at the same level as the plug.

TO ADD:

Remove pipe plug from the gearbox and add 80-90 weight gear lubricant until level with plug. Replace pipe plug. **NOTE: Removing vent plug when filling will speed up the filling process.**

IMPORTANT: DO NOT OVERFILL, AS TOO MUCH LUBRICANT MAY RUPTURE THE GEARBOX SEALS.

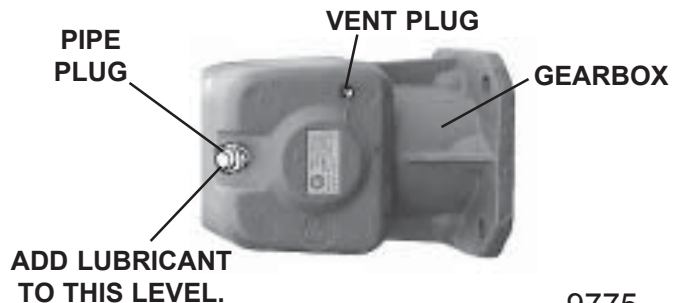

MAINTENANCE

STUMP GRINDERS

GENERAL INFORMATION

Regular maintenance is the key to long equipment life and safe operation. Maintenance requirements have been reduced to an absolute minimum. However, it is very important that these maintenance functions be performed as described below.

WARNING! Avoid serious injury. Lower the stump grinder to the ground, set the parking brake, stop the skid-steer engine and remove the key before leaving the operator's seat. If unit must be left raised for maintenance block the unit securely to prevent accidental release of the lifting mechanism. Disconnect the hydraulic couplers.



DAILY

- Check skid-steer loader hydraulic system to ensure an adequate level of hydraulic oil.
- Check Gearbox castle nut and torque to min. 250 - max. 350 ft. lbs.
- Check mounting hardware on teeth and torque to min. 150- max. 180 ft. lbs.
- Check all other hardware and tighten if necessary. See Section O
- Check hydraulic system for hydraulic oil leaks.
- Check Gearbox power shaft for foreign material wrapped around the shaft and remove if necessary.
- Check teeth for damage and replace as needed.
- Check all Safety Guards and Devices are installed correctly.
- Check for missing or illegible Safety / Warning Decals.

WARNING! Escaping fluid under pressure can have sufficient force to penetrate the skin causing serious personal injury. Fluid escaping from a very small hole can be almost invisible. Use a piece of cardboard or wood, rather than hands to search for suspected leaks.



Keep unprotected body parts, such as face, eyes, and arms as far away as possible from a suspected leak. Flesh injected with hydraulic fluid may develop gangrene or other permanent disabilities.

If injured by injected fluid, see a doctor at once. If your doctor is not familiar with this type of injury, ask him to research it immediately to determine proper treatment.

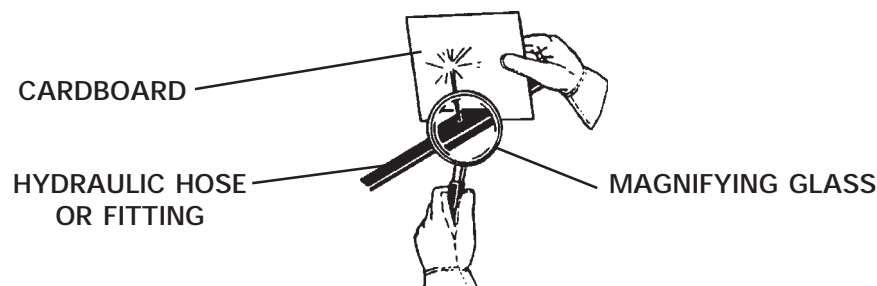

EVERY 40 HOURS

- Check oil level in gearbox and add if necessary. (See Section H)

MAINTENANCE

STUMP GRINDERS

WARNING!  **Avoid serious injury. Lower the stump grinder to the ground, set the parking brake, stop the skid-steer engine and remove the key before leaving the operator's seat. If unit must be left raised for maintenance block the unit securely to prevent accidental release of the lifting mechanism. Disconnect the hydraulic couplers.**

REPLACING TEETH

When replacing the teeth the unit must be blocked securely off the ground to allow the wheel to rotate.

The teeth should be inspected regularly (every 8 hours) for tightness and to ensure they are not worn or that the carbide tip is not missing or chipped. Tighten and replace as necessary.

Replacing Square Teeth:

1. With unit securely blocked off the ground and hydraulic couplers disconnected, remove lock nuts on teeth being replaced.
2. Position new teeth and replace existing lock nut with new one provided.
3. Torque to specification. (See Section "O".)

Replacing Bolt-On Teeth:

1. With unit securely blocked off the ground and hydraulic couplers disconnected, remove the two sockethead capscrews securing the tooth to the wheel.
2. Position the new tooth on one side while retaining the existing tooth on the other side and secure in place with the existing sockethead capscrews.

NOTE: Be sure to maintain the existing tooth pattern when replacing any bolt-on teeth. See Section E

3. Torque to specification. (See Section "O".)

REPLACING HYDRAULIC MOTOR

When replacing the hydraulic motor the unit should be either securely blocked up off the ground or attached to a hoist with the hydraulic couplers disconnected.

NOTE: Field replacement of the internal motor seals voids warranty.

1. With unit securely positioned and hydraulic couplers disconnected, tag and disconnect the hydraulic hoses from the hydraulic motor. Note the hose routing for re-installation.
2. Loosen the four sockethead capscrews on the coupler. See Figure #1
3. **Standard Flow:** Slide the motor out of the coupler and remove the two .50" capscrews holding the motor to the motor mount and remove the motor. See Figure #1
High Flow: Remove the four .50" capscrews holding the motor to the motor mounts and then slide the motor out of the coupler. See Figure #1

MAINTENANCE

STUMP GRINDERS

4. **Standard Flow:** Install the new motor onto the motor mount using the existing hardware. Slide the motor with the mounting plate into the coupler while positioning the rubber bumpers and retighten the sockethead capscrews.
High Flow: Slide the motor into the coupler while maintaining the positioning of the motor mounting plates. Reinstall the motor onto the motor mountings using the existing hardware and retighten the sockethead capscrews.

WARNING! Avoid serious injury. Lower the stump grinder to the ground, set the parking brake, stop the skid-steer engine and remove the key before leaving the operator's seat. If unit must be left raised for maintenance block the unit securely to prevent accidental release of the lifting mechanism. Disconnect the hydraulic couplers.



5. Torque all hardware to specification. See Section O
6. Re-connect the hydraulic hoses and fittings to the new motor.
7. Check for leaks and tighten as required.

FIGURE #1

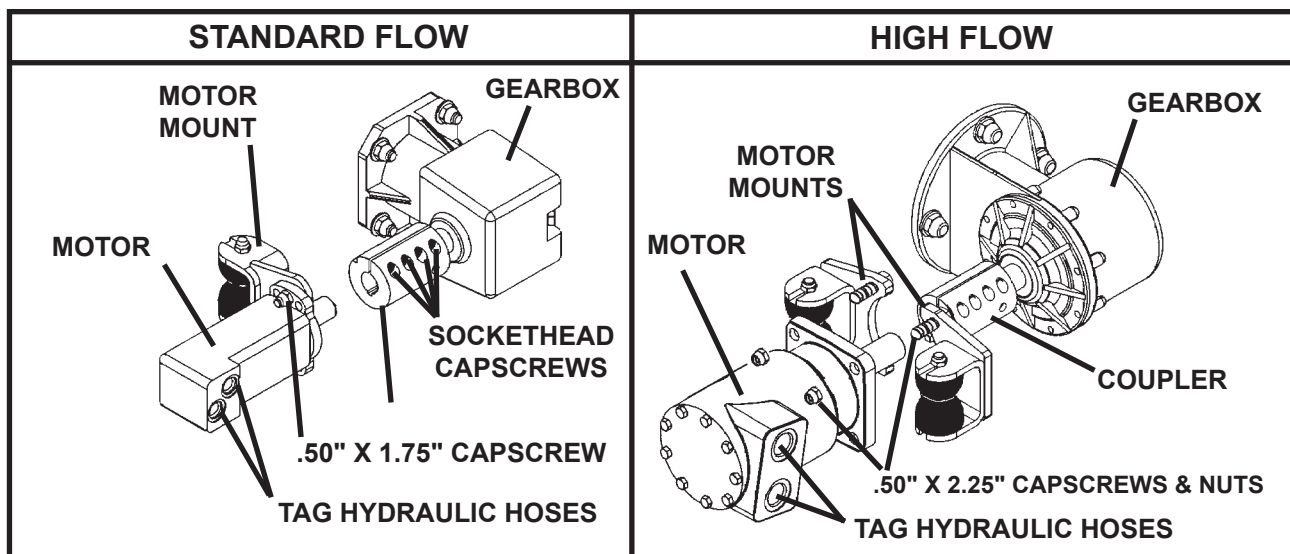

REPLACING GEARBOX/MOTOR COUPLER

When replacing the coupler the unit should be either securely blocked up off the ground or attached to a hoist with the hydraulic couplers disconnected.

1. With unit securely positioned and hydraulic couplers disconnected, loosen the four sockethead capscrews on the coupler.
2. **Standard Flow:** Slide the motor out of the coupler. See Figure #1
High Flow: Remove the four .50" capscrews holding the motor to the motor mounts and slide the motor out of the coupler. See Figure #1
3. Remove the roll pin holding the coupler to the gearbox.
4. Place the new coupler on the gearbox shaft and reinstall the roll pin.

MAINTENANCE

STUMP GRINDERS

- Reinstall the motor into the coupler (install the four .50" capscrews on high flow units) and retighten the sockethead capscrews. Torque to specification. See Section O

REPLACING GEARBOX

When replacing the gearbox the unit should be either securely blocked up off the ground or attached to a hoist with the hydraulic couplers disconnected.

NOTE: A new cotter pin should be installed whenever the wheel has been removed.

- With the wheel guard cover removed, remove the castle nut and cotter pin securing the wheel to the gearbox.
- Loosen the four sockethead capscrews on the coupler. See Figure #1
- Standard Flow:** Slide the motor out of the coupler. See Figure #1
High Flow: Remove the four .50" capscrews holding the motor to the motor mounts and slide the motor out of the coupler. See Figure #1
- Remove the roll pin holding the coupler to the gearbox and remove the coupler. See Figure #2
- Remove the four capscrews securing the gearbox to the stump grinder frame and remove the gearbox. See Figure #2 **NOTE: Be prepared for the gearbox to drop when the capscrews are removed.**

FIGURE #2

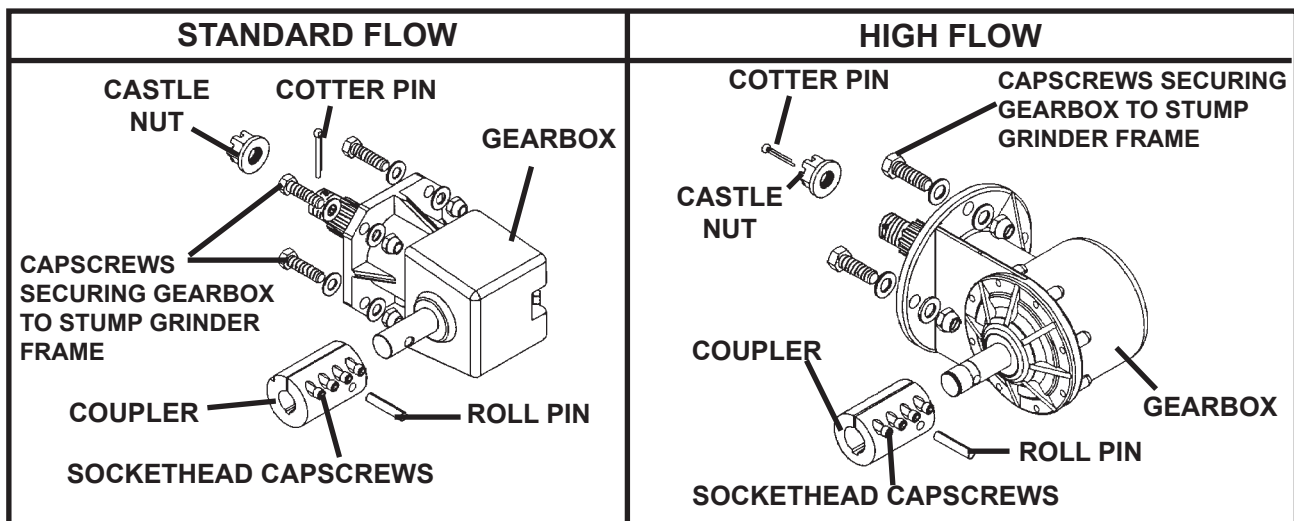

- Check lubrication level in the gearbox and add as needed. See Section H
- Install into the stump grinder frame using the existing hardware.
- Place the new coupler on the gearbox shaft and reinstall the roll pin.
- Reinstall the motor into the coupler (install the four .50" capscrews on high flow units) and retighten the sockethead capscrews.
- Re-install the wheel using the new castle nut and cotter pin.
- Re-install the wheel guard cover using the existing hardware.
- Torque all capscrews to specification. See Section O

MAINTENANCE

CYLINDER SEAL REPLACEMENT

CYLINDER SEAL REPLACEMENT

GENERAL INFORMATION

The following information is provided to assist you in the event you should need to repair or rebuild a hydraulic cylinder. When working on hydraulic cylinders, make sure that the work area and tools are clean and free of dirt to prevent contamination of the hydraulic system and damage to the hydraulic cylinders. Always protect the active part of the cylinder rod (the chrome section). Nicks or scratches on the surface of the rod could result in cylinder failure. Clean all parts thoroughly with a cleaning solvent before reassembly.

DISASSEMBLY PROCEDURE

IMPORTANT: Do not contact the active surface of the cylinder rod with the vise. Damage to the rod could result.

THREADED TYPE GLAND

1. Rotate the gland with a spanner wrench counter-clockwise until the gland is free of the cylinder tube.

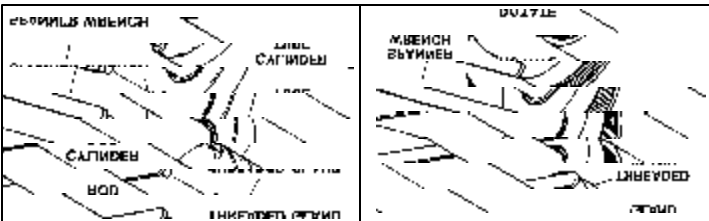

2. Pull the cylinder rod from the cylinder tube.
3. Inspect the piston and the bore of the cylinder tube for deep scratches or galling. If damaged, the piston and cylinder tube must be replaced.

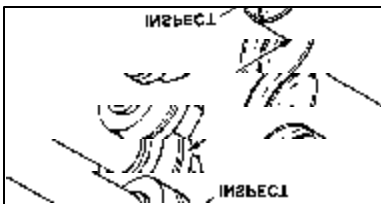

4. Remove the hex nut, piston, flat washer or spacer tube (if so equipped), and gland from the cylinder rod. If the cylinder rod is rusty, scratched, or bent, it must be replaced.
5. Remove and discard all the old seals.

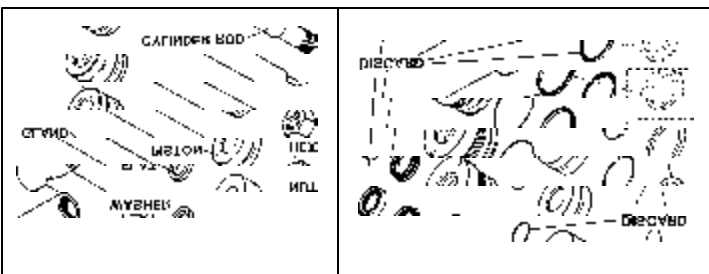

ASSEMBLY PROCEDURE

IMPORTANT: Replace all seals even if they do not appear to be damaged. Failure to replace all seals may result in premature cylinder failure.

1. Install the cylinder rod seal in the gland first. Be careful not to damage the seal in the process as it is somewhat difficult to install.

A special installation tool (Part #65349) is available to help with installing the seal. Simply fit the end of the tool over the seal so that the large prong of the tool is on the outside of the seal, and the two smaller prongs on the inside. The lip of the seal should be facing towards the tool.

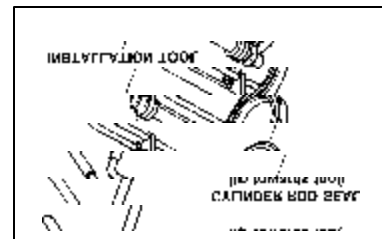

Rotate the handles on the tool around to wrap the seal around the end of the tool.

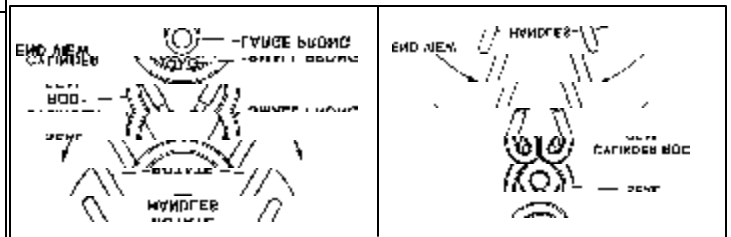

Now insert the seal into the gland from the inner end. Position the seal in its groove, and release and remove the tool. Press the seal into its seat the rest of the way by hand.

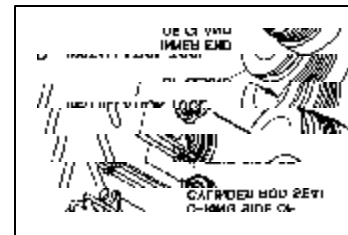

2. Install the new piston ring, rod wiper, O-rings and backup washers if applicable on the piston.

Be careful not to damage the seals. Caution must be used when installing the piston ring. The ring must be stretched carefully over the piston with a smooth, round, pointed tool.

MAINTENANCE

CYLINDER SEAL REPLACEMENT

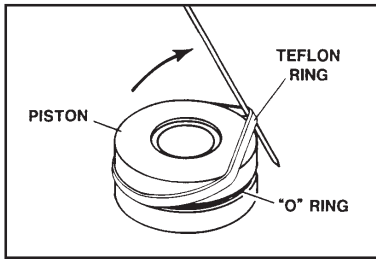

3. After installing the rod seal inside the gland as shown in step #1, install the external seal.

NOTE: Threaded glands may have been equipped with a separate O-ring and backup washer system or a polypak (all in one) type seal. Current seal kits contain a polypak (all in one) type seal to replace the discarded seal types on ALL THREADED GLANDS.

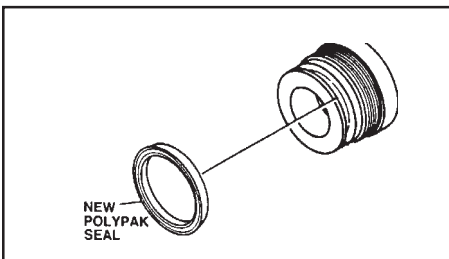

4. Slide the gland onto the cylinder rod being careful not to damage the rod wiper. Then install the spacer, or flat washer (if so equipped), small o-ring, piston, and hex nut onto the end of the cylinder rod.

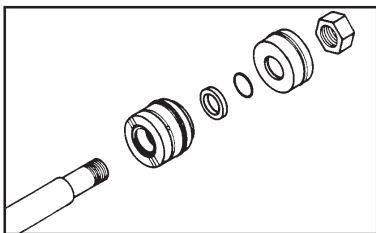

5. Secure the cylinder rod (mounting end) in a vise with a support at it's center. Torque the nut to the amount shown for the thread diameter of the cylinder rod (see chart).

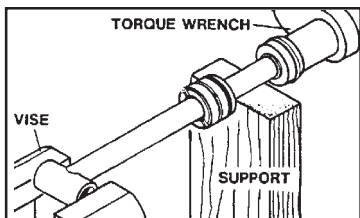

IMPORTANT: Do not contact the active surface of the cylinder rod with the vise. Damage to the rod could result.

6. Apply a lubricant (such as Lubriplate #105) to the piston and teflon ring. Insert the cylinder rod assembly into the cylinder tube.

IMPORTANT: Ensure that the piston ring fits squarely into the cylinder tube and piston groove, otherwise the ring may be damaged and a leak will occur.

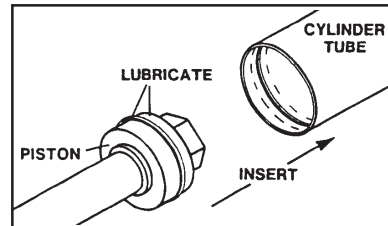

7. Use a spanner wrench to rotate the gland clockwise into the cylinder. Continue to rotate the gland with the spanner wrench until it is tight.

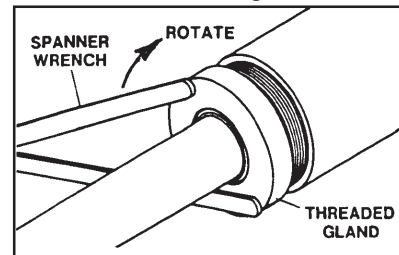

NOTE: Seal kits will service most cylinders of similar bore size and rod diameter.

WARNING!



Cylinders serviced in the field are to be tested for leakage prior to the attachment being placed in work. Failure to test rebuilt cylinders could result in damage to the cylinder and/or the attachment, cause severe personal injury or even death.

TORQUE SPECIFICATION CHART

Use the following torque values when tightening the nuts on the cylinder rod threads.

Thread Diameter	POUNDS - FEET	
	Minimum	Maximum
7/8"	150	200
* 1"	230	325
1-1/8"	350	480
1-1/4"	490	670
1-3/8"	670	900

* 1" Thread Diameter WITH 1.25" Rod Diameter
 Min. 230 ft. lbs. Max. 250 ft. lbs.

STORAGE & TRANSPORTING

STUMP GRINDER

GENERAL INFORMATION

The following storage procedure will help you to keep your stump grinder in top condition. It will also help you get off to a good start the next time your stump grinder is needed. We therefore strongly recommend that you take the extra time to follow these procedures whenever your unit will not be used for an extended period of time.

PREPARATION FOR STORAGE

1. Clean the unit thoroughly, removing all mud, dirt, grease and wood chips.
2. Replace any worn or chipped teeth. Replace any teeth that are missing the carbide tip.
3. Inspect the unit for visible signs of wear, breakage or damage. Order any parts required and make the necessary repairs to avoid delays when starting next season.
NOTE: Purchase only approved parts from your authorized dealer.
4. Tighten all loose nuts, capscrews and hydraulic connections.
5. Check the gearbox for proper lubrication level. (See Section H)
6. Connect the hydraulic couplers together to protect the hydraulic system from contaminants.
7. Touch up all unpainted and exposed areas with paint to prevent rust.
8. Replace decals if damaged or in unreadable condition.
9. Coat exposed ends of the cylinder rods with grease.
10. Grease all grease fittings. (See Section H)
11. Store the unit in a dry and protected place. Leaving the unit outside will materially shorten its life.

REMOVING FROM STORAGE

1. Remove all protective coverings.
2. Check hydraulic hoses for deterioration and replace if necessary.
3. Check all nuts and bolts for tightness, especially those securing the motor, gearbox and teeth.

TRANSPORTING

1. Follow all federal, state and local regulations when transporting on public roads.
2. Use extra care when loading or unloading onto a trailer or truck.

CAUTION: Be sure to install a **SMV (Slow Moving Vehicle)** sign on loader before transporting.



When transporting on a road or highway at night or during the day, use accessory lights and devices for adequate warning to the operators of other vehicles. In this regard, check local and government regulations. Always drive slowly over uneven terrain to avoid tipping the unit.

TROUBLESHOOTING

<u>PROBLEM</u>	<u>POSSIBLE CAUSE</u>	<u>POSSIBLE REMEDY</u>
Motor will not operate.	Auxiliary hoses not hooked up to the skid-steer.	Engage Couplers
	Obstruction in hydraulic lines.	Remove obstruction and replace if necessary.
	Skid-steer auxiliary valve not engaged.	Engage auxiliary valve.
Wheel rotates sluggishly.	Insufficient hydraulic flow from the skid-steer.	Refer to skid-steer's owners manual.
	Damaged quick coupler.	Replace if necessary.
	Oil filter on skid-steer is dirty.	Refer to skid-steer's owners manual.
	Internal motor leakage.	Call Bradco service department.
	Gearbox Failure.	Call Bradco service department.
Leaking Oil.	Loose or damaged hydraulic line.	Tighten or replace.
	O-Rings on fittings damaged.	Replace if necessary.
	Fittings loose or damaged.	Tighten or replace.
	Cylinder seals damaged.	Replace cylinder seals.
	Motor seals damaged.	Call Bradco Service Department.
Insufficient power.	Insufficient hydraulic flow from the skid-steer.	Refer to skid-steer's owners manual.
	Relief valve setting adjusted too low.	Refer to skid-steer's owners manual.
	Oil filter on skid-steer is dirty.	Refer to skid-steer's owners manual.
Cylinders operate in the wrong direction.	Hoses from the valve to the skid-steer incorrectly connected.	Switch couplers at the skid steer end.
	Incorrect wiring from the joystick control.	Check wiring diagram and correct.
Cylinders speed is either too fast or too slow.	Cylinder speed adjusted incorrectly.	Adjust the cylinder speed knob on the control valve.

TROUBLESHOOTING

<u>PROBLEM</u>	<u>POSSIBLE CAUSE</u>	<u>POSSIBLE REMEDY</u>
Excessive oil temperature.	Hydraulic oil level too low.	Refer to skid-steer's owners manual
	Excessive stalling of cutting wheel.	Decrease cutting depth and swing speed.
	Obstruction in hydraulic lines.	Remove obstruction and replace if necessary.
	Hydraulic oil or oil filter in skid-steer is dirty.	Refer to skid-steer's owners manual.
	Relief valve setting adjusted too low.	Refer to skid-steer's owners manual.
	Couplers not engaged.	Engage couplers.
Wheel rotates in the wrong direction.	Hoses are switched at the motor.	Switch motor hoses.
Excessive Vibration	Broken, damaged or missing teeth.	Replace as necessary.
	Bent gearbox shaft.	Call Bradco Service Department.
Cylinders will not function.	Faulty switch or electrical connection.	Repair or replace as necessary.
	Faulty control valve coil.	Replace coil.
	Damaged spool in control valve.	Replace spool.



BOLT TORQUE

BOLT TORQUE SPECIFICATIONS

GENERAL TORQUE SPECIFICATION TABLE

Use the following torques when special torques are not given. These values apply to fasteners as received from suppliers, dry, or when lubricated with normal engine oil. They do not apply if special graphited or moly disulphide greases or other extreme pressure lubricants are used. This applies to both UNF and UNC threads. Remember to always use grade five or better when replacing bolts.

SAE Grade No.		2				5				8*				
Bolt head identification marks as per grade. NOTE: Manufacturing Marks Will Vary														
		TORQUE		TORQUE		TORQUE		TORQUE		TORQUE		TORQUE		
Bolt Size	Inches	Millimeters	Pounds Feet		Newton-Meters		Pounds Feet		Newton-Meters		Pounds Feet		Newton-Meters	
			Min.	Max.	Min.	Max.	Min.	Max.	Min.	Max.	Min.	Max.	Min.	Max.
1/4	6.35		5	6	6.8	8.13	9	11	12.2	14.9	12	15	16.3	30.3
5/16	7.94		10	12	13.6	16.3	17	20.5	23.1	27.8	24	29	32.5	39.3
3/8	9.53		20	23	27.1	31.2	35	42	47.5	57.0	45	54	61.0	73.2
7/16	11.11		30	25	40.7	47.4	54	64	73.2	86.8	70	84	94.9	113.9
1/2	12.70		45	52	61.0	70.5	80	96	108.5	130.2	110	132	149.2	179.0
9/16	14.29		65	75	88.1	101.6	110	132	149.2	179.0	160	192	217.0	260.4
5/8	15.88		95	105	128.7	142.3	150	180	203.4	244.1	220	264	298.3	358.0
3/4	19.05		150	185	203.3	250.7	270	324	366.1	439.3	380	456	515.3	618.3
7/8	22.23		160	200	216.8	271.0	400	480	542.4	650.9	600	720	813.6	976.3
1	25.40		250	300	338.8	406.5	580	696	786.5	943.8	900	1080	1220.4	1464.5
1-1/8	25.58		-	-	-	-	800	880	1084.8	1193.3	1280	1440	1735.7	1952.6
1-1/4	31.75		-	-	-	-	1120	1240	1518.7	1681.4	1820	2000	2467.9	2712.0
1-3/8	34.93		-	-	-	-	1460	1680	1979.8	2278.1	2380	2720	3227.3	3688.3
1-1/2	38.10		-	-	-	-	1940	2200	2630.6	2983.2	3160	3560	4285.0	4827.4

* Thick Nuts must be used with Grade 8 bolts

METRIC BOLT TORQUE SPECIFICATIONS

Size of Screw	Grade No.	Coarse Thread			Fine Thread		
		Ptich (mm)	Pounds Feet	Newton-Meters	Pitch (mm)	Pounds Feet	Newton-Meters
M6	5.6	1.0	3.6-5.8	4.9-7.9	-	-	-
	8.8		5.8-9.4	7.9-12.7		-	-
	10.9		7.2-10	9.8-13.6		-	-
M8	5.6	1.25	7.2-14	9.8-19	1.0	12-17	16.3-23
	8.8		17-22	23-29.8		19-27	25.7-36.6
	10.9		20-26	27.1-35.2		22-31	29.8-42
M10	5.6	1.5	20-25	27.1-33.9	1.25	20-29	27.1-39.3
	8.8		34-40	46.1-54.2		35-47	47.4-63.7
	10.9		38-46	51.5-62.3		40-52	54.2-70.5
M12	5.6	1.75	28-34	37.9-46.1	1.25	31-41	42-55.6
	8.8		51-59	69.1-79.9		56-68	75.9-92.1
	10.9		57-66	77.2-89.4		62-75	84-101.6
M14	5.6	2.0	49-56	66.4-75.9	1.5	52-64	70.5-86.7
	8.8		81-93	109.8-126		90-106	122-143.6
	10.9		96-109	130.1-147.7		107-124	145-168
M16	5.6	2.0	67-77	90.8-104.3	1.5	69-83	93.5-112.5
	8.8		116-130	157.2-176.2		120-138	162.6-187
	10.9		129-145	174.8-196.5		140-158	189.7-214.1
M18	5.6	2.0	88-100	119.2-136	1.5	100-117	136-158.5
	8.8		150-168	203.3-227.6		177-199	239.8-269.6
	10.9		175-194	237.1-262.9		202-231	273.7-313
M20	5.6	2.5	108-130	146.3-176.2	1.5	132-150	178.9-203.3
	8.8		186-205	252-277.8		206-242	279.1-327.9
	10.9		213-249	288.6-337.4		246-289	333.3-391.6

SPECIFICATIONS

STUMP GRINDER

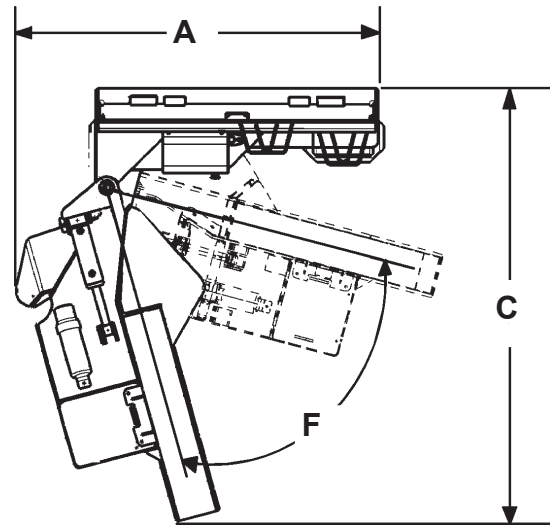
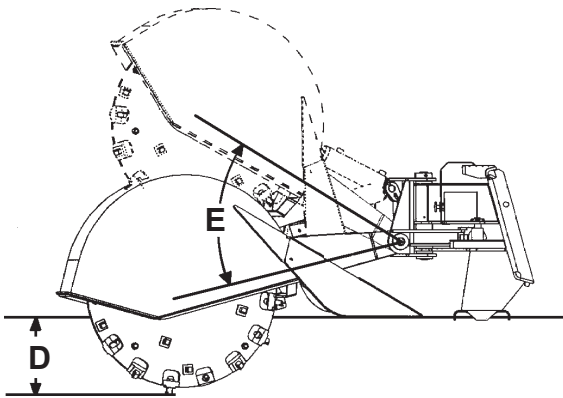

SPECIFICATION AND DESIGN ARE SUBJECT TO CHANGE WITHOUT NOTICE AND WITHOUT LIABILITY THEREFORE.

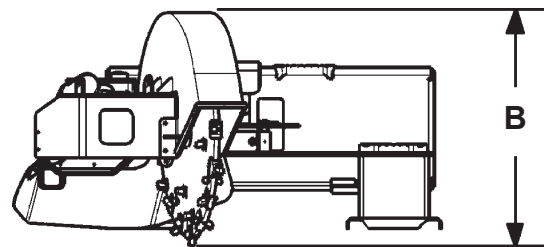

DESCRIPTION	SPECIFICATION	
A. Overall Width	58.00"	
B. Overall Height	37.00"	
C. Overall Length	73.00"	
D. Below Ground Depth	12.00"	
E. Swing Arc	60°	
F. Maximum Lift	43°	
Number of Cutting Teeth	28	
	STANDARD FLOW	HIGH FLOW
Wheel Diameter	26.00"	30.00"
Hydraulic Flow Requirement.....	16-22 GPM	25-40 GPM
Weight (lbs)	720#	795#
Stump Height (with gouser pads on the ground and measuring to centerline of cutting wheel).....	30"	30"

DECALS

DECAL PLACEMENT

GENERAL INFORMATION

The diagram on this page shows the location of the decals used on the BRADCO Rear Discharge Stump Grinders. The decals are identified by their part numbers, with reductions of the actual decals located on the following pages. Use this information to order replacements for lost or damaged decals. Be sure to read all decals before operating the stump grinder. They contain information you need to know for both safety and attachment longevity.

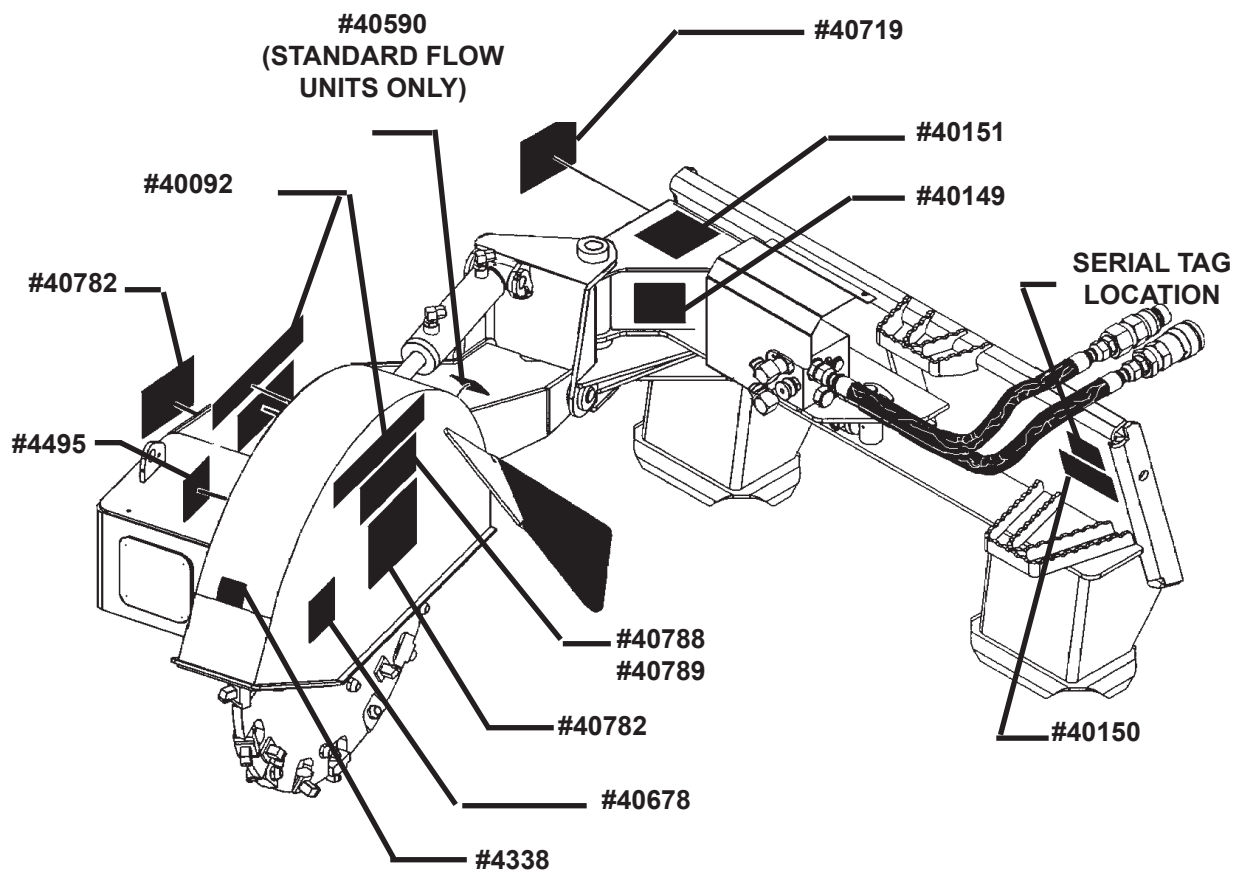

IMPORTANT: Keep all safety signs clean and legible. Replace all missing, illegible or damaged safety signs. When replacing parts with safety signs attached, the safety signs must also be replaced.

REPLACING SAFETY DECALS: Clean the area of application with a nonflammable solvent, then wash the same area with soap and water. Allow the surface to dry. Remove the backing from the safety sign, exposing the adhesive surface. Apply the safety sign to the position shown in the diagram above and smooth out any bubbles.

DECALS



DANGER! ROTATING BLADE
PART #40782



WARNING! HIGH PRESSURE FLUID
PART #40151



DANGER! FLYING DEBRIS
PART #40719



DANGER! PINCH POINT
PART #40149

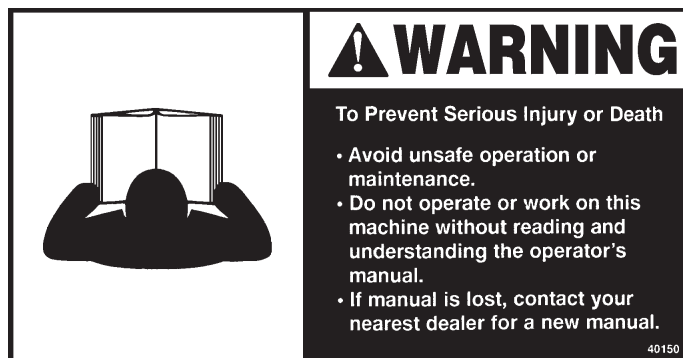

WARNING! READ OPERATOR'S MANUAL
PART #40150

DECALS



WARNING! GUARD REMOVED
PART #4495



WARNING! BEFORE LEAVING OPERATOR'S SEAT
PART #40678



CAUTION! DO NOT OPERATE
PART #40590
(USED ON STANDARD FLOW UNITS ONLY!)



MADE IN U.S.A.
PART #4338

BRADCO®

BRADCO LOGO
PART #40092

SG26

MODEL NUMBER
PART #40787

SG30

MODEL NUMBER
PART #40788

PREDELIVERY CHECKLIST

GENERAL INFORMATION

The following is a list of areas that should be inspected by the dealer prior to delivery of the attachment to the customer. The customer should check the list and make sure that the dealer has completed the inspection. Completion of this checklist will help insure that the customer receives the attachment in complete working order, ready to install.

PREDELIVERY CHECKLIST - CHECK AND ADJUST AS NECESSARY

1. _____ Visually inspect the attachment for bent, cracked, damaged or missing parts. Check for any other irregularities.
2. _____ Check and lubricate attachment if necessary. See "Lubrication" Section H.
3. _____ Check bolts for tightness daily. Retighten after the first eight working hours.
4. _____ Remove paint from unfinished chrome surfaces of cylinders.
5. _____ Run cylinders through their full cycle to purge any air from the system.
6. _____ Check all hydraulic connections for leaks and hoses for proper positioning to reduce chafing and binding.
7. _____ Make sure all decals are not damaged or missing and are in their correct location. See "Decals" Section Q.
8. _____ Make sure customer has the necessary couplers to attach the power and return hoses to the skid-steer auxiliary hydraulic couplers.
9. _____ Complete and return the manufacturers "Warranty Validation Form" and sign your dealership predelivery checklist.

LIMITED WARRANTY

All new Bradco products are warranted to be free from defects in materials or workmanship which may cause failure under normal usage and service when used for the purpose intended.

In the event of failure within twelve (12) months from initial retail sale, lease or rental date (excluding cable, ground engaging parts such as sprockets, digging chain, bearings, teeth, tamping and demolition heads, blade cutting edges, pilot bits, auger teeth, auger heads & broom bristles), if after examination, Bradco determines failure was due to defective material and/or workmanship, parts will be repaired or replaced. Bradco may request defective part or parts be returned prepaid to them for inspection at their place of business at Delhi, Iowa, or to a location specified by Bradco.

Any claims under this warranty must be made within fifteen (15) days after the Buyer learns of the facts upon which such claim is based. All claims not made in writing and received by Bradco within the time period specified above shall be deemed waived.

THIS WARRANTY IS IN LIEU OF ALL OTHER WARRANTIES EXPRESSED OR IMPLIED AND THERE ARE NO WARRANTIES OF MERCHANTABILITY OR OF FITNESS FOR A PARTICULAR PURPOSE. IN NO EVENT SHALL BRADCO BE LIABLE FOR CONSEQUENTIAL OR SPECIAL DAMAGE.

BRADCO'S LIABILITY FOR ANY AND ALL LOSSES AND DAMAGES TO BUYER, RESULTING FROM ANY CAUSE WHATSOEVER, INCLUDING BRADCO'S NEGLIGENCE, IRRESPECTIVE OF WHETHER SUCH DEFECTS ARE DISCOVERABLE OR LATENT, SHALL IN NO EVENT EXCEED THE PURCHASE PRICE OF THE PARTICULAR PRODUCTS WITH RESPECT TO WHICH LOSSES OR DAMAGES ARE CLAIMED, OR, AT THE ELECTION OF BRADCO, THE REPAIR OR REPLACEMENT OF DEFECTIVE OR DAMAGED PRODUCTS.