



# OPERATOR'S & PARTS MANUAL

## COMPACT TRACTOR MANURE FORK GRAPPLE



PALADIN LIGHT CONSTRUCTION

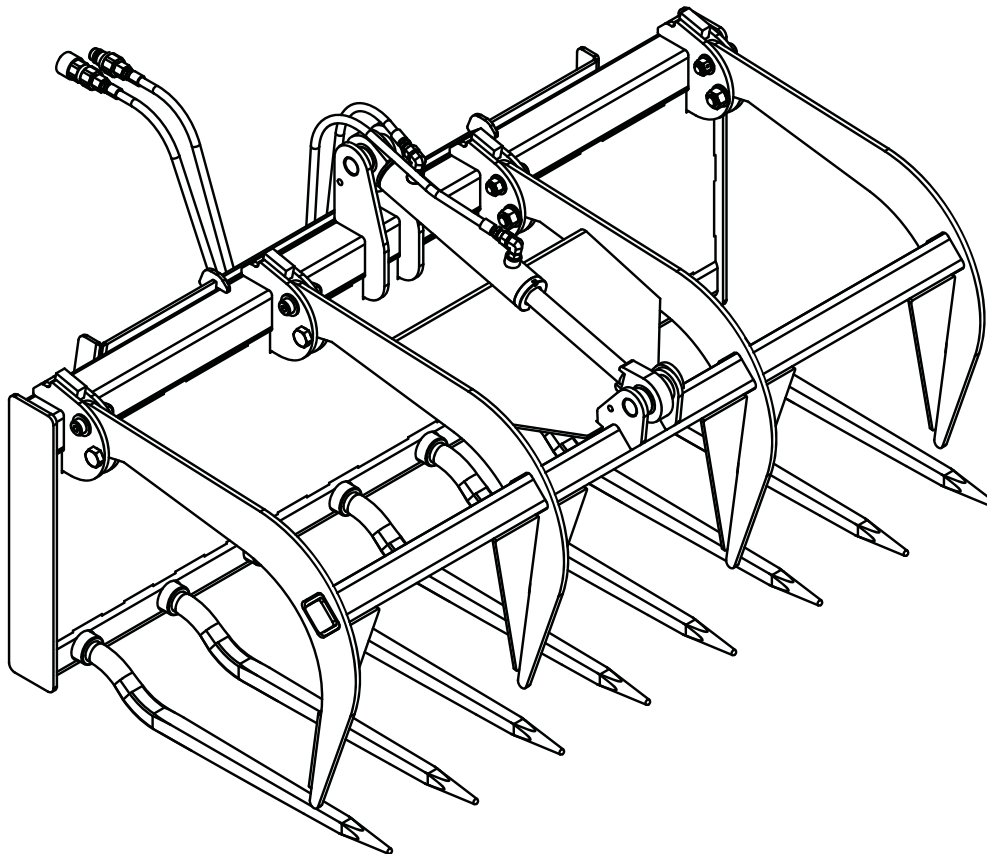

SERIAL NUMBER: \_\_\_\_\_

MODEL NUMBER: \_\_\_\_\_

Manual Number: 51-10031

Model: 10708

Date: August 2007



# TABLE OF CONTENTS

INTRODUCTION .....	2
GENERAL INFORMATION .....	2
SERIAL NUMBER .....	2
OWNER AND OPERATOR SAFETY INFORMATION	
SAFETY STATEMENTS .....	3
SAFETY PRECAUTIONS .....	3-5
SAFETY SIGNS .....	6-7
SPECIFICATIONS .....	8
MOUNTING .....	9
OPERATION .....	10
MAINTENANCE .....	11
SERVICE .....	11
PARTS ILLUSTRATION .....	12
PARTS LIST .....	13
WARRANTY .....	i

## INTRODUCTION

Congratulations on your purchase of a new FFC Compact Tractor Manure Fork Grapple. This product has been designed and built for moving loose hay, manure, brush and small branches. You or any other person who will be assembling, operating, maintaining, or working with this product are required to read and completely understand the information and instructions contained in this manual. If anyone does not fully understand every part of this manual, please obtain further assistance by contacting the dealer from which this product was purchased or by contacting FFC at the telephone number or address listed on the cover of this manual. Keep this manual available for reference whenever this product is being handled or used. Provide this manual to any new owners and/or operators.

This manual covers model(s) 10708.

## GENERAL INFORMATION

The purpose of this manual is to assist in assembling, mounting, operating, and maintaining your attachment. Read this manual carefully to obtain valuable information and instructions that will help you achieve years of safe and dependable service.

The illustrations and data used in this manual were current at the time of printing, but due to possible engineering and/or production changes, this product may vary slightly in detail. FFC reserves the right to redesign and/or change components as may be necessary without notification to anyone.

Throughout this manual, references may be made to:

Tractor	The engine-driven machine to which this product must be attached.
Right, Left, Front, Rear	Directions that are determined in relation to the operator of the equipment when seated in the normal operation position.
<b>IMPORTANT</b>	Precautions that must be followed to prevent substandard performance.

## SERIAL NUMBER LOCATION

Always refer to the model and serial number when ordering parts or requesting information from your dealer. See Safety Signs section for the location of the serial number plate for this product.

Reference Information	
Model Number	Tractor Make & Model
Serial Number	Loader Model
Date Purchased	Loader Serial Number

# SAFETY STATEMENTS



**THIS SYMBOL BY ITSELF OR WITH A WARNING WORD THROUGHOUT THIS MANUAL IS USED TO CALL YOUR ATTENTION TO INSTRUCTIONS INVOLVING YOUR PERSONAL SAFETY OR THE SAFETY OF OTHERS. FAILURE TO FOLLOW THESE INSTRUCTIONS CAN RESULT IN INJURY OR DEATH.**



**DANGER**

**THIS SIGNAL WORD IS USED WHERE SERIOUS INJURY OR DEATH WILL RESULT IF THE INSTRUCTIONS ARE NOT FOLLOWED PROPERLY.**



**WARNING**

**THIS SIGNAL WORD IS USED WHERE SERIOUS INJURY OR DEATH COULD RESULT IF THE INSTRUCTIONS ARE NOT FOLLOWED PROPERLY.**



**CAUTION**

**THIS SIGNAL WORD IS USED WHERE MINOR INJURY COULD RESULT IF THE INSTRUCTIONS ARE NOT FOLLOWED PROPERLY.**

**NOTICE**

**NOTICE INDICATES A PROPERTY DAMAGE MESSAGE.**

## GENERAL SAFETY PRECAUTIONS

### **WARNING! READ MANUAL PRIOR TO INSTALLATION**



Improper installation, operation, or maintenance of this equipment could result in serious injury or death. Operators and maintenance personnel should read this manual, as well as all manuals related to this equipment and the tractor thoroughly before beginning installation, operation, or maintenance. **FOLLOW ALL SAFETY INSTRUCTIONS IN THIS MANUAL AND THE TRACTOR'S MANUAL(S).**



### **READ AND UNDERSTAND ALL SAFETY STATEMENTS**

Read all safety decals and safety statements in all manuals prior to operating or working on this equipment. Know and obey all OSHA regulations, local laws, and other professional guidelines for your operation. Know and follow good work practices when assembling, maintaining, repairing, mounting, removing, or operating this equipment.



### **KNOW YOUR EQUIPMENT**

Know your equipment's capabilities, dimensions and operations before operating. Visually inspect your equipment before you start, and never operate equipment that is not in proper working order with all safety devices intact. Check all hardware to ensure it is tight. Make certain that all locking pins, latches, and connection devices are properly installed and secured. Remove and replace any damaged, fatigued, or excessively worn parts. Make certain all safety decals are in place and are legible. Keep decals clean, and replace them if they become worn and hard to read.

## GENERAL SAFETY PRECAUTIONS

### WARNING! PROTECT AGAINST FLYING DEBRIS



Always wear proper safety glasses, goggles or a face shield when driving pins in or out, or when any operation causes dust, flying debris, or any other hazardous material.

### WARNING! LOWER OR SUPPORT RAISED EQUIPMENT



Do not work under raised booms without supporting them. Do not use support material made of concrete blocks, logs, buckets, barrels or any other material that could suddenly collapse or shift positions. Make sure support material is solid, not decayed, warped, twisted, or tapered. Lower booms to ground level or onto blocks. Lower booms and attachments to the ground before leaving the cab or operator's station.

### WARNING! USE CARE WITH HYDRAULIC FLUID PRESSURE



Hydraulic fluid under pressure can penetrate the skin and cause serious injury or death. Hydraulic leaks under pressure may not be visible. Before connecting or disconnecting hydraulic hoses, read your tractor's operator's manual for detailed instructions on connecting and disconnecting hydraulic hoses or fittings.

- Keep unprotected body parts, such as face, eyes, and arms as far away as possible from a suspected leak. Flesh injected with hydraulic fluid may develop gangrene or other permanent disabilities.
- If injured by injected fluid, see a doctor at once. If your doctor is not familiar with this type of injury, ask him to research immediately to determine proper treatment.
- Wear safety glasses, protective clothing, and use a sound piece of cardboard or wood when searching for hydraulic leaks. **DO NOT USE YOUR HANDS!** **SEE ILLUSTRATION.**

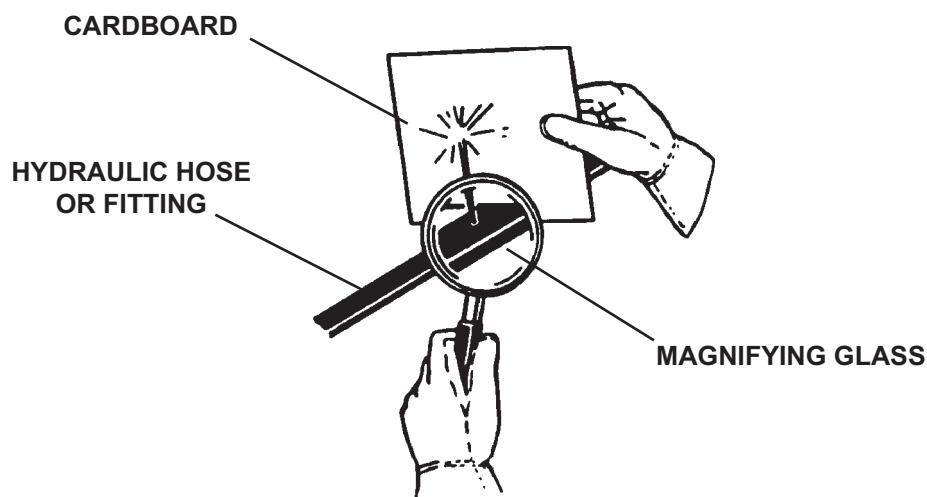

# GENERAL SAFETY PRECAUTIONS

## **WARNING! DO NOT MODIFY MACHINE OR ATTACHMENTS**



Modifications may weaken the integrity of the attachment and may impair the function, safety, life, and performance of the attachment. When making repairs, use only the manufacturer's genuine parts, following authorized instructions. Other parts may be substandard in fit and quality. Never modify any ROPS (Roll Over Protection Structure) or FOPS (Falling Object Protective Structure) equipment or device. Any modifications must be authorized in writing by the manufacturer.

## **WARNING! SAFELY MAINTAIN AND REPAIR EQUIPMENT**



- Do not wear loose clothing, or any accessories that can catch in moving parts. If you have long hair, cover or secure it so that it does not become entangled in the equipment.
- Work on a level surface in a well-lit area.
- Use properly grounded electrical outlets and tools.
- Use the correct tool for the job at hand. Make sure they are in good condition for the task required.
- Wear the protective equipment specified by the tool manufacturer.

## **WARNING! SAFELY OPERATE EQUIPMENT**



Do not operate equipment until you are completely trained by a qualified operator in how to use the controls, know its capabilities, dimensions, and all safety requirements. See your machine's manual for these instructions.

- Keep all step plates, grab bars, pedals, and controls free of dirt, grease, debris, and oil.
- Never allow anyone to be around the equipment when it is operating.
- Do not allow riders on the attachment or the tractor.
- Do not operate the equipment from anywhere other than the correct operators position.
- Never leave equipment unattended with the engine running or with this attachment in a raised position.
- Do not alter or remove any safety feature from the tractor or this attachment.
- Know your work site safety rules as well as traffic rules and flow. When in doubt on any safety issue, contact your supervisor or safety coordinator for an explanation.

## **WARNING! KNOW WHERE UTILITIES ARE**



Observe overhead electrical and other utility lines. Be sure equipment will clear them. When digging, call your local utilities for location of buried utility lines, gas, water, and sewer, as well as any other hazard you may encounter.

# SAFETY SIGN LOCATIONS

The diagram on this page shows the location of the decals used of the FFC Manure Fork Grapple. The decals are identified by their part numbers, with reductions of the actual decals located on the following page. Use this information to order replacements for lost or damaged decals. Be sure to read all decals before operating the attachment. They contain information you need to know for both safety and product longevity.

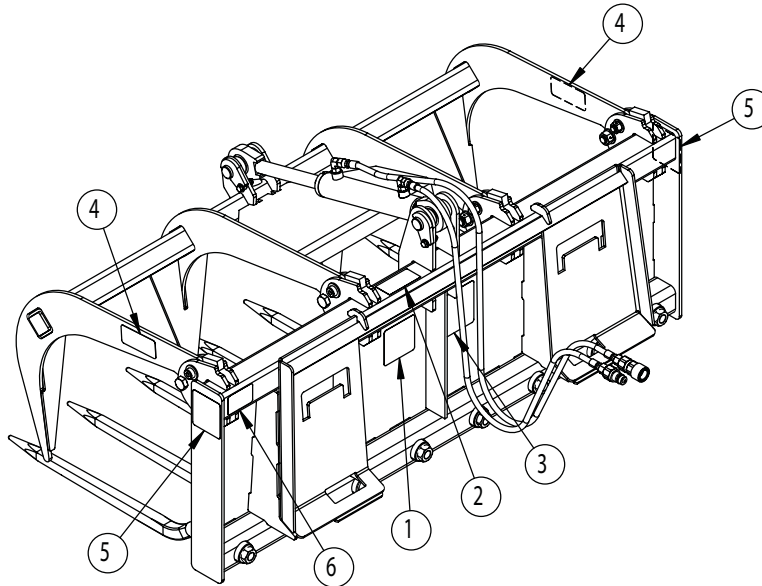

ITEM	QTY.	PART #	DESCRIPTION
1	1	40151	High Pressure Fluid
2	1	40967	Specifications
3	1	1002423	Read Manual
4	2	50-0737	Pinch Point
5	2	RDL3125	Crush Hazard
6	1	----	Serial Number Plate

## INSTRUCTIONS

- Keep all safety signs clean and legible.
- Replace all missing, illegible, or damaged safety signs.
- Replacement parts for parts with safety signs attached must also have safety signs attached.
- Safety signs are available, free of charge, from your dealer or from FFC.

## PLACEMENT OR REPLACEMENT OF SAFETY SIGNS

1. Clean the area of application with non-flammable solvent, and then wash the same area with soap and water.
2. Allow the surface to fully dry.
3. Remove the backing from the safety sign, exposing the adhesive surface.
4. Apply the safety sign to the position shown in the diagram above and smooth out any bubbles.

# SAFETY SIGNS

ITEM 1



ITEM 2



ITEM 3



ITEM 4



ITEM 5



ITEM 6

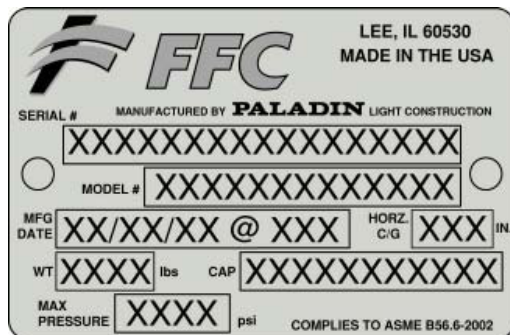

## TRACTOR/LOADER SPECIFICATIONS

**IMPORTANT** Exceeding any of the maximum recommended tractor/loader specifications **CAN** result in damage to this product and **WILL** void all FFC warranties.

DESCRIPTION	SPECIFICATIONS
Tractor HP	40 HP maximum
Operating Weight of Tractor	4,000 lbs. maximum
Lift Capacity of Tractor's Loader	2,000 lbs. maximum
Rear Ballast	As required to maintain full tractor stability. (Note the shipping weight of your model, then see the operator's manual(s) for your tractor and loader for ballasting needs.)

## ATTACHMENT SPECIFICATIONS

Model Number	Overall Width	Overall Height	Overall Depth	Grapple Opening	Shipping Weight
10708-60	60"	25"	30"	37"	450#
10708-72	72"	25"	30"	37"	475#
10708-84	84"	25"	30"	37"	525#
10708-96	96"	25"	30"	37"	600#

## TORQUE SPECIFICATIONS FOR STANDARD MACHINE HARDWARE (FOR REFERENCE ONLY)

Bolt Size	SAE Grade Bolt	Torque Ft./Lbs
3/8" - 16	5	30
5/8" - 11	5	150
3/4 " - 10	5	300
M24 Tine Nut	n/a	300

## MOUNTING

### **WARNING! READ MANUAL PRIOR TO INSTALLATION**



Improper installation, operation, or maintenance of this equipment could result in serious injury or death. Operators and maintenance personnel should read this manual, as well as all manuals related to this equipment and the tractor/loader thoroughly before beginning installation, operation, or maintenance. **FOLLOW ALL SAFETY INSTRUCTIONS IN THIS MANUAL AND THE TRACTOR'S MANUAL(S).**

1. Place this product on a firm, level surface that is large enough to safely accommodate this product, your tractor/loader and all workers involved in the mounting process.
2. Refer to the operator's manual(s) for your tractor and loader. Follow the mounting instructions contained therein.
3. Carefully raise the loader and cycle the tilt cylinders to check clearances and to verify that all mounting procedures have been successfully completed.

# OPERATION

**Read all Safety Precautions before operating your new attachment.  
Refer to your machine's operator's manual for attachment operation.**

The manure fork grapple was designed for moving loose hay, manure, brush and small branches.

1. Depending on the material being moved, approach so the fork tines are either centered under the load (brush or branches) or "stabbing" into the load (pile of hay or manure).
2. Close the grapples to their fullest extent possible and lift the attachment slightly to be certain that the load is secure.

NOTE: If the load appears to be unstable, lower the forks to the ground, open the grapples and reposition the load to attain full stability. Repeat until full stability is achieved.

When using the grapples as a rake to drag materials into position for pick up, THE GRAPPLES MUST BE COMPLETELY OPEN.

**NOTICE** Applying a raking-type force to partially open grapples will greatly magnify the fluid pressure in the hydraulic hoses, fittings, and cylinders and may cause component failure.



**Never heap load heavy material where the combined weight of the attachment and material could exceed the rated lifting capacity of the loader.**

**Be sure the load does not stick out too far in front of the bucket. A light load sticking out too far can have the same tipping effect as a heavy load carried in close.**

**Operate the attachment only when properly seated at the operator's station. Do not exceed the lift capacity of your loader. See loader specifications. Do not handle round bales.**

**When using the grapple, lift the load slightly and make sure that the load is secure. If the load appears to be unstable, lower the load, open the grapple and reposition the load to attain full stability.**

**Reduce speed when driving over rough terrain, on a slope, or turning, to avoid overturning the vehicle.**

**Avoid side slope travel whenever possible. Drive up the slope to pick up a load and then down in reverse. Carry loads as close to the ground as possible.**

**Before exiting the prime mover, lower the bucket to the ground, turn off the prime mover's engine, remove the key and apply the brakes.**

**Do not detach loader from tractor with this attachment installed. Equip loader with materials bucket when detaching.**

# MAINTENANCE



## KNOW YOUR EQUIPMENT

Know your equipment's capabilities, dimensions and operations before operating. Visually inspect your equipment before you start, and never operate equipment that is not in proper working order with all safety devices intact. Check all hardware to ensure it is tight. Make certain that all locking pins, latches, and connection devices are properly installed and secured. Remove and replace any damaged, fatigued, or excessively worn parts. Make certain all safety decals are in place and are legible. Keep decals clean, and replace them if they become worn and hard to read.

## BEFORE EACH USE

- Make sure that all nuts and bolts are in place and properly tightened.
- Make sure that all other fasteners are in place and are performing their specified function.
- Make sure that all safety signs are in place, are clean, and are legible.
- Replace any damaged parts and excessively worn parts.

**IMPORTANT: When replacing parts, use only factory approved replacement parts. Manufacturer will not claim responsibility for use of unapproved parts or accessories and/or other damages as a result of their use.**

## LUBRICATION

The only lubrication your attachment may need is the greasing of the cylinder ends and pivot points. A grease fitting has been installed to facilitate this task. We recommend greasing all grease fittings after the initial 8 hours of operation and then every 40 hours of operation thereafter.

## DAILY OR EVERY 8 HOURS OF OPERATION

Replace any missing bolts or nuts with approved replacement parts.  
Check hydraulic system for leaks. (If so equipped.)  
Visually inspect the machine for worn parts or cracked welds. Repair as necessary.  
Replace any damaged, illegible or missing decals.

# SERVICE

## WARNING! DO NOT MODIFY MACHINE OR ATTACHMENTS



Modifications may weaken the integrity of the and may impair the function, safety, life, and performance of the . When making repairs, use only the manufacturer's genuine parts, following authorized instructions. Other parts may be substandard in fit and quality. Never modify any ROPS (Roll Over Protection Structure) or FOPS (Falling Object Protective Structure) equipment or device. Any modifications must be authorized in writing by the manufacturer.

# MANURE FORK GRAPPLE PARTS ILLUSTRATION

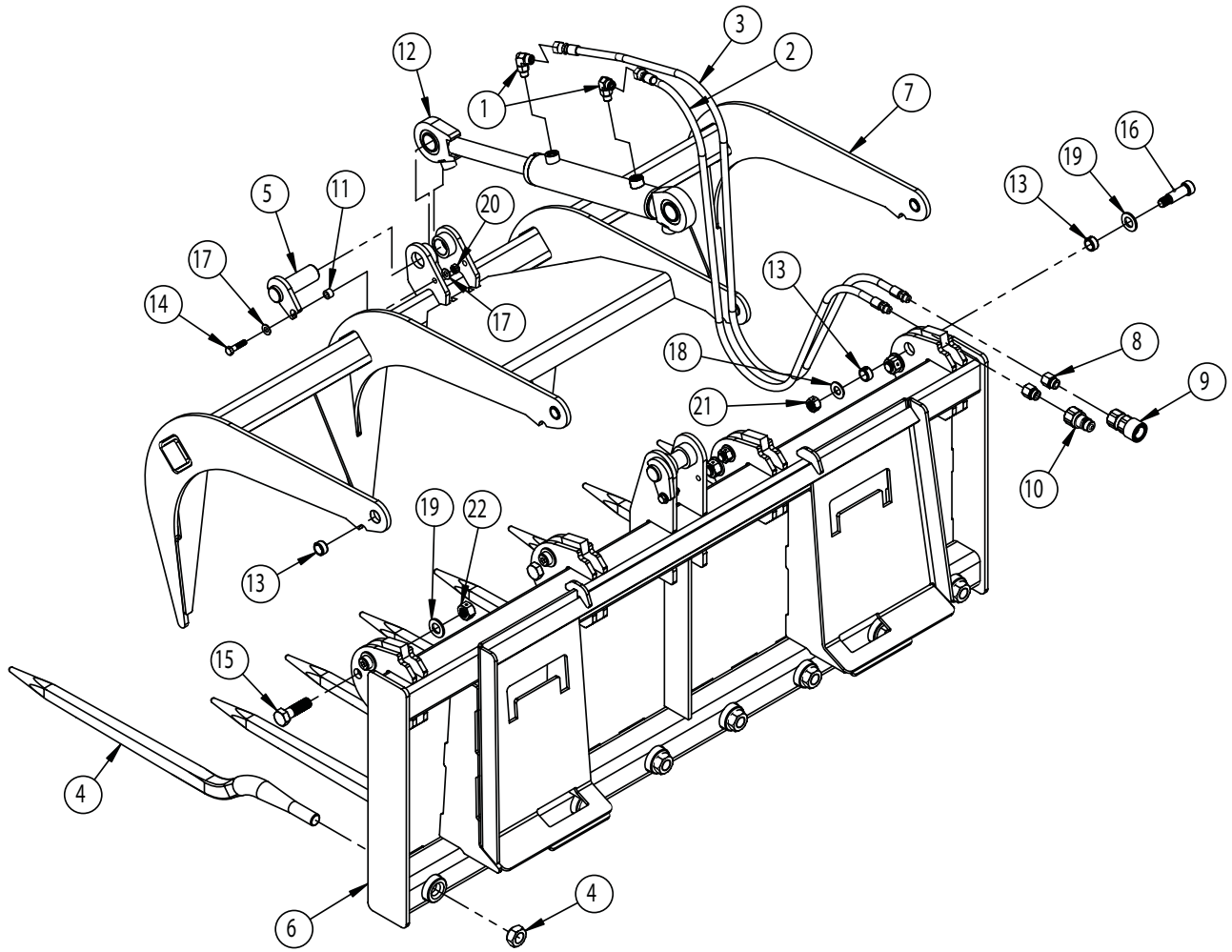

## MANURE FORK GRAPPLE PARTS LIST

ITEM	QTY.	10708-60	10708-72	10708-84	10708-96	DESCRIPTION
1	2				03-10079	90° Elbow 6MB-6MF
2	1				03-10124	Hose .25 x 72" 6FF-6MB Sheathed
3	1				03-10125	Hose .25 x 81" 6FF-6MB Sheathed
4	varies	(8)	(9)	(10)	(12) 07-10157	Tine Cranked Conus I w/ M24 Nut
5	2				13-52369	Pivot Pin Weldment 3.47"
6	1	13-52550	13-52551	13-52552	13-52553	Main Frame Weldment
7	1				13-52577	Grapple Weldment
*8	2				3338	Adaptor 6FB-8MB
*9	1				17139	QD Male 8FBO PP .50 BODY
*10	1				17140	QD Female 8FBO PP .50 BODY
11	2				81595	Tube Rnd .62 x .385 x .44 YDC
12	1				107865	Hydraulic Cylinder 2 x 8.5 x 1.25 3000psi
13	12				LAF9481	Connex Spring Bushing 1.00 OD X 0.75 ID X 0.50 No Holes or Grooves
14	2				RHW1209	Grade 5 Hex Head Cap Screw .38" x 1.5"
15	4				RHW1707	Grade 5 Hex Head Cap Screw .75" x 2.5"
16	4				RHW4103	Allen Head Shoulder Screw: .75" x 1.75" (.63" dia.x .88" threads)
17	4				RHW5232	Grade 5 Flat Washer SAE .38"
18	4				RHW5632	Grade 5 Flat Washer SAE .63"
19	8				RHW5732	Grade 5 Flat Washer SAE .75"
20	2				RHW7203	Grade 5 Center Dent Lock Nut .38"
21	4				RHW7603	Grade 5 Center Dent Lock Nut .63"
22	4				RHW7703	Grade 5 Center Dent Lock Nut .75"

NOTE: All parts are the same as 10708-96 except for those parts numbered under the other models.

\*ITEM may vary per tractor/loader -- Contact FFC for correct item.



**PALADIN LIGHT CONSTRUCTION**

**Warranty Registration Form and Delivery Inspection Report**

**IMPORTANT!** Warranty **Void** if card is not returned with 10 days.  
All Applicable sections **must** be filled in.

*This section to be filled out and signed by Dealer at time of delivery.*

**Warranty Registration**

Customer's Name _____	Dealer's Name _____
Address _____	Address _____
City _____ State _____ Zip _____	City _____ State _____ Zip _____
Phone _____	<b>CHECK ONE:</b>
Loader / Tractor Model _____	Construction Use _____
Delivery Date _____	Agricultural Use _____
Model or Part # _____	Landscape Use _____
Serial # _____	Other: _____

**Dealer Inspection** (check items applicable)

- |   |   |
|---|---|
| <input type="checkbox"/> All Decals installed (see operator's manual) | <input type="checkbox"/> Review Operating and Safety Instructions |
| <input type="checkbox"/> Hydraulic fittings tight and free of leaks   | <input type="checkbox"/> Guards and covers in place and secure    |
| <input type="checkbox"/> Fasteners tight                              | <input type="checkbox"/> Does Product Function Properly           |

I have thoroughly instructed the buyer on the above described equipment. This review included: The Operator's manual content, equipment care, adjustments, safe operation and applicable warranty policy.

Date \_\_\_\_\_ Dealer's Rep. signature \_\_\_\_\_

*This section to be completed and signed by the customer*

	1 Excellent	2 Good	3 Average	4 Unsatisfactory	5 Poor
<b>QUALITY ASSURANCE RATING</b>					
<b>Question:</b>		<b>FFC</b>		<b>Local Dealer</b>	
Quality of Product: Appearance .....		_____			
Construction .....		_____			
Quality of Service .....		_____		_____	
Value (Priced Fairly) .....		_____		_____	
Does it perform as claimed .....		_____			

The above described equipment and Operator's Manual have been received by me and I have been thoroughly instructed as to care, adjustments, safe operation and applicable warranty policy.

Date: \_\_\_\_\_ Owner's signature \_\_\_\_\_

**NOTE! Make one copy each for the dealer's and owner's records. Mail original to FFC Attachments.**



**PALADIN LIGHT CONSTRUCTION**

### **FFC LIMITED 12 MONTH WARRANTY**

Thank you for purchasing a FFC product. Warranty protection is valid only when this Warranty Registration is completed and signed by the customer and dealer, and mailed to FFC. I hereby acknowledge that I have received a copy of the owners Limited Warranty and I accept the terms therein.

For a period of 12 months from date of delivery of product to the original user, FFC, warrants each product to be free from manufacturing defects, subject to the limitations contained in this policy.

This warranty does not apply to defect caused, in whole or in part, by unreasonable use while in the possession of the user, including, but not limited to: failure to properly set up product; failure to provide reasonable and necessary maintenance; normal wear; routine tune ups or adjustments; improper handling or accidents; operation at speed or load conditions contrary to published specification; improper or insufficient lubrication; improper storage. This warranty is also not a guarantee that the performance of each product will meet the expectations of the purchaser.

FFC shall not be liable for consequential damages of any kind, including, but not limited to: consequential labor costs or transportation charges in connection with the replacement or repair of defective parts; lost time or expense which may have accrued because of said defects. In no event shall FFC, Inc.'s total liability hereunder exceed the product purchase price.

FFC makes no warranty with respect to trade accessories or any component or accessory of the product which was not manufactured by FFC, including any purchased components on any kind. These are subject to the warranties of their respective manufacturers. The warranty will be considered void if the product or any part of the product is modified or repaired in any way not expressly authorized by FFC, or if closed components are disassembled prior to return. Closed components include, but are not limited to: gearboxes, hydraulic pumps, motors, cylinders, and actuators.

Our obligation under the warranty is expressly limited, at our option, to the replacement or repair at FFC, of Lee, Illinois, or at a service facility designated by us, or such part or parts as inspection shall disclosed to have been defective. We are not responsible for unauthorized repairs or replacements. Any implied or statutory warranties, including any warranty of merchantability or fitness for a particular purpose, are expressly limited to the duration of this written warranty. We make no other express or implied warranty, nor is anyone authorized to make any in our behalf. This warranty cannot be extended, broadened, or changed except in writing by an authorized officer of FFC.