

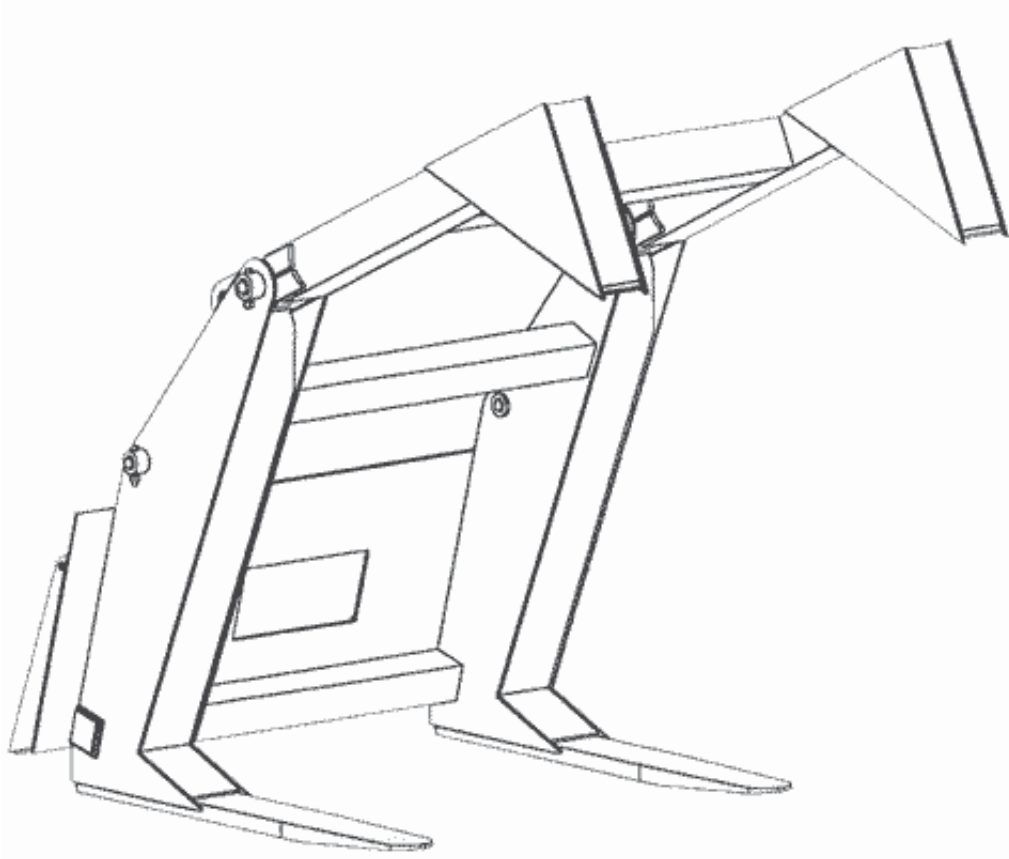

PALADIN LIGHT CONSTRUCTION

LOG GRAPPLE



SERIAL NUMBER: _____

MODEL NUMBER: _____

Manual Number: MR15533

Model Covered: LAF1142

Date: February 13, 2006

TO THE OWNER AND OPERATOR

Model: LAF1142

Provide this information to your dealer to obtain correct repair parts.

Throughout this manual, the terms **IMPORTANT**, **CAUTION**, **WARNING** and **DANGER** are used to indicate the degree of hazard for items of personal safety. These words will be used in conjunction with the Safety-Alert-Symbol, a triangle with an exclamation mark.



The Safety-Alert-Symbol means:

ATTENTION! BECOME ALERT! YOUR SAFETY IS INVOLVED!



DANGER Indicates an imminently hazardous situation which, if not avoided, **WILL result in death or serious injury.**



WARNING Indicates a potentially hazardous situation which, if not avoided, **COULD result in death or serious injury.**



CAUTION Indicates a potentially hazardous situation which, if not avoided, may result in minor or moderate injury, or to direct attention to unsafe practices which could result in personal injury.

IMPORTANT OR NOTICE Indicate that failure to observe can cause damage to equipment.

ACCIDENTS CAN BE PREVENTED WITH YOUR HELP

No accident prevention program can be successful without the wholehearted cooperation of the person who is directly responsible for the operation of the equipment.

To read accident reports from all over the country is to be convinced that a large number of accidents can be prevented only by the operators anticipating the result before the accident occurs, and doing something to prevent it. No power-driven equipment, whether it is on the highway, in the harvest field, or in an industrial plant, can be any safer than the person who is at the controls.

If accidents are to be prevented, and they can be prevented, it will be done by the operators who accept a full measure of their responsibility.

It is true that the designer, the manufacturer and the safety engineer can help; and they do help, but their combined efforts can be wiped out by a single careless act of the operator.

The best kind of a safety device is a careful operator. We ask you to be that kind of an operator.

YOU ARE THE KEY WORD TO SAFETY AS:

- YOU are responsible for the SAFE operation and maintenance of your Log Grapple.
- YOU are responsible to familiarize yourself and anyone else who will operate, maintain, assemble or work around this attachment, with the SAFETY information contained in this manual.
- YOU are responsible to read or translate ALL information contained in this manual to any English-illiterate operators or maintenance people, and to make certain that they have a complete and thorough understanding of the manual's contents. Translations of this manual into other languages are available upon request, contact FFC to order a translation.
- YOU can reduce the risk of injury or death by following all safety precautions and using good safety practices.

WORK SAFELY -- FOLLOW THESE RULES

A Careful Operator Is The Best Insurance Against Accidents



WARNING

Read and completely understand this manual before attempting assembly, operating, maintaining or working around this product.

TRAINING

Know your controls and how to stop tractor movement and engine quickly in an emergency. READ THIS MANUAL AND THE ONES PROVIDED WITH YOUR LOADER, AND TRACTOR. READ ALL SAFETY DECALS ON THE LOG GRAPPLE, LOADER AND TRACTOR.

To avoid accident and injury, do not allow anyone to operate or maintain this equipment without proper instructions. Any person who operates this equipment must be instructed in and be capable of the safe operation of the Log Grapple, Loader, Tractor and all controls.

Carefully supervise inexperienced operators from a safe distance.

MOUNTING SAFETY



WARNING

Always make certain that all locking pins and/or latches are properly installed and/or latched before operating machinery.

- The Log Grapple must fit onto the loader the same as the original bucket fit, either quick-attach, pin connection or as intended by the loader manufacturer. If the Log Grapple does not fit properly, contact FFC before operating.
- Follow good shop practices:
 - Keep area clean and dry.
 - Use properly grounded electrical outlets and tools.
 - Use adequate light.
 - Use the right tool for the job at hand.
- Work on a flat level surface.
- Wear appropriate protective equipment, ie: hard hat, safety glasses, work gloves, work boots, etc.



OPERATING SAFETY

DANGER

DO NOT USE THE LOG GRAPPLE TO LIFT ROUND BALES.



DANGER

**GRAPPLE MOVES QUICKLY!
Do not stand near or place extremities near grapple or between grapple and implement.**

- Never leave equipment unattended with engine running or with loader arms raised.
- Always lower Log Grapple close to ground, close grapple, set parking brake, stop engine and wait for all moving parts to stop before adjusting the forks.
- Make certain that forks are completely under the load before lifting.
- Keep load level at all times.
- Do not place any part of your body under load or forks at any time.
- Do not stand or climb on raised forks.
- Keep loads close to ground while transporting.
- Do not use the Log Grapple until you have read the operator's manual supplied with your loader for detailed operating, maintenance and safety precautions.
- Keep hands, feet, clothing and hair away from all moving parts.
- Do not operate equipment while under the influence of drugs or alcohol.
- Review safety instructions annually.
- Never allow anyone around tractor when in operation.
- Do not allow riders on the attachment or tractor.
- Be sure all connection points are properly secured.
- Never operate controls from the ground. Operate only from the operator's position.
- Do not use loader as a manlift. Never lift or transport any person(s) on forks, or load.
- Be sure you are on solid ground before lifting any load.
- Wear appropriate protective equipment, ie: hard hat, safety glasses, work gloves, work boots, etc.

WORK SAFELY -- FOLLOW THESE RULES A Careful Operator Is The Best Insurance Against Accidents

HYDRAULIC INSTALLATION

Two hydraulic hoses will be required to go from the auxiliary hydraulic on the loader arms to the "T" fittings on the Log Grapple. These hoses require #6 Female JIC fitting on one end, and quick disconnect or other proper fitting to fit into the auxiliary hydraulics on the loader at the other end.

Make certain that these hoses are long enough to extend, without stretching, from auxiliary hydraulics to the cylinder, while loader arms are at maximum height and at fully dumped position.

Make certain that hoses will not get pinched or tangled in the loader arms, forks or grapple.

HYDRAULIC SAFETY



WARNING

Escaping hydraulic fluid under pressure will cause serious injury if it penetrates the skin.

Get immediate medical attention if injured!
This type of injury may result in gangrene if left untreated.

- Use metal or wood to search for hydraulic leaks, **DO NOT USE YOUR HANDS.**
- Relieve hydraulic pressure before disconnecting hydraulic lines (refer to you loader's operator's manual for instructions on how to relieve hydraulic pressure in the lines).
- Inspection and maintenance of all hydraulic systems is required.
- Use only high pressure hydraulic hoses and fittings as specified by loader manufacturer.

MAINTENANCE



WARNING

Do not remove the grapple. Falling load may result in death or serious injury.

- Before operating
 - Make sure that all grapple pivot pins and cylinder connection pins are securely fastened, lubricated and in good operating condition.
 - Grease all eight lubrication points, (as indicated by item #10 in parts illustration, pg. 8), before initial use of grapple and after every ten hours of use. Failure to do so will cause excessive wear of pivot pins and could lead to pin failure.
- Before servicing or cleaning -- lower attachment to ground, close grapple and shut off engine.
- Make no modifications to the attachment, do not repair with any parts other than original FFC parts.

SAFETY DECAL LOCATIONS

ITEM	QTY	PART #	DESCRIPTION
1	1	RDL3139	Instructions
2	1	50-0723	Read Manual
3	1	50-0724	Hydraulic Leaks
4	1	RDL3103	Falling Load
5	2	50-0737	Pinch Point
6	2	RDL3125	Keep Clear

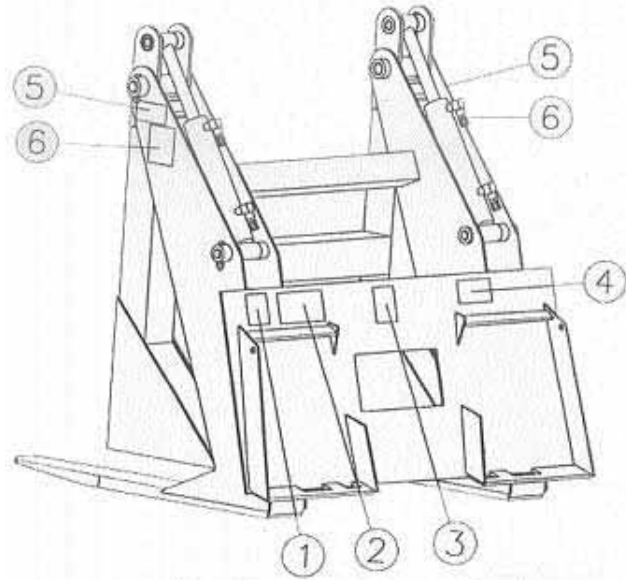

1. Always keep decals clean and legible.
2. Replace decals if they are illegible or missing.
3. Parts replacing decalated parts should also be decalated.
4. Decals are available, free of charge, from your dealer's parts department or from FFC.

TO PLACE OR REPLACE DECALS

1. Clean area with non-flammable solvent, then wash with soap and water.
2. Allow to dry.
3. Apply pressure sensitive decals and smooth out.



ITEM 1

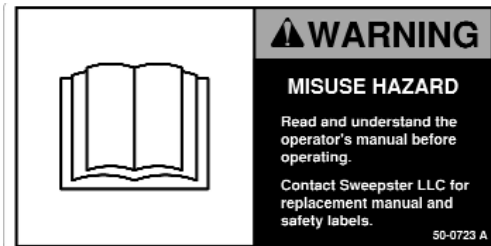

ITEM 2



ITEM 3

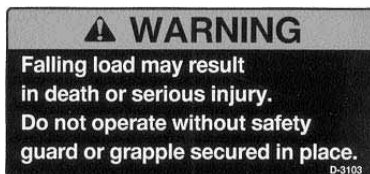

ITEM 4



ITEM 5



ITEM 6

OPERATING

POSITIONING

- Be aware of how the load's weight is distributed.
- Open grapple.
- Always make certain that forks are completely under the load before lifting.
- For well balanced loads:
 - Position forks so that the load is centered on the forks.
 - Close grapple.
- For unbalanced loads:
 - Position forks so that the heavy side of the load is toward the Log Grapple's main frame, (closest to the machine).
 - Close grapple.
- For wide loads:
 - Position forks under area which will balance the load.
 - Close grapple.

LIFTING



WARNING

Falling debris may result in death or serious injury. Do not lift any load that cannot be safely secured by the grapple.



WARNING

Do not lift any load while bystanders are near, keep other people away while operating equipment.

- Be sure you are on solid ground.
- Always lift load slightly to be sure load is secure. If the load appears to be unstable, lower forks, open grapple and reposition forks to achieve best stability.

TRANSPORTING

- Always make sure that the load is well balanced and secure before transporting.
- Be aware of, and avoid, any obstacles, bumps or holes in your intended path.
- Keep load close to the ground.
- Do not make sharp turns.
- Slow down before making any turn.
- Accelerate and brake gradually.
- Check the load frequently to be sure it remains stable and balanced.

PARTS LIST AND ILLUSTRATION

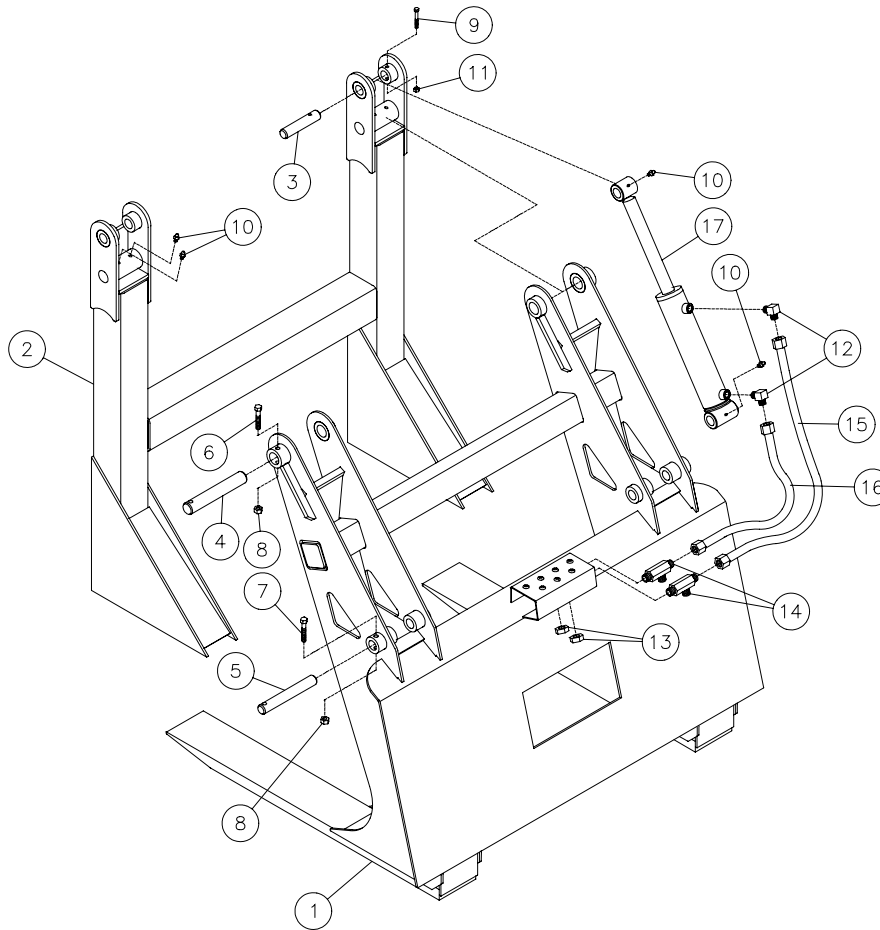

ITEM #	QTY	PART #	DESCRIPTION
1	1	LAF1160	Main Frame Weldment
2	1	LAF1161	Grapple Weldment
3	2	LAF3100	Upper Cylinder Pin
4	2	LAF3098	Grapple Pivot Pin
5	2	LAF3099	Lower Cylinder Pin
6	2	RHW1213	3/8" x 2-1/2" Hex Bolt Gr5
7	2	RHW1212	3/8" x 2-1/4" Hex Bolt Gr5
8	4	RHW7203	3/8" Center Dent Locknut Gr5
9	2	RHW1041	1/4" x 2" Hex Bolt Gr8
10	8	RHW8090	Screw Zerk .25-28tpi Self Tap
11	2	RHW7003	1/4" Center Dent Locknut Gr5
12	4	LAF4298	Fitting 90 Degree 6MB-6MJ
13	2	LAF4098	#6 Bulkhead Jam Nut .56-18
14	2	LAF4097	Bulkhead Branch Tee 6MJ w/o Nut
15	2	LAF4329	Hose .38-6FJ-6FJ-32.0
16	2	LAF4330	Hose .38-6FJ-6FJ-22.0
17	2	LAF4606	Hyd. Cylinder 2.0-8-1.25 Perpend. 4000-psi

When ordering replacement hose, measure old hose and specify total length needed (including fittings).

See safety decal page for safety decal information.



PALADIN LIGHT CONSTRUCTION

Warranty Registration Form and Delivery Inspection Report

IMPORTANT! Warranty **Void** if card is not returned with 10 days.
All Applicable sections **must** be filled in.

This section to be filled out and signed by Dealer at time of delivery.

Warranty Registration

Customer's Name _____	Dealer's Name _____
Address _____	Address _____
City _____ State _____ Zip _____	City _____ State _____ Zip _____
Phone _____	CHECK ONE:
Loader / Tractor Model _____	Construction Use _____
Delivery Date _____	Agricultural Use _____
Model or Part # _____	Landscape Use _____
Serial # _____	Other: _____

Dealer Inspection (check items applicable)

- | | |
|---|---|
| <input type="checkbox"/> All Decals installed (see operator's manual) | <input type="checkbox"/> Review Operating and Safety Instructions |
| <input type="checkbox"/> Hydraulic fittings tight and free of leaks | <input type="checkbox"/> Guards and covers in place and secure |
| <input type="checkbox"/> Fasteners tight | <input type="checkbox"/> Does Product Function Properly |

I have thoroughly instructed the buyer on the above described equipment. This review included: The Operator's manual content, equipment care, adjustments, safe operation and applicable warranty policy.

Date _____ Dealer's Rep. signature _____

This section to be completed and signed by the customer

	1 Excellent	2 Good	3 Average	4 Unsatisfactory	5 Poor
QUALITY ASSURANCE RATING					
Question:		FFC		Local Dealer	
Quality of Product: Appearance		_____		_____	
Construction		_____		_____	
Quality of Service		_____		_____	
Value (Priced Fairly)		_____		_____	
Does it perform as claimed		_____		_____	

The above described equipment and Operator's Manual have been received by me and I have been thoroughly instructed as to care, adjustments, safe operation and applicable warranty policy.

Date: _____ Owner's signature _____

NOTE! Make one copy each for the dealer's and owner's records. Mail original to FFC Attachments.



PALADIN LIGHT CONSTRUCTION

FFC LIMITED 12 MONTH WARRANTY

Thank you for purchasing a FFC product. Warranty protection is valid only when this Warranty Registration is completed and signed by the customer and dealer, and mailed to FFC. I hereby acknowledge that I have received a copy of the owners Limited Warranty and I accept the terms therein.

For a period of 12 months from date of delivery of product to the original user, FFC, warrants each product to be free from manufacturing defects, subject to the limitations contained in this policy.

This warranty does not apply to defect caused, in whole or in part, by unreasonable use while in the possession of the user, including, but not limited to: failure to properly set up product; failure to provide reasonable and necessary maintenance; normal wear; routine tune ups or adjustments; improper handling or accidents; operation at speed or load conditions contrary to published specification; improper or insufficient lubrication; improper storage. This warranty is also not a guarantee that the performance of each product will meet the expectations of the purchaser.

FFC shall not be liable for consequential damages of any kind, including, but not limited to: consequential labor costs or transportation charges in connection with the replacement or repair of defective parts; lost time or expense which may have accrued because of said defects. In no event shall FFC, Inc.'s total liability hereunder exceed the product purchase price.

FFC makes no warranty with respect to trade accessories or any component or accessory of the product which was not manufactured by FFC, including any purchased components on any kind. These are subject to the warranties of their respective manufacturers. The warranty will be considered void if the product or any part of the product is modified or repaired in any way not expressly authorized by FFC, or if closed components are disassembled prior to return. Closed components include, but are not limited to: gearboxes, hydraulic pumps, motors, cylinders, and actuators.

Our obligation under the warranty is expressly limited, at our option, to the replacement or repair at FFC, of Lee, Illinois, or at a service facility designated by us, or such part or parts as inspection shall disclosed to have been defective. We are not responsible for unauthorized repairs or replacements. Any implied or statutory warranties, including any warranty of merchantability or fitness for a particular purpose, are expressly limited to the duration of this written warranty. We make no other express or implied warranty, nor is anyone authorized to make any in our behalf. This warranty cannot be extended, broadened, or changed except in writing by an authorized officer of FFC.