

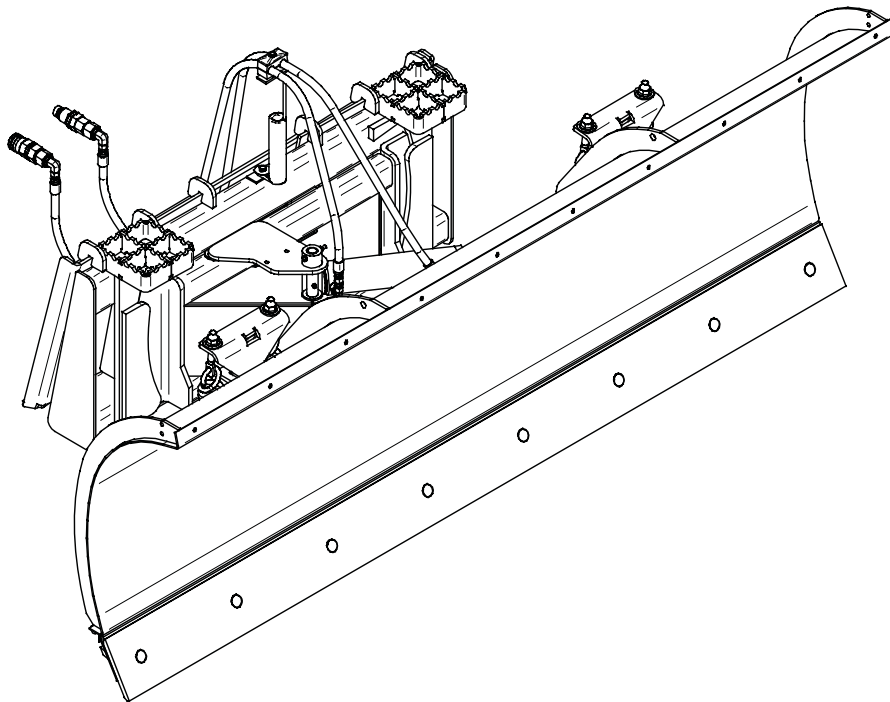

LIGHT MATERIAL / SNOW BLADE WITH TRIP EDGE



PALADIN LIGHT CONSTRUCTION



SERIAL NUMBER: _____

MODEL NUMBER: _____

Manual Number: 51-10024
Models: 11672, 11690, 11602,
11619 & Optional Kits
Date: August 2007

TABLE OF CONTENTS

Introduction, General Information, Serial Number	1
Owner and Operator Safety Information	2-5
Definitions of Safety Terms and Symbols, Accident Prevention	2
Safety Instructions	3-4
Safety Signs	5
Power Unit Specifications, Mounting	6
Hydraulic Connection	7
Setup	8
Operation	9
Maintenance	9
Service	10
Parts Illustrations	11
Parts Lists	12-15
Specifications	16
Warranty	i

INTRODUCTION

Congratulations on your purchase of a new FFC Snow Blade. This product has been designed and built to push snow forward only. In addition, light bulldozing may be performed (see SNOW BLADE OPERATION). You or any other person who will be assembling, operating, maintaining, or working with this product are required to read and completely understand the information and instructions contained in this manual. If anyone does not fully understand every part of this manual, please obtain further assistance by contacting the dealer from which this product was purchased or by contacting FFC at the telephone number or address listed on the cover of this manual. Keep this manual available for reference whenever this product is being handled or used. Provide this manual to any new owners and/or operators.

This manual covers model(s) 11672, 11690, 11602 and 11619.

GENERAL INFORMATION

The purpose of this manual is to assist in assembling, mounting, operating, and maintaining your Snow Blade. Read this manual carefully to obtain valuable information and instructions that will help you achieve years of safe and dependable service.

The illustrations and data used in this manual were current at the time of printing, but due to possible engineering and/or production changes, this product may vary slightly in detail. FFC reserves the right to redesign and/or change components as may be necessary without notification to anyone.

Throughout this manual, references may be made to:

Power Unit	The engine-driven machine to which this product must be attached.
Right, Left, Front, Rear	Directions that are determined in relation to the operator of the equipment when seated in the normal operating position
IMPORTANT	Precautions that must be followed to prevent damage to equipment.
NOTICE	Precautions that must be followed to prevent substandard performance.

SERIAL NUMBER LOCATION

Always refer to the model and serial number when ordering parts or requesting information from your dealer. The serial number plate for this product is located on the top left surface of the loader attachment plate of your Snow Blade.

Reference Information	
Model Number	Loader Make
Serial Number	Loader Model
Date Purchased	Loader Serial Number

SAFETY STATEMENTS

DANGER



THIS STATEMENT IS USED WHERE SERIOUS INJURY OR DEATH WILL RESULT IF THE INSTRUCTIONS ARE NOT FOLLOWED PROPERLY.

WARNING



THIS STATEMENT IS USED WHERE SERIOUS INJURY OR DEATH COULD RESULT IF THE INSTRUCTIONS ARE NOT FOLLOWED PROPERLY.

CAUTION



THIS STATEMENT IS USED WHERE MINOR INJURY COULD RESULT IF THE INSTRUCTIONS ARE NOT FOLLOWED PROPERLY.

CAUTION

THIS STATEMENT IS USED WHERE EQUIPMENT OR PROPERTY DAMAGE COULD RESULT IF THE INSTRUCTIONS ARE NOT FOLLOWED PROPERLY.



THIS SYMBOL BY ITSELF OR USED WITH A SAFETY SIGNAL WORD THROUGHOUT THIS MANUAL IS USED TO CALL YOUR ATTENTION TO INSTRUCTIONS INVOLVING YOUR PERSONAL SAFETY OR THE SAFETY OF OTHERS. FAILURE TO FOLLOW THESE INSTRUCTIONS CAN RESULT IN INJURY OR DEATH.

SAFETY PRECAUTIONS GENERAL SAFETY PRECAUTIONS

WARNING



READ MANUAL PRIOR TO INSTALL

Improper installation, operation, or maintenance of this equipment could result in serious injury or death. Operators and maintenance personnel should read this manual as well as all manuals related to this equipment and the prime mover thoroughly before beginning installation, operation, or maintenance. **FOLLOW ALL SAFETY INSTRUCTIONS IN THIS MANUAL AND THE PRIME MOVERS MANUAL.**

WARNING



READ AND UNDERSTAND ALL SAFETY STATEMENTS

Read all safety decals and safety statements in all manuals prior to operating or working on this equipment. Know and obey all OSHA regulations, local laws and other professional guidelines for your operation. Know and follow good work practices when assembling, maintaining, repairing, mounting, removing or operating this equipment.



KNOW YOUR EQUIPMENT

Know your equipment's capabilities, dimensions and operations before operating. Visually inspect your equipment before you start, and never operate equipment that is not in proper working order with all safety devices intact. Check all hardware to assure it is tight. Make certain that all locking pins, latches, and connection devices are properly installed and secured. Remove and replace any damaged, fatigued or excessively worn parts. Make certain all safety decals are in place and are legible. Keep decals clean, and replace them if they become worn and hard to read.

GENERAL SAFETY PRECAUTIONS - CONTINUED

WARNING PROTECT AGAINST FLYING DEBRIS



Always wear proper safety glasses, goggles or a face shield when driving pins in or out or when any operation causes dust, flying debris, or any other hazardous material.

WARNING LOWER OR SUPPORT RAISED EQUIPMENT



Do not work under raised booms without supporting them. Do not use support material made of concrete blocks, logs, buckets, barrels or any other material that could suddenly collapse or shift positions. Make sure support material is solid, not decayed, warped, twisted, or tapered. Lower booms to ground level or onto blocks. Lower booms and attachments to the ground before leaving the cab or operator's station.

WARNING USE CARE WITH HYDRAULIC FLUID PRESSURE



Hydraulic fluid under pressure can penetrate the skin and cause serious injury or death. Hydraulic leaks under pressure may not be visible. Before connecting or disconnecting hydraulic hoses, read your prime movers operator's manual for detailed instructions on connecting and disconnecting hydraulic hoses or fittings.

- Keep unprotected body parts, such as face, eyes, and arms as far away as possible from a suspected leak. Flesh injected with hydraulic fluid may develop gangrene or other permanent disabilities.
- If injured by injected fluid, see a doctor at once. If your doctor is not familiar with this type of injury, ask him to research immediately to determine proper treatment.
- Wear safety glasses, protective clothing, and use a sound piece of cardboard or wood when searching for hydraulic leaks. **DO NOT USE YOUR HANDS!** SEE ILLUSTRATION.

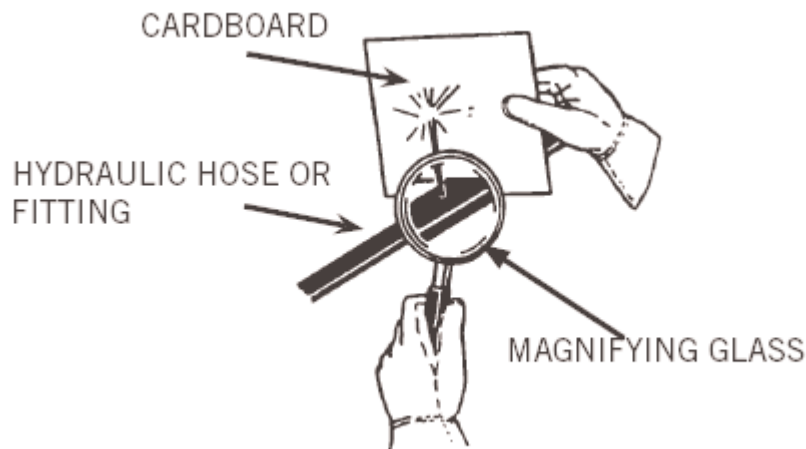

GENERAL SAFETY PRECAUTIONS - CONTINUED

WARNING DO NOT MODIFY MACHINE OR ATTACHMENTS



Modifications may weaken the integrity of the attachment and may impair the function, safety, life and performance of the attachment. When making repairs, use only the manufacturer's genuine parts, following authorized instructions. Other parts may be substandard in fit and quality. Never modify any ROPS (Roll Over Protection System) equipment or device. Any modifications must be authorized in writing by the manufacturer.

WARNING SAFELY MAINTAIN AND REPAIR EQUIPMENT



- Do not wear loose clothing, or any accessories that can catch in moving parts. If you have long hair, cover or secure it so that it does not become entangled in the equipment.
- Work on a level surface in a well-lit area.
- Use properly grounded electrical outlets and tools.
- Use the correct tool for the job at hand. Make sure they are in good condition for the task required.
- Wear the protective equipment specified by the tool manufacturer.

WARNING SAFELY OPERATE EQUIPMENT



- Do not operate equipment until you are completely trained by a qualified operator in how to use the controls, know its capabilities, dimensions, and all safety requirements. See your prime movers manual for these instructions.
- Keep all step plates, grab bars, pedals, and controls free of dirt, grease, debris, and oil.
 - Never allow anyone to be around the equipment when it is operating.
 - Do not allow riders on the attachment or the prime mover.
 - Do not operate the equipment from anywhere other than the correct operators position.
 - Never leave equipment unattended with the engine running or with this attachment in a raised position.
 - Do not alter or remove any safety feature from the prime mover or this attachment.
 - Know your work site safety rules as well as traffic rules and flow. When in doubt on any safety issue, contact your supervisor or safety coordinator for an explanation.

SAFETY SIGN LOCATIONS

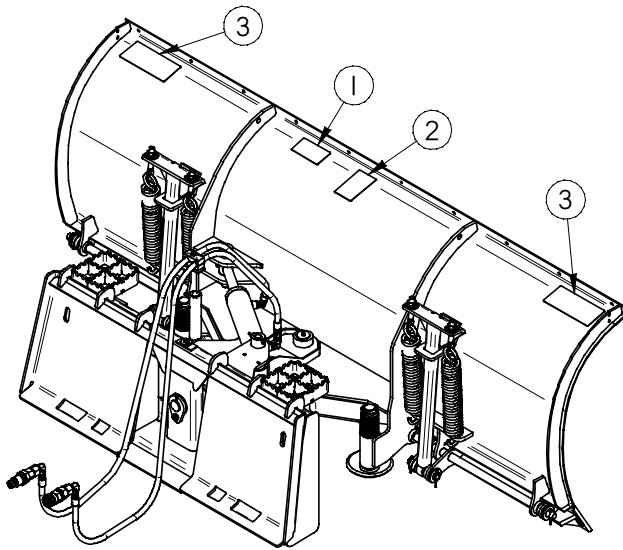

ITEM	QTY.	PART #	DESCRIPTION
1	1	50-10017	Read Manual
2	1	50-0724	Hydraulics
3	2	50-0721	Crush Hazard

INSTRUCTIONS

- Keep all safety signs clean and legible.
- Replace all missing, illegible, or damaged safety signs.
- Replacement parts for parts with safety signs attached must also have safety signs attached.
- Safety signs are available, free of charge, from your dealer or from FFC.

PLACEMENT OR REPLACEMENT OF SAFETY SIGNS

1. Clean the area of application with non-flammable solvent, and then wash the same area with soap and water.
2. Allow the surface to fully dry.
3. Remove the backing from the safety sign, exposing the adhesive surface.
4. Apply the safety sign to the position shown in the diagram above and smooth out any bubbles.

ITEM 1

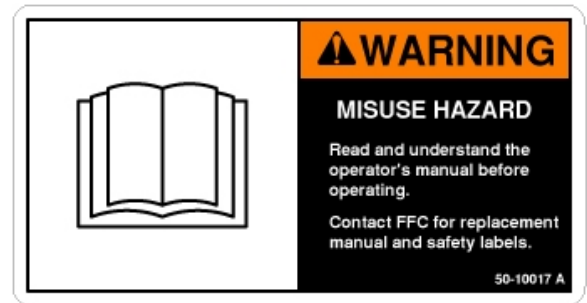

ITEM 2



ITEM 3

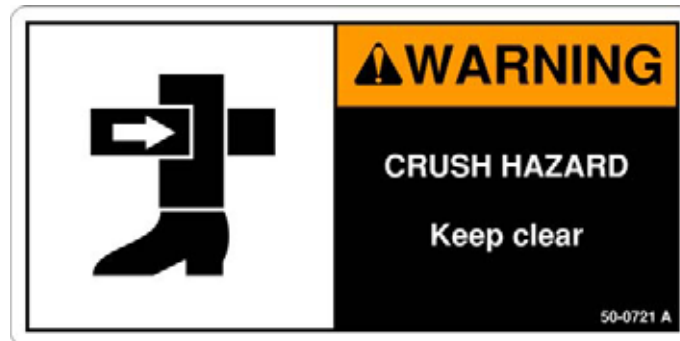

POWER UNIT SPECIFICATIONS

IMPORTANT Exceeding any of the maximum recommended power unit specifications **CAN** result in damage to this product and **WILL** void all FFC warranties.

DESCRIPTION	SPECIFICATIONS
	11600 Series
Weight of Power Unit Without Snow Blade	11,000 lbs. maximum
Hydraulic Pressure Output	3,500 psi. maximum
Rear Ballast	As required to maintain full product stability. (Note the Shipping Weight on the specifications page, then see the operator's manual(s) for your power unit, loader, and quick-attach for ballasting needs.)

SNOW BLADE MOUNTING



SAFETY FIRST! READ AND UNDERSTAND THE SAFETY INSTRUCTIONS (pages 2-5 of this manual) BEFORE BEGINNING ANY SNOW BLADE MOUNTING

1. Place this product on a firm, level surface that is large enough to safely accommodate this product, your power unit and all workers involved in the mounting process.
2. Refer to the operator's manual(s) for your power unit, loader, and quick-attach and follow the mounting instructions contained therein.

IMPORTANT Lubricate all grease fittings before connecting this product to your power unit's hydraulic system. Refer to SNOW BLADE MAINTENANCE page and follow the instructions.

SNOW BLADE HYDRAULIC CONNECTION



SAFETY FIRST! READ AND UNDERSTAND THE SAFETY INSTRUCTIONS (pages 2-5 of this manual) BEFORE BEGINNING ANY SNOW BLADE HYDRAULIC CONNECTION

1. You must purchase and install two hydraulic hoses that have fittings permanently attached to each end. These hoses and fittings must meet the following specifications: (NOTE: If your Snow Blade was supplied with hoses, skip to step 4.)
 - Inside Diameter:..... 0.375" (3/8")
 - Minimum Operating Pressure:..... 4,000 psi.
 - Hose End Fittings:..... One hose end must be a #6 female JIC fitting. The fitting for the other end can be whatever you determine to be the most beneficial to making the connection to your power unit.
 - Length:..... You must make this determination based upon recommendations provided in your power unit's operator's manual. The hoses must be long enough to avoid applying any tension to them (i.e. stretching) in all operating positions of this product. The hoses must not be excessively long either, because this could cause the hoses to drag on the ground, be pinched in the equipment, become entangled in moving parts, etc., any of which will shorten the life of the hose and could cause injury to the operator or others near the equipment.
2. Remove all the protective plastic caps from the hose ends and this product's connection fittings.
3. Make certain that the male and female threads, as well as the inside of the hoses, are clean, then place the #6 hose ends on/in to the fittings on this product and tighten to 21 ft. lbs., + or - 1.0 ft. lbs. (#6 is 9/16" dia. with 18 tpi.)
4. Make the connection to your power unit using the appropriate method below for your power unit:
 - If your power unit has male or female threads for connecting the hydraulic hoses to the auxiliary hydraulic lines, make certain that the threads, as well as the inside of the fittings and hoses, are clean, then secure the hoses to the fittings using the torque specified in your power unit's operator's manual.
 - If your power unit has quick-couplers for connecting the hydraulic hoses to the auxiliary hydraulic lines, you may need to purchase the proper quick-coupler fittings that you must install on the free ends of the two hoses. In most cases, the owner's manual for your power unit will describe the exact type of fitting that is needed for your hydraulic coupling system, but in no case should any fitting have an allowable operating pressure of less than 4,000 psi. Once all the quick-coupler fittings are properly installed, then the hoses can be coupled to the power unit's hydraulic valve body or auxiliary hydraulic lines as per the instructions found in your power unit's operator's manual.
5. Carefully raise the loader and cycle the tilt cylinders to check hose clearances and to check for any interference. Operate the hydraulic cylinder on this product to make the same checks.
6. Cycle the hydraulic cylinder on this product several times from fully retracted to fully extended until all air has been completely removed from the cylinder.



WARNING

Failure to obey this warning could result in death or serious injury.

Do not lock the auxiliary hydraulics of your power unit in the "ON" position.

NOTICE: When shipped, the hydraulic cylinder on this product contained air or an air-fluid mixture. Failure to remove all the air from the hydraulic cylinder(s) can cause uneven, jerky cylinder movement when the hydraulic controls are being operated and unwanted cylinder movement when the controls are not being operated.

SNOW BLADE SETUP



SAFETY FIRST! READ AND UNDERSTAND THE SAFETY INSTRUCTIONS (pages 2-5 of this manual) BEFORE BEGINNING ANY SNOW BLADE SETUP

SPRING SETUP

1. Park your power unit on a level surface with this product properly attached.
2. Place your power unit's transmission in "Park" and engage the parking brake.
3. Lower this product onto the level surface.
4. Shut off your power unit's engine, remove the starter key, wait for all moving parts to come to a stop, and relieve all pressure in the hydraulic lines.
5. Make sure that the springs on your Snow Blade comply with the specifications listed in the appropriate table below.

RECOMMENDED SPRING SETUP LENGTHS				
Blade Width	6'	7-1/2'	8-1/2'	10'
Recommended Spring Setup Length*: (Max. Length Permitted: 15-1/8")	14-3/8"			

*NOTE: The "Spring Setup Length" is measured from the inside of one hook to the inside of the other hook. The relaxed length of a spring is 14".

6. Test operate your Snow Blade. If the edge trips too easily, perform the following steps as needed:
 - A. Repeat the preceding steps (1 through 4).
 - B. First, try tightening the spade (or eye) bolts to lengthen the springs.

IMPORTANT Lengthening the springs beyond the maximums listed in the "SPRING SETUP LENGTHS" table CAN result in damage to this product and WILL void all FFC warranties.

- C. Test operate your Snow Blade again. If the edge still trips too easily, then contact FFC.

INSTALLATION OF OPTIONAL RUBBER OR POLYURETHANE EDGES

1. Remove the standard wear edge as per steps 1 through 7 on the "SNOW BLADE SERVICE (REPLACEMENT OF WEAR EDGE)" page and set aside the wear edge and all bolts.
2. Insert the bolts provided with the rubber or polyurethane edge through the steel strip, the edge, and the base of the moldboard. Secure the bolts with the nuts provided.

SNOW BLADE OPERATION



SAFETY FIRST! READ AND UNDERSTAND THE SAFETY INSTRUCTIONS (pages 2-5 of this manual) BEFORE BEGINNING ANY SNOW BLADE OPERATION



WARNING

Failure to obey the following procedures could result in death or serious injury.

- Never lift this product above (a.) the operator's eye level or (b.) to a height where visibility is obstructed, whichever is lower.
- Do not exceed 15 miles per hour while operating.

IMPORTANT Striking solid objects hidden in snow OR pushing materials other than snow CAN result in damage to this product and WILL void all FFC warranties.

Before any snowfall, inspect the site where your Snow Blade is to be used. Locate any obstructions (i.e. curbs, sidewalks, parking bumpers, pipes, shrubs, fences, etc.) and any variations in elevation (i.e. retaining walls, slopes, holes, etc.) so that these elements can be avoided during the snow plowing operation.

This Snow Blade may be used for dozing light, loose materials.

IMPORTANT Dozing of undisturbed soil, heavy materials, or similar items CAN result in damage to this product and WILL void all FFC warranties.

SNOW BLADE MAINTENANCE



SAFETY FIRST! READ AND UNDERSTAND THE SAFETY INSTRUCTIONS (pages 2-5 of this manual) BEFORE BEGINNING ANY SNOW BLADE MAINTENANCE

BEFORE EACH USE

- Make sure that all nuts and bolts are in place and properly tightened.
- Make sure that all other fasteners are in place and are performing their specified function.
- Make sure that all hydraulic fittings are tightened and that there are no leaks in any fittings or hoses.
- Make sure that all safety signs are in place, are clean, and are legible. (SEE THE SAFETY SIGN SECTION)
- Replace any damaged parts and excessively worn parts.

AFTER EVERY 10 HOURS OF USE

- Grease all grease fittings: see Parts Illustrations and Parts Lists for reference.



**SAFETY FIRST! READ AND UNDERSTAND THE SAFETY INSTRUCTIONS
(pages 2-5 of this manual) BEFORE BEGINNING ANY SNOW BLADE SERVICE**

REPLACEMENT OF WEAR EDGE

1. Park your power unit on a level surface with this product properly attached.
2. Place your power unit's transmission in "Park" and engage the parking brake.
3. Lower this product onto blocking positioned immediately behind the moldboard. This blocking must be of sufficient height to hold the wear edge approximately 6" to 8" above the level surface.
4. Shut off your power unit's engine, remove the starter key, wait for all moving parts to come to a stop, and relieve all pressure in the hydraulic lines.
5. Loosen the nuts on all the wear edge bolts and remove all nuts and wear edge bolts except the bolts on each end of the wear edge.
6. While holding up the end of the wear edge, remove the nut and bolt from that end and allow that end to pivot down to the level surface.
7. Repeat step 6 for the other end of the wear edge. Properly dispose of the wear edge and all bolts and nuts. These edges are reversible and may be flipped top-to-bottom for reinstallation.
8. Reinstall a new wear edge by reversing the procedures in steps 7 through 5 and tightening. Tighten the nuts to 150 ft. lbs.

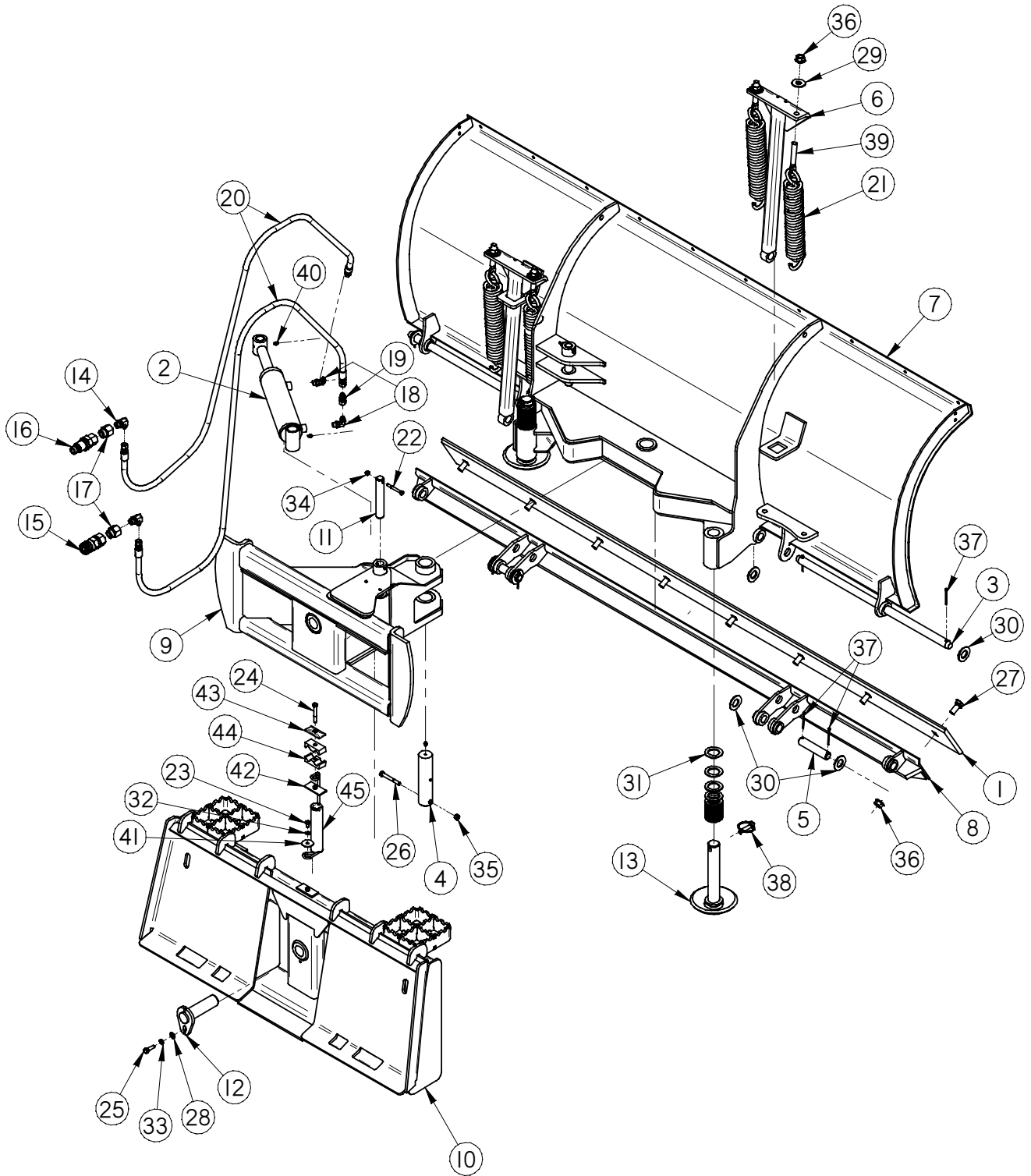

SNOW BLADE PARTS LIST: 11600 Series

ITEM	QTY.	6' 11672	7-1/2' 11690	8-1/2' 11602	10' 11619	DESCRIPTION
1	1	13-52843 (72")	102649 (90")	102650 (102")	13-52876 (119")	Wear Edge: 1/2 x 6 x length noted
2	1				102654	Hydraulic Cylinder: 2-1/2" piston, 8" stroke
3	2	13-52844 (20.69")	102657 (27.25")		102658 (33.25")	Rod: 1" x length noted w/ features
4	1				102665	Rod: 1-3/4" x 7-1/2" w/ features
5	2				102666	Rod: 1" x 5" w/ features
6	2				13-51846	Trip Spring Arm Weld
7	1	13-52859	13-51865	13-51864	13-52864	Moldboard Weld
8	1	13-52862	13-51866	13-51867	13-52867	Trip Edge Weld
9	1				13-51868	Swivel Mount Weld
10	1				13-51869	Main Frame Weld
11	2				13-51873	Rod: 1" x 6" w/ features
12	1				13-51875	Swivel Pin Weld
13	2				LAF1485	Skid Shoe Weld
14	2		Contact FFC to obtain the correct item			Hydraulic Elbow
15	1		Contact FFC to obtain the correct item			Hydraulic Coupler: Female
16	1		Contact FFC to obtain the correct item			Hydraulic Coupler: Male
17	2		Contact FFC to obtain the correct item			Hydraulic Adapter (not required for all models)
18	2				LAF4298	Hydraulic Elbow: 90°, 6MB – 6MJ
19	1				LAF4300	Hydraulic Fitting: Orifice, 6MJ – 6FJ, 5/8"
20	2		Contact FFC to obtain the correct item			Hydraulic Hose: 3/8" ID
21	4				LAF6405	Trip Spring
22	2				RHW1043	Grade 8 Hex Head Cap Screw: 1/4" x 2-1/2"
23	1				RHW1101	Grade 5 Hex Head Cap Screw: 5/16" x 1/2"
24	1				RHW1112	Grade 5 Hex Head Cap Screw: 5/16" x 2-1/2"
25	1				RHW1207	Grade 5 Hex Head Cap Screw: 3/8" x 3"
26	2				RHW1217	Grade 5 Hex Head Cap Screw: 3/8" x 3-1/4"
27	varies	(6)	(8)	(9)	(10) RHW2663	Grade 8 Plow Bolt: 5/8" x 1-3/4"
28	1				RHW5232	Grade 5 Flat Washer: 3/8" SAE
29	4				RHW5662	Grade 5 Flat Washer: 5/8" USS
30	8				RHW5932	Grade 8 Flat Washer: 1" SAE Yellow
31	32				07-10126	Grade 5 Flat Washer: 1-5/8" SAE
32	12				RHW6102	Grade 5 Lock Washer: 5/16"
33	1				RHW6202	Grade 5 Lock Washer: 3/8"
34	2				RHW7002	Grade 5 Lock Nut: 1/4"
35	1				RHW7202	Grade 5 Lock Nut: 3/8"
36	varies	(10)	(12)	(13)	(14) RHW7607	Grade 8 Top Lock Flange Nut: 5/8"
37	8				RHW8012	Grade 2 Cotter Pin: 1/8" x 2"
38	2				RHW8064	Lynch Pin: 7/16" x 1-5/8" (useable)
39	4				RHW8065	Grade 2 Spade Bolt: 5/8" x 4-3/4"
40	1				RHW8090	Grease Zerk: 1/4", 28 tpi., self-tapping
41	1				RHW8098	Grade 2 Fender Washer: 5/16" ID, 1-1/2" OD
42	1				RHW8613	Weld Plate: 7/8" OD
43	1				RHW8614	Hose Clamp Cover Plate: 7/8" OD
44	1				RHW8616	Hose Cradle: (2) 7/8" OD hoses
45	1				RHW8618	Hose Spring

NOTE: All parts are the same as the 11619 except for those parts numbered under the other model.

ITEM	QTY.	6' 11614	7-1/2' 11610	8-1/2' 11611	10' 11615	STEEL EDGE REPLACEMENT KIT DESCRIPTION
1	1	13-52843 (72")	102649 (90")	102650 (102")	13-52876 (119")	Wear Edge: 1/2 x 6 x length noted
27	varies	(6)	(8)	(9)	(10) RHW2663	Grade 8 Plow Bolt: 5/8" x 1-3/4"
36	varies	(6)	(8)	(9)	(10) RHW7607	Grade 8 Top Lock Flange Nut: 5/8"

SNOW BLADE PARTS LIST: 11600 Series

OPTIONAL KITS:

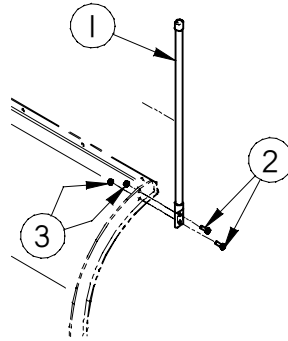

MARKER KIT F/ 116 TRIP EDGE BLADE: 11601			
ITEM	QTY.	PART #	DESCRIPTION
1	2	103066	MARKER ORANGE 28"
2	4	RHW1105	HHCS .31-18-1.00 GR 5
3	4	RHW7103	CTR DNT LOCK NUT .31 GR5

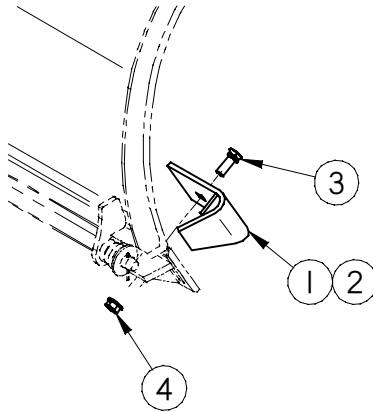

CURB GUARD KIT F/ 116 TRIP EDGE BLADE: 11603			
ITEM	QTY.	PART #	DESCRIPTION
1	1	103293	WELD CURB GUARD LH
2	1	103294	WELD CURB GUARD RH
3	2	RHW2664	PLOW .63-11-2.0 GR 8
4	2	RHW7607	.63-11 TOP LOCK FLANGE NUT GR8

SNOW BLADE PARTS LIST: 11600 Series

OPTIONAL KITS:

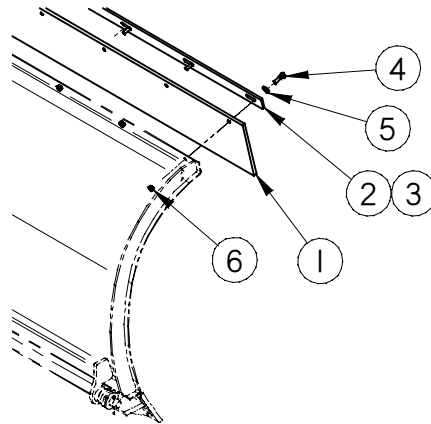

ITEM	QTY.	6' 11616	7-1/2' 11606	8-1/2' 11607	10' 11617	SNOW DEFLECTOR KIT DESCRIPTION
1	1	13-52870 (72")	103296 (90")	103299 (102")	13-52871 (119")	RUBBER DEFLECTOR LENGTH NOTED
2	varies	(1) 13-52874	(2) 13-51871	(1) 13-51871	(1) 13-52874	PLATE DEFLECTOR STRAP
3	1	n/a	n/a	13-51872	13-52875	PLATE DEFLECTOR STRAP
4	varies	(8)	(10)	(11)	(13) RHW1107	HHCS .31-18-1.25 GR 5
5	varies	(8)	(10)	(11)	(13) RHW5162	FLAT WSR USS .31 GR5
6	varies	(8)	(10)	(11)	(13) RHW7103	CTR DNT LOCK NUT .31 GR5

SNOW BLADE PARTS LIST: 11600 Series

OPTIONAL KITS:

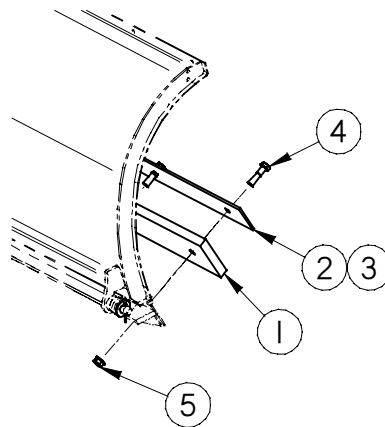

ITEM	QTY.	6' 11618	7-1/2' 11608	8-1/2' 11609	10' 11620	CUTTER BAR RUBBER KIT DESCRIPTION
1	1	13-52872 (72")	103331 (90")	103332 (102")	13-52873 (119")	RUBBER 1 x 6 x LENGTH NOTED
2	varies	(1) LAF9410	(2) 13-51902	(1) 13-51902	(2) LAF9409	PLATE RETAINER
3	1	n/a	n/a	13-51903	n/a	PLATE RETAINER
4	varies	(5)	(8)	(9)	(10) RHW1606	HHCS-.63-11-2.50 GR 5
5	varies	(5)	(8)	(9)	(10) RHW7607	.63-11 TOP LOCK FLANGE NUT GR8

HYDRAULIC CYLINDER
 ILLUSTRATION: 102654

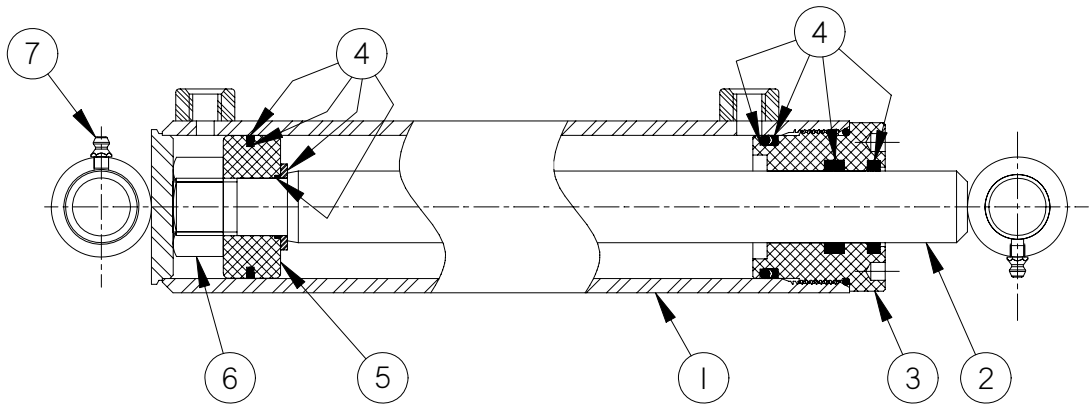

NUMBERS FROM HYDRAULIC CYLINDER ILLUSTRATION: 102654			
ITEM	QTY.	PART #	DESCRIPTION
1	1	03-10092	Barrel: 1-1/2" ID x 11-1/2" Stroke with Cross Tube End
2	1	102663	Shaft: 1-1/2" Diameter with Drilled End
3	1	03-10093	Head: 1-1/2" ID, nominal
4	1	03-10094	Seal Kit (includes all seals, o-rings, etc.)
5	1	03-10098	Piston: 2-1/2" OD x 1" ID Nominal
6	1	1483	Nut: 1.00 – 14, O Lock
7	2	RHW8090	Grease Zerk: 1/4", 28 tpi., Self-Tapping

SNOW BLADE SPECIFICATIONS

Model Number	Overall Width	Overall Height*	Overall Depth	Cutting Width		Shipping Weight
				Straight	Max. Angle	
11600 SERIES**						
11672	72"	32-3/16"	41-5/16"	72"	62-3/8"	670 lbs
11690	90"	32-3/16"	41-5/16"	90"	77-7/8"	816 lbs.
11602	102"	32-3/16"	41-5/16"	102"	88-1/4"	925 lbs.
11619	119"	32-3/16"	41-5/16"	119	103"	1040 lbs.
All replacement hydraulic hoses and fittings must have a minimum rated working pressure of 4,000 psi.						

* The overall height is also the height of the moldboard without the optional flap.

** The maximum angle is 30 degrees.

TORQUE SPECIFICATION FOR STANDARD MACHINE HARDWARE

Bolt Size	SAE Grade Bolt	Torque Ft./Lbs.	Bolt Size	SAE Grade Bolt	Torque Ft./Lbs.
1/4" - 20	8	7.6	5/8" - 11	5	150
5/16" - 18	5	15	3/4" - 10	5	300
3/8" - 16	5	30	3/4" - 10	8	200
3/8" - 16	8	45	1" - 8	5	250
1/2" - 13	5	75			



PALADIN LIGHT CONSTRUCTION

Warranty Registration Form and Delivery Inspection Report

IMPORTANT! Warranty **Void** if card is not returned with 10 days.
All Applicable sections **must** be filled in.

This section to be filled out and signed by Dealer at time of delivery.

Warranty Registration

Customer's Name _____	Dealer's Name _____
Address _____	Address _____
City _____ State _____ Zip _____	City _____ State _____ Zip _____
Phone _____	CHECK ONE:
Loader / Tractor Model _____	Construction Use _____
Delivery Date _____	Agricultural Use _____
Model or Part # _____	Landscape Use _____
Serial # _____	Other: _____

Dealer Inspection *(check items applicable)*

- | | |
|--|--|
| _____ All Decals installed (see operator's manual) | _____ Review Operating and Safety Instructions |
| _____ Hydraulic fittings tight and free of leaks | _____ Guards and covers in place and secure |
| _____ Fasteners tight | _____ Does Product Function Properly |

I have thoroughly instructed the buyer on the above described equipment. This review included: The Operator's manual content, equipment care, adjustments, safe operation and applicable warranty policy.

Date _____ Dealer's Rep. signature _____

This section to be completed and signed by the customer

	1 Excellent	2 Good	3 Average	4 Unsatisfactory	5 Poor
QUALITY ASSURANCE RATING					
Question:		FFC		Local Dealer	
Quality of Product: Appearance		_____		_____	
Construction		_____		_____	
Quality of Service		_____		_____	
Value (Priced Fairly)		_____		_____	
Does it perform as claimed		_____		_____	

The above described equipment and Operator's Manual have been received by me and I have been thoroughly instructed as to care, adjustments, safe operation and applicable warranty policy.

Date: _____ Owner's signature _____

NOTE! Make one copy each for the dealer's and owner's records. Mail original to FFC Attachments.



PALADIN LIGHT CONSTRUCTION

FFC LIMITED 12 MONTH WARRANTY

Thank you for purchasing a FFC product. Warranty protection is valid only when this Warranty Registration is completed and signed by the customer and dealer, and mailed to FFC. I hereby acknowledge that I have received a copy of the owners Limited Warranty and I accept the terms therein.

For a period of 12 months from date of delivery of product to the original user, FFC, warrants each product to be free from manufacturing defects, subject to the limitations contained in this policy.

This warranty does not apply to defect caused, in whole or in part, by unreasonable use while in the possession of the user, including, but not limited to: failure to properly set up product; failure to provide reasonable and necessary maintenance; normal wear; routine tune ups or adjustments; improper handling or accidents; operation at speed or load conditions contrary to published specification; improper or insufficient lubrication; improper storage. This warranty is also not a guarantee that the performance of each product will meet the expectations of the purchaser.

FFC shall not be liable for consequential damages of any kind, including, but not limited to: consequential labor costs or transportation charges in connection with the replacement or repair of defective parts; lost time or expense which may have accrued because of said defects. In no event shall FFC, Inc.'s total liability hereunder exceed the product purchase price.

FFC makes no warranty with respect to trade accessories or any component or accessory of the product which was not manufactured by FFC, including any purchased components on any kind. These are subject to the warranties of their respective manufacturers. The warranty will be considered void if the product or any part of the product is modified or repaired in any way not expressly authorized by FFC, or if closed components are disassembled prior to return. Closed components include, but are not limited to: gearboxes, hydraulic pumps, motors, cylinders, and actuators.

Our obligation under the warranty is expressly limited, at our option, to the replacement or repair at FFC, of Lee, Illinois, or at a service facility designated by us, or such part or parts as inspection shall disclosed to have been defective. We are not responsible for unauthorized repairs or replacements. Any implied or statutory warranties, including any warranty of merchantability or fitness for a particular purpose, are expressly limited to the duration of this written warranty. We make no other express or implied warranty, nor is anyone authorized to make any in our behalf. This warranty cannot be extended, broadened, or changed except in writing by an authorized officer of FFC.