

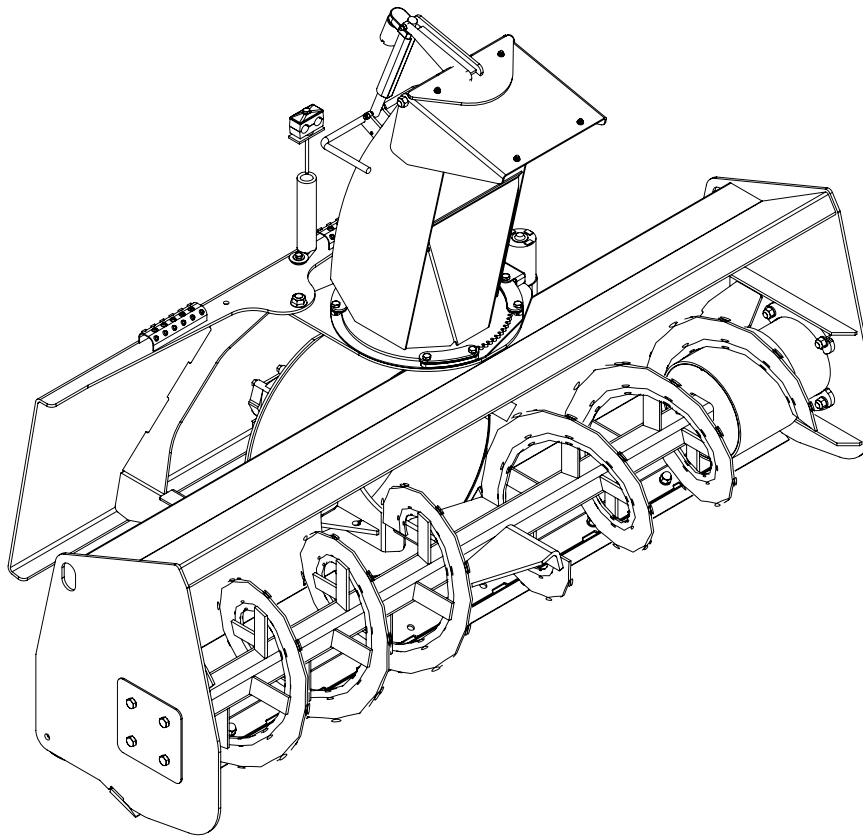

HYDRAULIC SNOW BLOWER



PALADIN LIGHT CONSTRUCTION



FFC SERIAL NUMBER: _____

MACHINE SERIAL NUMBER: _____

Manual Number: MR45576

Models:

STD: LAF6748 with MOTOR KIT: (A);

STD: 11005, 11006, 11008 and 11007

with MOTOR KIT: (C) (D) or (E);

HF: LAF6774, 11009, LAF6786, and LAF6798

with MOTOR KIT: (F) (G) or (H)

Release Date: October, 2007

TABLE OF CONTENTS

INTRODUCTION	2
GENERAL INFORMATION	2
SERIAL NUMBER	2
OWNER AND OPERATOR SAFETY INFORMATION	
SAFETY STATEMENTS	3
SAFETY PRECAUTIONS	3-6
SAFETY SIGNS	7
SPECIFICATIONS	8
MOUNTING	9-10
HYDRAULIC CONNECTION	10
SETUP	11
OPERATION	12-13
MAINTENANCE	14
SERVICE	15
PARTS ILLUSTRATION	
48" STANDARD	16, 19
60", 72", 78" & 84" STANDARD	20, 23
HIGH FLOW	24-25
PARTS LIST	
48" STANDARD	17-19
60", 72", 78" & 84" STANDARD	21-23
HIGH FLOW	26-28
JOY STICK ILLUSTRATIONS	29-30
WARRANTY	i

INTRODUCTION

Congratulations on your purchase of a new FFC Hydraulic Snow Blower. This product has been designed and built to push loose material forward, primarily snow and manure. You or any other person who will be assembling, operating, maintaining, or working with this product are required to read and completely understand the information and instructions contained in this manual. If anyone does not fully understand every part of this manual, please obtain further assistance by contacting the dealer from which this product was purchased or by contacting FFC at the telephone number or address listed on the cover of this manual. Keep this manual available for reference whenever this product is being handled or used. Provide this manual to any new owners and/or operators.

This manual covers model(s): **LAF6748** with **MOTOR KIT (A)**; **11005**, **11006**, **11008** and **11007** with a **MOTOR KIT (C, D, or E)**; and **LAF6774**, **11009**, **LAF6786** and **LAF6798** with a **MOTOR KIT (F, G, or H)**. The difference between the models is the width and hydraulic flow capacity of the product, details of which are covered on the parts list and specifications page(s).

GENERAL INFORMATION

The purpose of this manual is to assist in assembling, mounting, operating, and maintaining your Hydraulic Snow Blower. Read this manual carefully to obtain valuable information and instructions that will help you achieve years of safe and dependable service.

The illustrations and data used in this manual were current at the time of printing, but due to possible engineering and/or production changes, this product may vary slightly in detail. FFC reserves the right to redesign and/or change components as may be necessary without notification to anyone.

Throughout this manual, references may be made to:

Prime Mover	The engine-driven machine to which this product must be attached.
Right, Left, Front, Rear	Directions that are determined in relation to the operator of the equipment when seated in the normal operation position.
IMPORTANT	Precautions that must be followed to prevent substandard performance.

SERIAL NUMBER LOCATION

Always refer to the model and serial number when ordering parts or requesting information from your dealer. The serial number plate for this product is located on the top left surface of the loader attachment plate of your Hydraulic Snow Blower.

Reference Information	
Model Number	Loader Make
Serial Number	Loader Model
Date Purchased	Loader Serial Number

SAFETY STATEMENTS



THIS SYMBOL BY ITSELF OR WITH A WARNING WORD THROUGHOUT THIS MANUAL IS USED TO CALL YOUR ATTENTION TO INSTRUCTIONS INVOLVING YOUR PERSONAL SAFETY OR THE SAFETY OF OTHERS. FAILURE TO FOLLOW THESE INSTRUCTIONS CAN RESULT IN INJURY OR DEATH.



DANGER

THIS SIGNAL WORD IS USED WHERE SERIOUS INJURY OR DEATH WILL RESULT IF THE INSTRUCTIONS ARE NOT FOLLOWED PROPERLY.



WARNING

THIS SIGNAL WORD IS USED WHERE SERIOUS INJURY OR DEATH COULD RESULT IF THE INSTRUCTIONS ARE NOT FOLLOWED PROPERLY.



CAUTION

THIS SIGNAL WORD IS USED WHERE MINOR INJURY COULD RESULT IF THE INSTRUCTIONS ARE NOT FOLLOWED PROPERLY.

NOTICE

NOTICE INDICATES A PROPERTY DAMAGE MESSAGE.

GENERAL SAFETY PRECAUTIONS

WARNING! READ MANUAL PRIOR TO INSTALLATION



Improper installation, operation, or maintenance of this equipment could result in serious injury or death. Operators and maintenance personnel should read this manual, as well as all manuals related to this equipment and the prime mover thoroughly before beginning installation, operation, or maintenance. **FOLLOW ALL SAFETY INSTRUCTIONS IN THIS MANUAL AND THE PRIME MOVER'S MANUAL(S).**



READ AND UNDERSTAND ALL SAFETY STATEMENTS

Read all safety decals and safety statements in all manuals prior to operating or working on this equipment. Know and obey all OSHA regulations, local laws, and other professional guidelines for your operation. Know and follow good work practices when assembling, maintaining, repairing, mounting, removing, or operating this equipment.



KNOW YOUR EQUIPMENT

Know your equipment's capabilities, dimensions and operations before operating. Visually inspect your equipment before you start, and never operate equipment that is not in proper working order with all safety devices intact. Check all hardware to ensure it is tight. Make certain that all locking pins, latches, and connection devices are properly installed and secured. Remove and replace any damaged, fatigued, or excessively worn parts. Make certain all safety decals are in place and are legible. Keep decals clean, and replace them if they become worn and hard to read.

GENERAL SAFETY PRECAUTIONS

WARNING! PROTECT AGAINST FLYING DEBRIS



Always wear proper safety glasses, goggles or a face shield when driving pins in or out, or when any operation causes dust, flying debris, or any other hazardous material.

WARNING! LOWER OR SUPPORT RAISED EQUIPMENT



Do not work under raised booms without supporting them. Do not use support material made of concrete blocks, logs, buckets, barrels or any other material that could suddenly collapse or shift positions. Make sure support material is solid, not decayed, warped, twisted, or tapered. Lower booms to ground level or onto blocks. Lower booms and attachments to the ground before leaving the cab or operator's station.

WARNING! USE CARE WITH HYDRAULIC FLUID PRESSURE



Hydraulic fluid under pressure can penetrate the skin and cause serious injury or death. Hydraulic leaks under pressure may not be visible. Before connecting or disconnecting hydraulic hoses, read your prime movers operator's manual for detailed instructions on connecting and disconnecting hydraulic hoses or fittings.

- Keep unprotected body parts, such as face, eyes, and arms as far away as possible from a suspected leak. Flesh injected with hydraulic fluid may develop gangrene or other permanent disabilities.
- If injured by injected fluid, see a doctor at once. If your doctor is not familiar with this type of injury, ask him to research immediately to determine proper treatment.
- Wear safety glasses, protective clothing, and use a sound piece of cardboard or wood when searching for hydraulic leaks. **DO NOT USE YOUR HANDS!** **SEE ILLUSTRATION.**

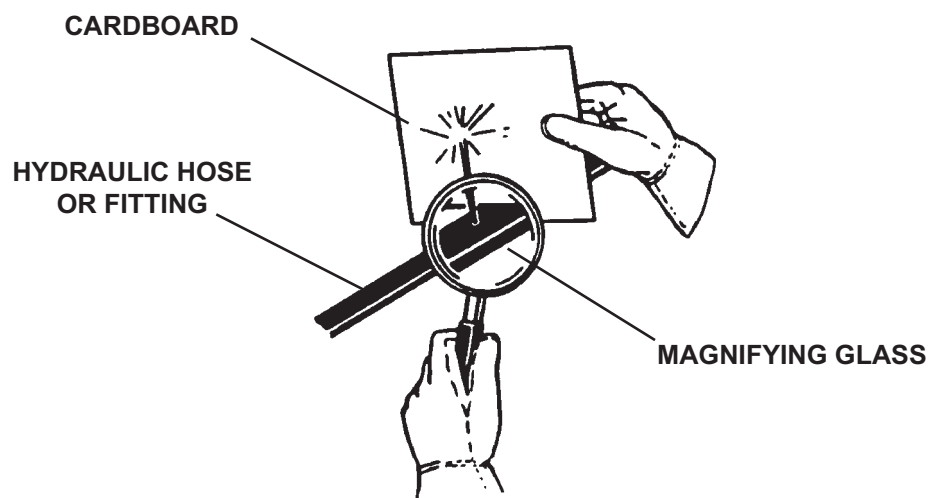

GENERAL SAFETY PRECAUTIONS

WARNING! DO NOT MODIFY MACHINE OR ATTACHMENTS



Modifications may weaken the integrity of the attachment and may impair the function, safety, life, and performance of the attachment. When making repairs, use only the manufacturer's genuine parts, following authorized instructions. Other parts may be substandard in fit and quality. Never modify any ROPS (Roll Over Protection Structure) or FOPS (Falling Object Protective Structure) equipment or device. Any modifications must be authorized in writing by the manufacturer.

WARNING! SAFELY MAINTAIN AND REPAIR EQUIPMENT



- Do not wear loose clothing, or any accessories that can catch in moving parts. If you have long hair, cover or secure it so that it does not become entangled in the equipment.
- Work on a level surface in a well-lit area.
- Use properly grounded electrical outlets and tools.
- Use the correct tool for the job at hand. Make sure they are in good condition for the task required.
- Wear the protective equipment specified by the tool manufacturer.

WARNING! SAFELY OPERATE EQUIPMENT



Do not operate equipment until you are completely trained by a qualified operator in how to use the controls, know its capabilities, dimensions, and all safety requirements. See your machine's manual for these instructions.

- Keep all step plates, grab bars, pedals, and controls free of dirt, grease, debris, and oil.
- Never allow anyone to be around the equipment when it is operating.
- Do not allow riders on the attachment or the prime mover.
- Do not operate the equipment from anywhere other than the correct operators position.
- Never leave equipment unattended with the engine running or with this attachment in a raised position.
- Do not alter or remove any safety feature from the prime mover or this attachment.
- Know your work site safety rules as well as traffic rules and flow. When in doubt on any safety issue, contact your supervisor or safety coordinator for an explanation.

WARNING! KNOW WHERE UTILITIES ARE



Observe overhead electrical and other utility lines. Be sure equipment will clear them. When digging, call your local utilities for location of buried utility lines, gas, water, and sewer, as well as any other hazard you may encounter.

EQUIPMENT SAFETY PRECAUTIONS

DANGER!



ROTATING OBJECTS

- Never allow anyone to reach into, kick into, or otherwise come in contact with a rotating auger or with a non-rotating clogged auger. The auger can crush and/or dismember. Keep everyone clear of the auger until the prime mover engine is off and the hydraulic pressure has been relieved.
- Never allow anyone to reach into the chute, force objects (i.e. bars, poles, etc.) down the chute, kick into the fan, or otherwise come in contact with a rotating fan or with a non-rotating clogged fan. The fan can throw objects at a lethal speed and can dismember. Keep everyone clear of the fan until the prime mover engine is off and the hydraulic pressure has been relieved.

CAUTION!



AVOID ELECTRICAL SHOCK

- To avoid electrical shock during the wiring harness installation, remove the ground cable from the battery of your prime mover.
- Be aware that turning off the prime mover key does not cut the power to the chute rotation motor or to the chute deflector actuator. With the switches for these devices being powered 100% of the time, care must be taken to not engage these switches:
 - accidentally at any time, especially when entering or leaving the prime mover operator's position, or
 - when others are working on or near the actuator, the deflector, the chute, or any other part of this product that could cause personal injury if the switch or switches are engaged.
- Avoid pinch points and be aware of rotating parts when manually turning the fan or auger.

SAFETY SIGN LOCATIONS

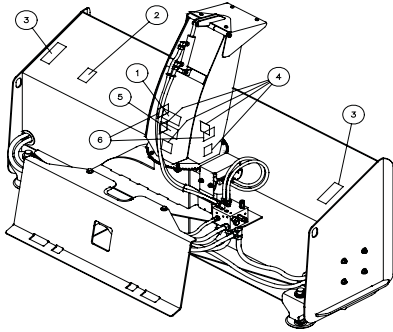

ITEM	QTY.	PART #	DESCRIPTION
1	1	50-10017	Read Manual
2	1	50-0724	Hydraulics
3	2	RDL3161	Rotating Auger
4	4	50-0737	Pinch Point
5	1	50-0727	Flying Objects
6	2	RDL3163	Rotating Fan

INSTRUCTIONS

- Keep all safety signs clean and legible.
- Replace all missing, illegible, or damaged safety signs.
- Replacement parts for parts with safety signs attached must also have safety signs attached.
- Safety signs are available, free of charge, from your dealer or from FFC.

PLACEMENT OR REPLACEMENT OF SAFETY SIGNS

1. Clean the area of application with non-flammable solvent, and then wash the same area with soap and water.
2. Allow the surface to fully dry.
3. Remove the backing from the safety sign, exposing the adhesive surface.
4. Apply the safety sign to the position shown in the diagram above and smooth out any bubbles.

ITEM 1

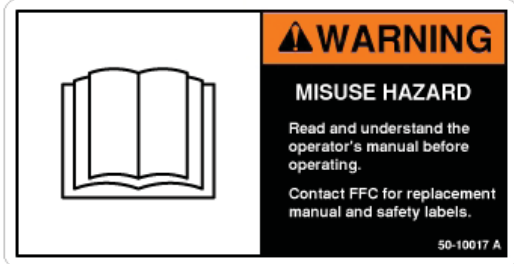

ITEM 2



ITEM 3

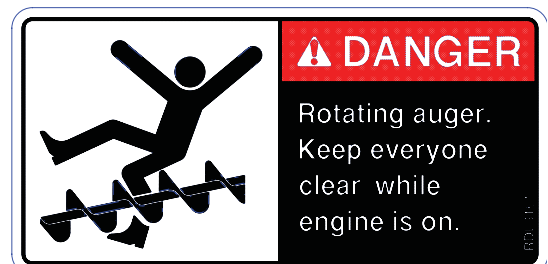

ITEM 4



ITEM 5



ITEM 6



PRIME MOVER SPECIFICATIONS

IMPORTANT Exceeding any of the maximum recommended prime mover specifications **CAN** result in damage to this product and **WILL** void all FFC warranties.

DESCRIPTION	SPECIFICATIONS		
	All Models Motor Kit (A)	All Models Motor Kit (C) (D) or (E)	All Models Motor Kit (F) (G) or (H)
Weight of Prime Mover without Snow Blower	8,000 lbs. maximum	11,000 lbs. maximum	11,000 lbs maximum
Hydraulic Pressure Output	3,000 psi maximum	3,000 psi maximum	3,500 psi maximum
Hydraulic Flow Output	13 gpm maximum	15 (C), 21 (D) or 27 (E) gpm maximum	34 (F & G) or 42 (H) gpm maximum
Rear Ballast	As required to maintain full prime mover stability. (Note the Shipping Weight on the specifications page, then see the operator's manual(s) for your prime mover, loader, and quick-attach for ballasting needs.)		

NOTICE Make sure your prime mover is producing the manufacturer's specified hydraulic flow (gpm) and pressure (psi), especially for operation at high altitudes. Using prime movers with less than specified flow or pressure will cause your Snow Blower to perform in a substandard manner.

HYDRAULIC SNOW BLOWER SPECIFICATIONS

Model Number	Overall Width	Overall Height	Overall Depth	Cutting Width	Shipping Weight*
LAF6748	48"	55-1/2"	37"	48"	490 lbs.
11005	60"	55-1/2"	37"	60"	687 lbs.
11006	72"	55-1/2"	37"	72"	724 lbs.
11008	78"	55-1/2"	37"	78"	742 lbs.
11007	84"	55-1/2"	37"	84"	761 lbs.
LAF6774	75"	74"	43"	73-1/2"	1180 lbs.
11009	81"	74"	43"	79-1/2"	1220 lbs.
LAF6786	87"	74"	43"	85-1/2"	1260 lbs.
LAF6798	99"	74"	43"	97-1/2"	1340 lbs.

All replacement hydraulics must have a minimum rated working pressure of 3,500 psi.

*NOTE: Increase the shipping weight by 10 lbs. if "E" motor is used, and decrease the shipping weight by 10 lbs. if "F" motor is used.

TORQUE SPECIFICATIONS FOR STANDARD MACHINE HARDWARE (FOR REFERENCE ONLY)

Bolt Size	SAE Grade Bolt	Torque Ft./ Lbs	Bolt Size	SAE Grade Bolt	Torque Ft./ Lbs
10-24	5	43	3/8" - 16	5	30
1/4" - 20	5	8	1/2" - 13	5	75
1/4" - 20	8	12	5/8" - 11	5	150
5/16" - 18	5	17			

HYDRAULIC SNOW BLOWER MOUNTING

WARNING! READ MANUAL PRIOR TO INSTALLATION



Improper installation, operation, or maintenance of this equipment could result in serious injury or death. Operators and maintenance personnel should read this manual, as well as all manuals related to this equipment and the prime mover thoroughly before beginning installation, operation, or maintenance. **FOLLOW ALL SAFETY INSTRUCTIONS IN THIS MANUAL AND THE PRIME MOVER'S MANUAL(S).**

1. Place this product on a firm, level surface that is large enough to safely accommodate this product, your prime mover and all workers involved in the mounting process.
2. Refer to the operator's manual(s) for your prime mover, loader, and quick-attach and follow the mounting instructions contained therein.
3. Carefully raise the loader and cycle the tilt cylinders to check clearances and to verify that all mounting procedures have been successfully completed.

IMPORTANT Lubricate all grease fittings before connecting this product to your prime mover's hydraulic system. Refer to **HYDRAULIC SNOW BLOWER MAINTENANCE** and follow the instructions

ELECTRIC ACTUATOR AND WIRING HARNESS INSTALLATION

MATERIALS NEEDED: Nylon cable ties

1. Park your prime mover on a level surface with this product properly attached.
2. Place your prime mover's transmission in "Park" and engage the parking brake.
3. Lower this product onto the level surface.
4. Shut off your prime mover's engine, remove the starter key, wait for all moving parts to come to a stop, and relieve all pressure in the hydraulic lines.
5. Remove the shipping material holding the top of the electric actuator to the chute and remove the bolt and nut from the deflector's actuator connection point. Secure the top of the actuator to the deflector using that bolt and nut.

(For units that are plugged in directly to the battery, continue with steps 6 thru 16.)

6. Attach the control box to the left side screen of your prime mover's roll-over protective structure (ROPS). Use the magnet on back of the control box to secure the control box so that the box is flat against the screen, the toggle switches are on the top, and the wiring harness cables are on the bottom.

WARNING! Failure to obey the following procedures could result in death or serious injury.



- Before doing any work on your prime mover's battery, read and understand all prime mover instructions and safety signs for your prime mover's electrical system. Pay special attention to hazard avoidance and remedial action related to explosive gas and acid.

HYDRAULIC SNOW BLOWER MOUNTING

CAUTION! Failure to obey the following procedures may result in personal injury.



- To avoid electrical shock during the wiring harness installation, remove the ground cable from the battery of your prime mover.

7. Remove the ground cable from the negative (-) post of your prime mover's battery.
8. Remove the nut from the **POSITIVE (+)** cable clamp on the battery and slide the **RED** wire ring terminal from the 9" wiring harness cable over the positive (+) cable clamp bolt. Secure the ring terminal with the nut.
9. Remove the nut from the **NEGATIVE (-)** cable clamp on the ground cable and slide the **BLACK** wire ring terminal from the 6' wiring harness cable over the negative (-) cable clamp bolt.
10. Reinstall the ground cable on the negative post of the battery and secure the ring terminal and the ground cable with the nut removed in the previous step.
11. Secure the 9' wiring harness cable from the battery to the control box with your nylon cable ties.
12. Feed the 16' wiring harness cable:
 - a) back to the left-rear area of your prime mover,
 - b) past the loader arm's rear hinge point by following the hydraulic hoses where possible, and
 - c) down the loader arm following the hydraulic lines.
13. Use your nylon cable ties to secure the 16' cable's female connector to the hydraulic lines next to the auxiliary hydraulic quick couplers.
14. Straighten the 16' cable and use your cable ties to secure the cable to the hydraulic lines back to the loader arm hinge point.
15. Allow sufficient slack in the cable at the hinge point to provide for a full range of motion of the loader arms. Use your nylon cable ties to secure the cable to the loader frame below the hinge point and back to the control box.
16. Connect the male connector on the actuator cable to the female connector on the loader arm.

HYDRAULIC SNOW BLOWER HYDRAULIC CONNECTION



READ AND UNDERSTAND ALL SAFETY STATEMENTS

Read all safety decals and safety statements in all manuals before beginning any Snow Blower hydraulic connection. Know and obey all OSHA regulations, local laws, and other professional guidelines for your operation. Know and follow good work practices when assembling, maintaining, repairing, mounting, removing, or operating this equipment.

1. Disconnect the hydraulic hose quick couplers from one another and attach the quick couplers to your prime mover as per the instructions in your prime mover's operator's manual. (Also see Hydraulic Hose Connections in the SERVICE section.)
2. Carefully raise the loader and cycle the tilt cylinders to check hose clearances and to check for any interference. Operate the chute and deflector on this product to make the same checks.
3. Cycle the hydraulic cylinder(s) on this product several times from fully retracted to fully extended until all air has been completely removed from the cylinder(s).

WARNING! Do not lock the auxiliary hydraulics of your prime mover in the "ON" position. Failure to obey this warning could result in death or serious injury.



HYDRAULIC SNOW BLOWER SETUP



READ AND UNDERSTAND ALL SAFETY STATEMENTS

Read all safety decals and safety statements in all manuals before beginning any Snow Blower setup. Know and obey all OSHA regulations, local laws, and other professional guidelines for your operation. Know and follow good work practices when assembling, maintaining, repairing, mounting, removing, or operating this equipment.

SKID SHOE ADJUSTMENT

Determine what type of surface is beneath the snow where your Hydraulic Snow Blower is being operated.

- If the surface is hard and smooth, like concrete or asphalt, the skid shoe placement as shipped from the factory (i.e. in their highest position) is correct.
- If the surface is soft or uneven, then a lower position should be used.

Changing the position of the skid shoes should be performed as follows:

1. Park your prime mover on a level surface with this product properly attached.
2. Place your prime mover's transmission in "Park" and engage the parking brake.
3. Lower this product's cutting edge onto wood or steel blocking that is adequate to safely hold the base of the skid shoes 2-1/2" to 3" off of the level surface OR tilt the snow blower forward (keeping the loader arms locked to the attachment mounting plate), holding the skid shoes 2-1/2" to 3" off the ground.
4. Shut off your prime mover's engine, remove the starter key, wait for all moving parts to come to a stop, and relieve all pressure in the hydraulic lines.

For the standard flow model (LAF6748):

5. Loosen the two nuts and remove the two bolts that secure one of the skid shoes.
6. Lower the skid shoe 1" or 2", which ever is appropriate for the surface beneath the snow, and resecure the skid shoe with the two bolts and nuts.
7. Repeat for the other skid shoe.

For the standard flow models (11005, 11006, 11008 and 11007) and the high flow models (LAF6774, 11009, LAF6786, and LAF6798):

5. Remove the lynch pin that secures the skid shoe.
6. Adjust the positioning and/or quantity of the machinery bushings to raise or lower the skid shoe. Resecure the skid shoe with the lynch pin at the desired height.
7. Repeat for the other skid shoe.

HYDRAULIC SNOW BLOWER OPERATION



READ AND UNDERSTAND ALL SAFETY STATEMENTS

Read all safety decals and safety statements in all manuals prior to operating or working on this equipment. Know and obey all OSHA regulations, local laws, and other professional guidelines for your operation. Know and follow good work practices when assembling, maintaining, repairing, mounting, removing, or operating this equipment.

DANGER!



Failure to obey the following procedures WILL result in death or serious injury.

- Never allow anyone to reach into, kick into, or otherwise come in contact with a rotating auger or with a non-rotating clogged auger. The auger can crush and/or dismember. Keep everyone clear of the auger until the prime mover engine is off and the hydraulic pressure has been relieved.
- Never allow anyone to reach into the chute, force objects (i.e. bars, poles, etc.) down the chute, kick into the fan, or otherwise come in contact with a rotating fan or with a non-rotating clogged fan. The fan can throw objects at a lethal speed and can dismember. Keep everyone clear of the fan until the prime mover engine is off and the hydraulic pressure has been relieved.

WARNING!



Failure to obey the following procedures could result in death or serious injury.

- Never place any object (i.e. bar, pole, stick, etc.) down the chute until the prime mover engine is off and the hydraulic pressure has been relieved.
- Do not operate this product until all others are clear of the entire discharge area. Foreign objects and pieces of ice are generally thrown farther than snow. High Flow Snow Blowers are capable of throwing material up to 45 feet.
- Do not operate this product when blowing or thrown snow restricts visibility.
- Do not lock the auxiliary hydraulics in the "ON" position.
- Never lift this product (a.) above the operator's eye level or (b.) to a height where visibility is obstructed, whichever is lower.

CAUTION!



Failure to obey the following procedures may result in personal injury.

- Be aware that turning off the power unit key does not cut the power to the winch or to the actuator. With the switches for these devices being powered 100% of the time, care must be taken to not engage these switches:
 - a) Accidentally at any time, especially when entering or leaving the prime mover operator's position, or
 - b) When others are working on or near the actuator, the deflector, the winch, the chute, or any other part of this product that could cause personal injury if the switches are engaged.

1. Try to remove snow as soon as possible after the snow falls; snow becomes more compact (and more difficult to throw) the longer it lies on the ground.
2. To maximize the snow moving capabilities, try to remove snow before the accumulation reaches 12".

NOTICE

Placing the loader arm hydraulics in the float position decreases the prime mover's capability to provide the desired hydraulic flow and pressure to your snow blower's motors. Snow throwing performance will therefore be reduced.

HYDRAULIC SNOW BLOWER OPERATION



READ AND UNDERSTAND ALL SAFETY STATEMENTS

Read all safety decals and safety statements in all manuals prior to operating or working on this equipment. Know and obey all OSHA regulations, local laws, and other professional guidelines for your operation. Know and follow good work practices when assembling, maintaining, repairing, mounting, removing, or operating this equipment.

3. Always rotate the chute and adjust the deflector so that the thrown snow is directed into open areas.

- IMPORTANT**
- **Holding the toggle switches in the powered position after the actuator has reached the end of that device's cycle of movement, and/or**
 - **Applying force on the deflector from any source, other than blown snow, that will cause the deflector to either compress or extend the deflector's actuator, and/or**
 - **Using your Snow Blower as a snow "plow" CAN result in damage to this product and WILL void all FFC warranties.**

4. Never direct the discharge at buildings, automobiles, trees, or any other item that may be damaged by thrown snow.
5. When blowing snow, approach the snow with the wind at the operator's back whenever possible.
6. When clearing a large area, cut the first pass on the upwind side and work downwind.
7. If an excessive amount of snow is being pushed in front of the auger housing, **SLOW DOWN!!** Allow the auger and fan enough time to properly collect and throw the snow.
8. If a foreign object becomes wedged in the auger, the auxiliary hydraulics on the prime mover may be reversed to reverse the auger. Reversing the auger rotation may remove the obstruction.
9. If a foreign object becomes wedged in the fan:
 - a) Move to a level surface, place your prime mover's transmission in "Park" and engage the parking brake.
 - b) Lower this product onto the level surface.
 - c) Shut off your prime mover's engine, remove the starter key, wait for all moving parts to come to a stop, and relieve all pressure in the hydraulic lines.
 - d) Disconnect the hydraulic fittings from your prime mover and reconnect those fittings to each other.

CAUTION! Failure to obey the following procedures may result in personal injury.



- **Avoid pinch points and be aware of rotating parts when manually turning fan or auger.**
- e) The fan can then be manually turned in a reverse rotation, allowing the foreign object to be removed.
 - f) Once the fan is free, reconnect the hydraulic fittings as per the instructions in the HYDRAULIC CONNECTION section of this manual.

HYDRAULIC SNOW BLOWER MAINTENANCE



READ AND UNDERSTAND ALL SAFETY STATEMENTS

Read all safety decals and safety statements in all manuals prior to operating or working on this equipment. Know and obey all OSHA regulations, local laws, and other professional guidelines for your operation. Know and follow good work practices when assembling, maintaining, repairing, mounting, removing, or operating this equipment.

BEFORE EACH USE

- Make sure that all nuts and bolts are in place and properly tightened.
- Make sure that all other fasteners are in place and are performing their specified function.
- Make sure that all hydraulic fittings are tightened and that there are no leaks in any fittings or hoses.
- Make sure that all safety signs are in place, are clean, and are legible.
(SEE THE SAFETY SIGN SECTION.)
- Replace any damaged parts and excessively worn parts.
- Make sure that the chute and the deflector are not frozen in place and are free to rotate. Attempting to move a frozen chute or deflector can cause the system's thermal overload protection to break the circuit. Resetting will occur automatically within a short amount of time.

AFTER EVERY 10 HOURS OF USE

- Grease all fittings as shown on the parts illustration.

HYDRAULIC SNOW BLOWER SERVICE



READ AND UNDERSTAND ALL SAFETY STATEMENTS

Read all safety decals and safety statements in all manuals prior to operating or working on this equipment. Know and obey all OSHA regulations, local laws, and other professional guidelines for your operation. Know and follow good work practices when assembling, maintaining, repairing, mounting, removing, or operating this equipment.

REPLACING THE CUTTING EDGE

1. Park your prime mover on a level surface with this product properly attached.
2. Place your prime mover's transmission in "Park" and engage the parking brake.
3. Lower this product's skid shoes onto wood or steel blocking that is adequate to safely hold the base of the skid shoes 2-1/2" to 3" off the level surface.
4. Shut off your prime mover's engine, remove the starter key, wait for all moving parts to come to a stop, and relieve all pressure in the hydraulic lines.
5. Remove all the acorn nuts, lock washers, and bolts except the one on each end of the cutting edge.
6. On one end of the cutting edge, remove the remaining acorn nut and lower the cutting edge to the work surface. Repeat for other end.
7. Properly dispose of the old cutting edge and install a new cutting edge by reversing the procedures in steps 6 and 5.

OTHER SERVICE RECOMMENDATIONS

FOR STANDARD FLOW MODEL (LAF6748) ONLY:

Auger Motor Replacement: When installing an auger motor, loosely install all four of the 8" bolts and fasteners. Fully tighten the three locknuts on the bolts inside the auger motor cover. Snug up the fourth bolt with the lock washer and nut, but do not over tighten.

IMPORTANT

**Over tightening the fourth bolt
CAN result in damage to this product and
WILL void all FFC warranties.**

FOR STANDARD FLOW MODELS (LAF6748, 11005, 11006, 11008 and 11007) ONLY:

Hydraulic Hose Connections: To make sure that the fan and auger motors' rotation is correct, the hose path must be: (a) from the prime mover to the top port of the fan motor, (b) from the bottom port of the fan motor to the top port of the auger motor, and (c) from the bottom port of the auger motor to the prime mover. (See PART ILLUSTRATION (Standard) section for the check valve location.)

SNOW BLOWER (48" Standard) PARTS LIST

		LAF6748	
		48"	
ITEM	QTY.	"A" Motor	DESCRIPTION
1	1	13-51119	Deflector
2	1	13-51136	Chute
3	1	13-52434	Motor Mount
4	1	LAF4579	Motor-Fan T-3.0 - 158- 2816
5	1	LAF4588	Motor T-14.9 - 158-1062
6	1	LAF6504	Actuator Mount
7	2	LAF6505	Roller Sleeve
8	1	LAF6509	Main Housing
9	1	LAF6520	Auger Hose Hole Liner
10	2	LAF6521	Skid Shoe
11	1	LAF6531	Electric Actuator
12	2	LAF6532	1-1/4 Dia 2 Bolt Flange Bearing
13	4	LAF6533	Rotation Clip Pad
14	1	LAF6535	Loader Attachment Plate
15	1	LAF6540	Fan Shaft
16	3	LAF6541	Fan Paddle
17	4	LAF6543	Chute Rotation Clip
18	4	LAF6545	Chute Rotation Spacer
19	1	LAF6547	Single Bevel Edge (3/8" x 3")
20	1	LAF6550	Auger
21	1	LAF6551	Deflector Liner
22	1	LAF6552	Three Blade Fan
23	1	LAF6596	Gear Cover
24	1	LAF6597	Chute Drive Sprocket
25	1	LAF6598	Chute Back Plate Liner
26	1	LAF6712	Chute Rotation Pad
27	1	LAF6719	Relay Clip for Actuator Bracket
28	1	LAF6721	Rotary Actuator 12 Volt DC
29	2	RHW1041	Grade 8 Hex Head Cap Screw 1/4" x 2"
30	1	RHW1105	Grade 5 Hex Head Cap Screw 5/16" x 1"
31	1	RHW1112	Grade 5 Hex Head Cap Screw 5/16" x 2-1/2"
32	4	RHW 1203	Grade 5 Hex Head Cap Screw 3/8" x 3/4"
33	6	RHW1207	Grade 5 Hex Head Cap Screw 3/8" x 1-1/4"
34	11	RHW1209	Grade 5 Hex Head Cap Screw 3/8" x 1-1/2"
35	1	RHW1215	Grade 5 Hex Head Cap Screw 3/8" x 3"

SNOW BLOWER (48" Standard) PARTS LIST (Continued)

		LAF6748	
		48"	
ITEM	QTY.	"A" Motor	DESCRIPTION
36	8	RHW1405	Grade 5 Hex Head Cap Screw 1/2" x 1-1/2"
37	2	RHW1407	Grade 5 Hex Head Cap Screw 1/2" x 2"
38	4	RHW1423	Grade 5 Hex Head Cap Screw 1/2" x 8"
39	1	RHW1430	Grade 5 Hex Head Cap Screw 1/2" x 12"
40	1	RHW1601	Grade 5 Hex Head Cap Screw 5/8" x 1-1/4"
41	4	RHW1604	Grade 5 Hex Head Cap Screw 5/8" x 2"
42	6	RHW2404	Grade 5 Carriage Bolt 1/2" x 1-1/4"
43	2	RHW4105	Allen Head Shoulder Screw 1/2" x 5/8" with 3/8"-16 x 5/8"
44	10	RHW5031	Grade 2 Flat Washer 3/16" SAE
45	1	RHW5162	Grade 5 Flat Washer 5/16" USS
46	3	RHW5262	Grade 5 Flat Washer 3/8" USS
47	5	RJW5632	Grade 5 Flat Washer 5/8" SAE
48	1	RHW6102	Grade 5 Lock Washer 5/16"
49	13	RHW6202	Grade 5 Lock Washer 3/8"
50	17	RHW6402	Grade 5 Lock Washer 1/2"
51	2	RHW7002	Grade 5 Nylock Nut 1/4"
52	1	RHW7101	Grade 5 Hex Nut 5/16"
53	11	RHW7201	Grade 5 Hex Nut 3/8"
54	9	RHW7203	Grade 5 Lock Nut 3/8"
55	12	RHW7401	Grade 5 Hex Nut 1/2"
56	4	RHW7403	Grade 5 Lock Nut 1/2"
57	6	RHW7408	Grade 2 Acorn Nut 1/2"
58	5	RHW7607	Grade 8 Top Lock Flange Nut 5/8"
59	1	RHW8032	Roll Pin 3/16" x 3/4"
60	1	RHW8034	Roll Pin 1/2" x 2"
61	1	RHW8098	Grade 2 Fender Washer 5/16" ID 1-1/2" OD
62	2	RHW8314	Loop Clamp 1/2"
63	1	RHW8613	Weld Plate 7/8" OD
64	1	RHW8614	Hose Clamp Cover Plate 7/8" OD
65	2	RHW8616	Hose Cradle (2) 7/8" OD Hoses
66	1	RHW8618	Hose Spring
67	9	RHW9001	Grade 5 Truss Head Machine Screw 3/16" x 3/4"
68	11	RHW9002	Grade 2 Lock Nut 3/16"
69	2	RHW9006	Grade 5 Truss Head Machine Screw 3/16" x 1"

HYDRAULIC/ELECTRIC (48"Standard) PARTS ILLUSTRATION & LIST

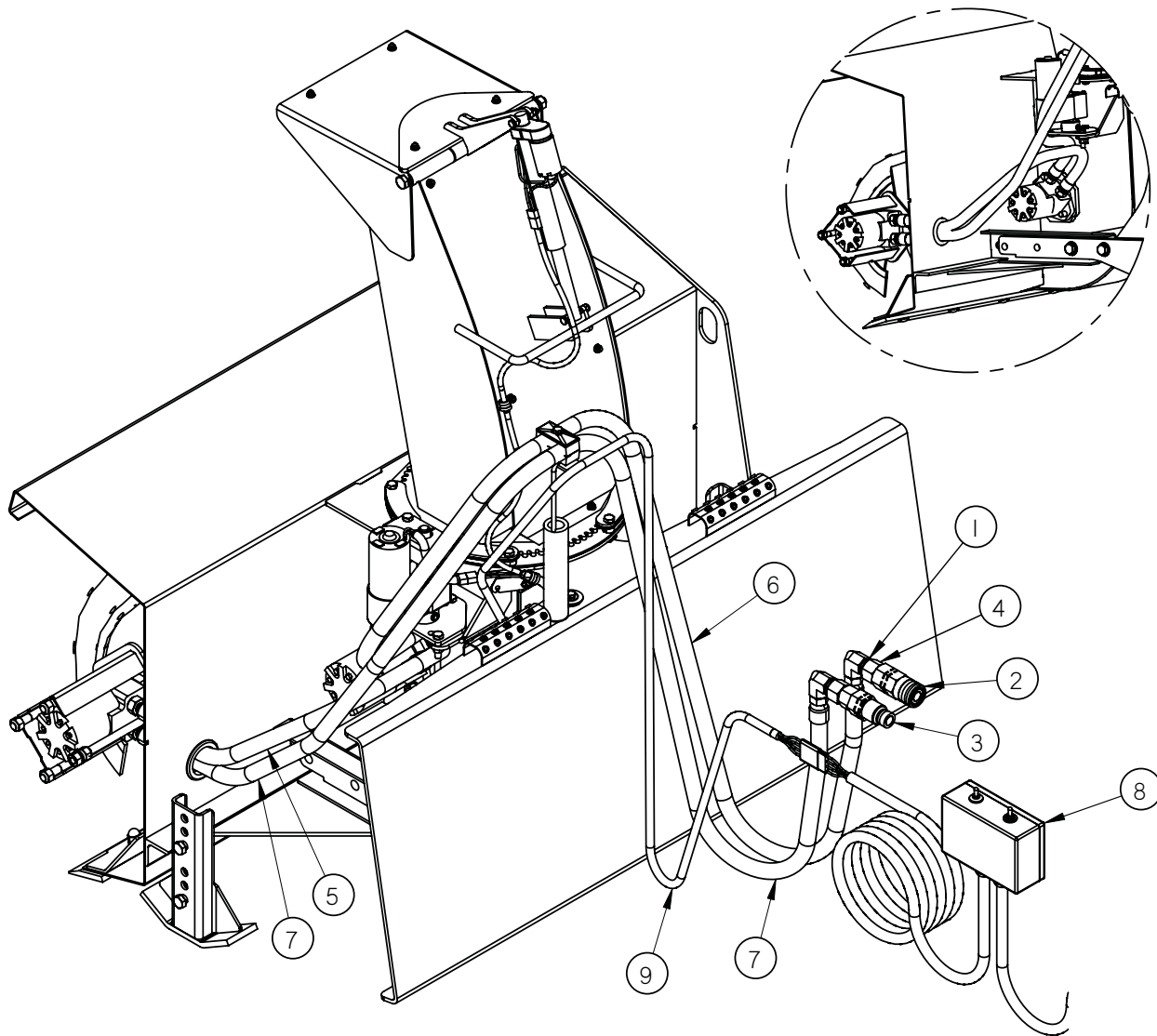

ITEM	QTY.	PART NUMBER	DESCRIPTION
1	2	Contact FFC to obtain the correct item	Hydraulic Adapter (not required for all models)
2	1	Contact FFC to obtain the correct item	Hydraulic Coupler Female
3	1	Contact FFC to obtain the correct item	Hydraulic Coupler Male
4	2	Contact FFC to obtain the correct item	Hydraulic Adapter (not required for all models)
5	1	LAF4315	Hydraulic Hose 1/2" x 36" 10MB – 10MBSW
6	1	LAF4317	Hydraulic Hose 1/2" x 84" 10MB – 10MB
7	1	LAF4345	Hydraulic Hose 1/2" x 108" 10MB – 10MB
8	1	Contact FFC to obtain the correct item	Wiring Harness
9	1	Contact FFC to obtain the correct item	Actuator Cable

SNOW BLOWER (Standard) PARTS ILLUSTRATION

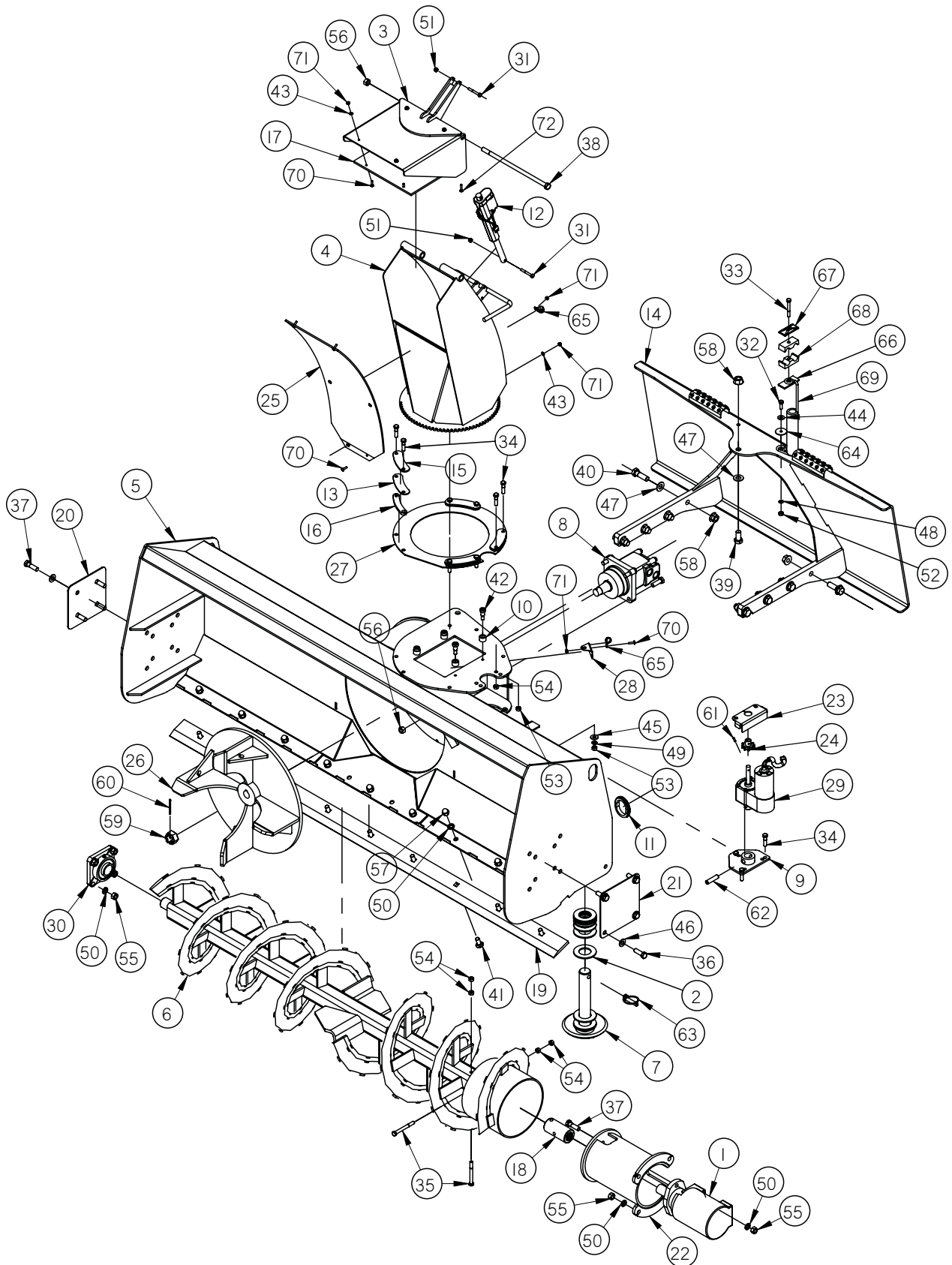

SNOW BLOWER (Standard) PARTS LIST

		11005	11006	11008	11007	
		60"	72"	78"	84"	
ITEM	QTY.	'C' 'D' or 'E' Motor	'D' or 'E' Motor	'D' or 'E' Motor	'D' or 'E' Motor	DESCRIPTION
1	1				03-10077	Auger Motor 17.1 Parker TF
2	22				07-10126	Grade 5 Flat Washer 1-5/8" SAE
3	1				13-51119	Deflector
4	1				13-51136	Chute
5	1	13-51802	13-51785	13-52900	13-51803	Main Housing
6	1	13-51790	13-51789	13-52905	13-51791	Auger
7	2				LAF1485	Skid Shoe
8	1	03-10054 (C) or (D) or (E)	(D) or (E)	(D) or (E)	LAF4576 (D) or LAF4575 (E)	Fan Motor: Motor C-Ross 4.0 Wheel MP Ser Motor D-2000 4.9 Wheel 105-1376 Motor E-2000 6.2 Wheel 105-1375
9	1				LAF6504	Actuator Mount
10	4				LAF6505	Roller Sleeve
11	1				LAF6520	Auger Hose Hole Liner
12	1				LAF6531	Electric Actuator
13	4				LAF6533	Rotation Clip Pad
14	1				LAF6535	Loader Attachment Plate
15	4				LAF6543	Chute Rotation Clip
16	4				LAF6545	Chute Rotation Spacer
17	1				LAF6551	Deflector Liner
18	1				LAF6567	Auger Sleeve
19	1	LAF6560	LAF6571	13-52909	LAF6583	Single Bevel Edge (3/8" x 3")
20	1				LAF6579	End Plate Cap for Bearing
21	1				LAF6580	End Plate Cap for Motor
22	1				LAF6593	Motor Mount
23	1				LAF6596	Gear Cover
24	1				LAF6597	Chute Drive Sprocket
25	1				LAF6598	Chute Back Plate Liner
26	1				LAF6708	Fan
27	1				LAF6712	Chute Rotation Pad
28	1				LAF6719	Relay Clip for Actuator Bracket
29	1				LAF6721	Rotary Actuator 12 Volt DC
30	1				LAF6808	Flange Mount Bearing 1-7/16 Id 4-bolt
31	2				RHW1041	Grade 8 Hex Head Cap Screw 1/4" x 2"
32	1				RHW1105	Grade 5 Hex Head Cap Screw 5/16" x 1"
33	1				RHW1112	Grade 5 Hex Head Cap Screw 5/16" x 2-1/2"
34	11				RHW1209	Grade 5 Hex Head Cap Screw 3/8" x 1-1/2"

NOTE: All parts are the same as the 11007 except for those parts numbered under the other models.

SNOW BLOWER (Standard) PARTS LIST (Continued)

		11005	11006	11008	11007	
		60"	72"	78"	84"	
ITEM	QTY.	'C' 'D' or 'E' Motor	'D' or 'E' Motor	'D' or 'E' Motor	'D' or 'E' Motor	DESCRIPTION
35	2				RHW1217	Grade 5 Hex Head Cap Screw 3/8" x 3-1/2"
36	8				RHW1405	Grade 5 Hex Head Cap Screw 1/2" x 1-1/2"
37	6				RHW1406	Grade 5 Hex Head Cap Screw 1/2" x 1-3/4"
38	1				RHW1430	Grade 5 Hex Head Cap Screw 1/2" x 12"
39	1				RHW1601	Grade 5 Hex Head Cap Screw 5/8" x 1-1/4"
40	8				RHW1604	Grade 5 Hex Head Cap Screw 5/8" x 2"
41	varies	(8)	(9)	(10)	(11) RHW2404	Grade 5 Carriage Bolt 1/2" x 1-1/4"
42	4				RHW4105	Allen Head Shoulder Screw 1/2" x 5/8" with 3/8"-16 x 5/8"
43	10				RHW5031	Grade 2 Flat Washer 3/16" SAE
44	1				RHW5162	Grade 5 Flat Washer 5/16" USS
45	3				RHW5262	Grade 5 Flat Washer 3/8" USS
46	8				RHW5492	Grade 8 Flat Washer 1/2" SAE Hardened
47	9				RHW5632	Grade 5 Flat Washer 5/8" SAE
48	1				RHW6102	Grade 5 Lock Washer 5/16"
49	3				RHW6202	Grade 5 Lock Washer 3/8"
50	varies	(18)	(19)	(20)	(21) RHW6402	Grade 5 Lock Washer 1/2"
51	2				RHW7002	Grade 5 Nylock Nut 1/4"
52	1				RHW7101	Grade 5 Hex Nut 5/16"
53	7				RHW7201	Grade 5 Hex Nut 3/8"
54	12				RHW7203	Grade 5 Lock Nut 3/8"
55	10				RHW7401	Grade 5 Hex Nut 1/2"
56	5				RHW7403	Grade 5 Lock Nut 1/2"
57	varies	(8)	(9)	(10)	(11) RHW7408	Grade 2 Acorn Nut 1/2"
58	9				RHW7607	Grade 8 Top Lock Flange Nut 5/8"
59	1				RHW7905	Castle Nut 1" x 1/2"
60	1				RHW8012	Grade 2 Cotter Pin 1/8" x 2"
61	1				RHW8032	Roll Pin 3/16" x 3/4"
62	1				RHW8034	Roll Pin 1/2" x 2"
63	2				RHW8064	Lynch Pin 7/16" x 1-5/8" Large Ring
64	1				RHW8098	Grade 2 Fender Washer 5/16" ID 1-1/2" OD
65	2				RHW8314	Loop Clamp 1/2"
66	1				RHW8613	Weld Plate 7/8" OD
67	1				RHW8614	Hose Clamp Cover Plate 7/8" OD
68	2				RHW8616	Hose Cradle (2) 7/8" OD Hoses
69	1				RHW8618	Hose Spring
70	9				RHW9001	Grade 5 Truss Head Machine Screw 3/16" x 3/4"
71	11				RHW9002	Grade 2 Lock Nut 3/16"
72	2				RHW9006	Grade 5 Truss Head Machine Screw 3/16" x 1"

NOTE: All parts are the same as the 11007 except for those parts numbered under the other models.

HYDRAULIC/ELECTRIC (Standard) PARTS ILLUSTRATION & LIST

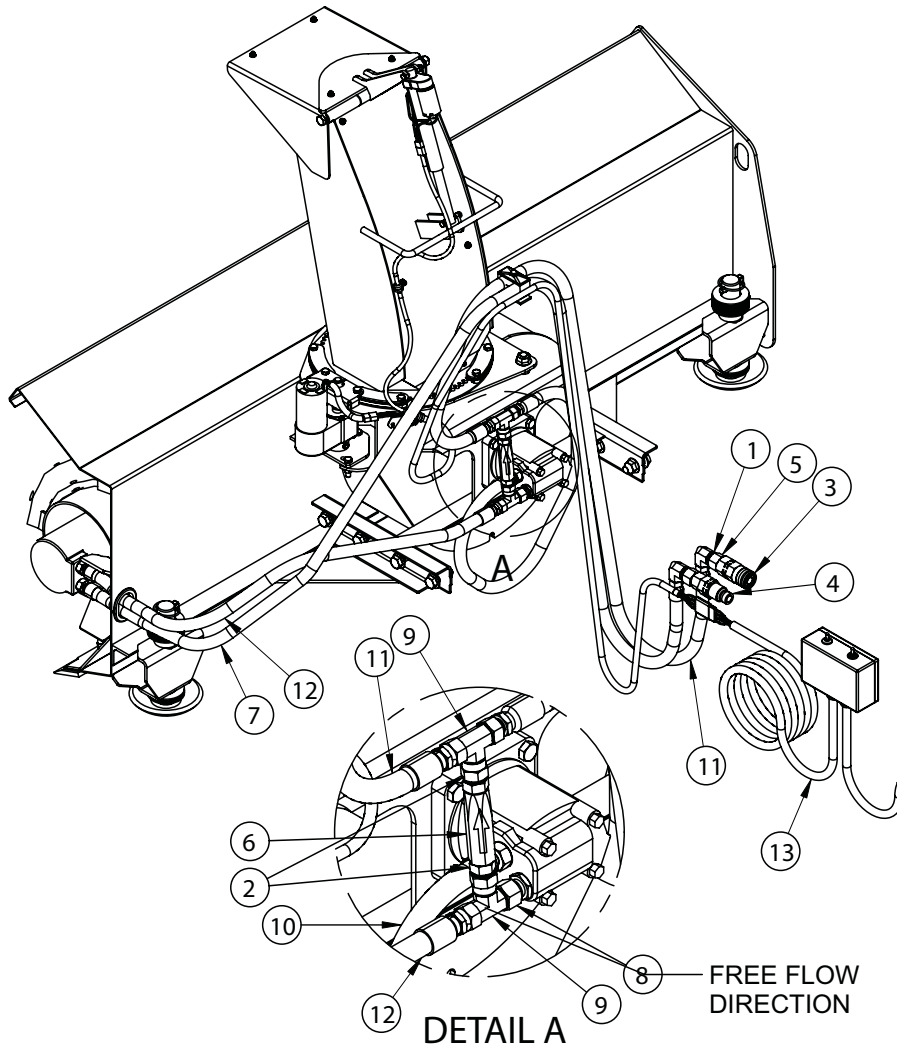

ITEM	QTY.	PART NUMBER	DESCRIPTION
1	2	Contact FFC to obtain the correct item	Hydraulic Adapter (not required for all models)
2	2	LAF4192	Hydraulic Adapter 8MB – 10MJ
3	1	Contact FFC to obtain the correct item	Hydraulic Coupler Female
4	1	Contact FFC to obtain the correct item	Hydraulic Coupler Male
5	2	Contact FFC to obtain the correct item	Hydraulic Adapter (not required for all models)
6	1	LAF4266	Check Valve 16 gpm, 3500 psi, 8FB ports
7	1	LAF4345	Hydraulic Hose 1/2" x 108" 10MB – 10MB
8	1	LAF4404	Hydraulic Adapter 10MB-10FJ, Straight Swivel
9	2	LAF4422	Hydraulic Branch Tee 10MJ – 10MJ – 10FJX
10	1	LAF4540	Hydraulic Hose 1/2" x 34" 10MB – 10FJ
11	1	LAF4552	Hydraulic Hose 1/2" x 84" 10MB – 10FJ
12	1	LAF4744	Hydraulic Hose 1/2" x 48" 10MB – 10FJ
13	1	Contact FFC to obtain the correct item	Wiring Harness
14	1	Contact FFC to obtain the correct item	Actuator Cable

SNOW BLOWER (High Flow) PARTS ILLUSTRATION

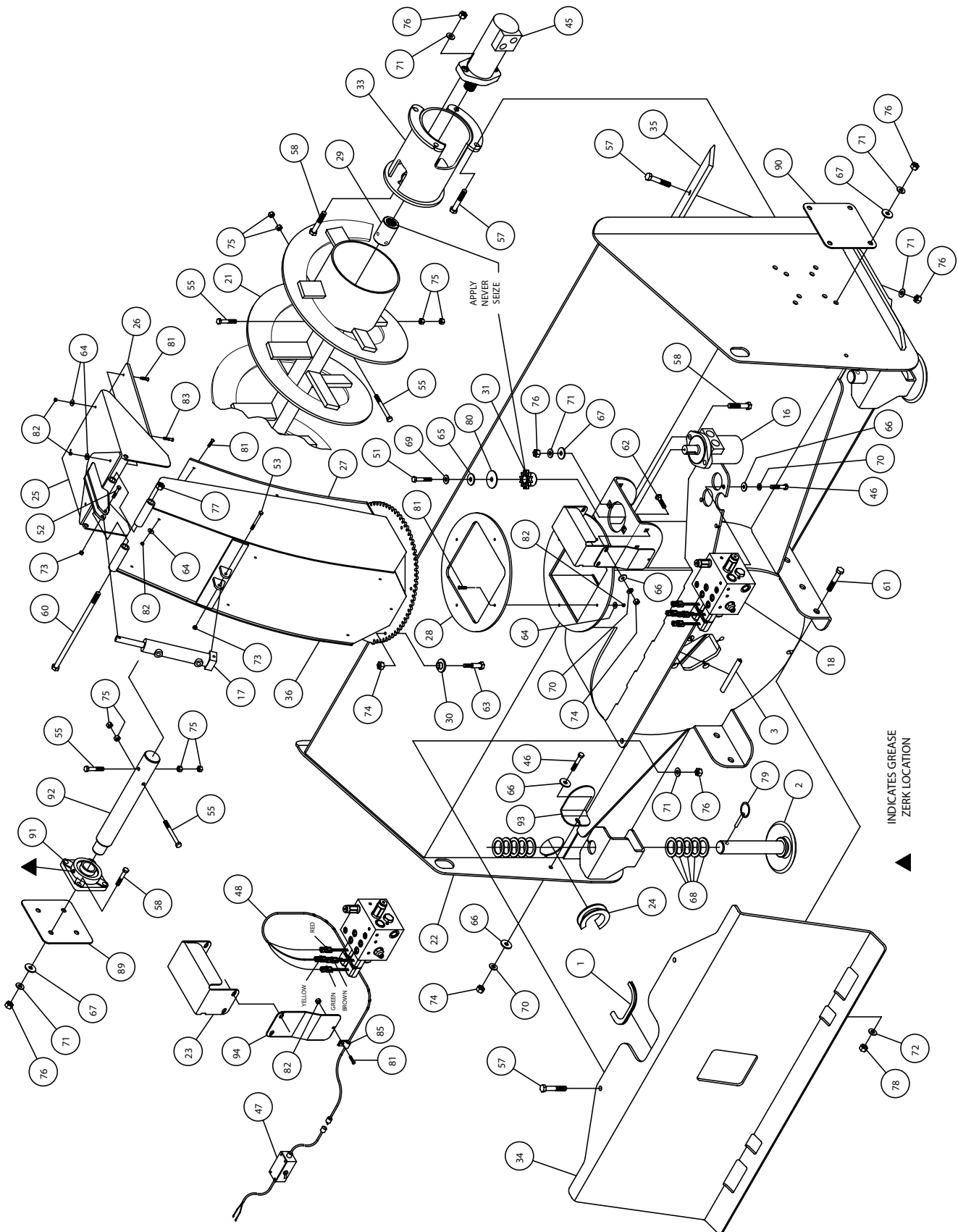

HYDRAULIC/ELECTRIC (High Flow) PARTS ILLUSTRATION

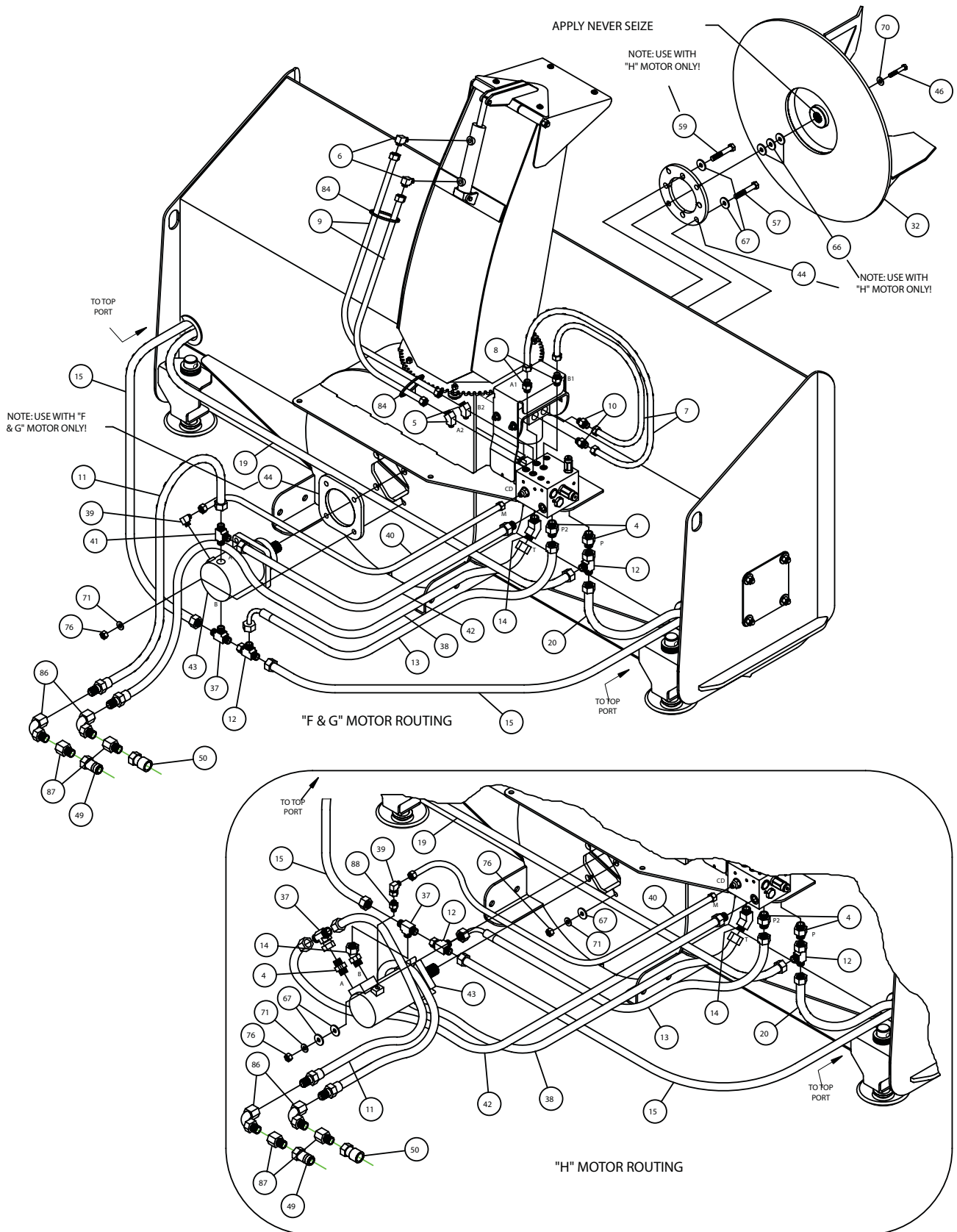

HYDRAULIC SNOW BLOWER (High Flow) PARTS LIST

ITEM	QTY.	LAF6774	11009	LAF6786	LAF6798	DESCRIPTION
		72"	78"	84"	96"	
1	1				LAF1421	Hose Hole Gasket
2	2				LAF1485	Skid Shoe
3	1				LAF3412	Shroud Gusset Protector
4 (F motor)	2	LAF4027	LAF4027	LAF4027	n/a	Hydraulic Adapter: 12MB-12MJ
4 (G motor)	2				LAF4027	Hydraulic Adapter: 12MB-12MJ
4 (H motor)	3				LAF4027	Hydraulic Adapter: 12MB-12MJ
5	2				LAF4246	Hydraulic Elbow: 45°, 6MB-6MJ
6	2				LAF4298	Hydraulic Elbow: 90°, 6MB-6MJ
7	2				LAF4302	Hydraulic Hose: ¼" x 19", 6FJ-6FJ
8	2				LAF4406	Hydraulic Adapter: 6MB-6MJ
9	2				LAF4460	Hydraulic Hose: ¼" x 48-1/2", 6FJ-6FJ
10	2				LAF4679	Hydraulic Adapter: 6MJ-10MB
11	1				LAF4752	Hydraulic Hose: ¾" x 80", 12MB-12FJ
12 (F motor)	1	LAF4755	LAF4755	LAF4755	n/a	Hydraulic Tee: 12MJ-12FJ-12MJ
12 (G & H motor)	2				LAF4755	Hydraulic Tee: 12MJ-12FJ-12MJ
13	1				LAF4756	Hydraulic Hose: ¾" x 30", 12FJ-12FJ90°
14 (F motor)	1					Hydraulic Elbow: 45°, 12MB-12MJ
		LAF4755	LAF4760	LAF4760	n/a	
14 (G motor)	1				LAF4760	Hydraulic Elbow: 45°, 12MB-12MJ
14 (H motor)	2				LAF4760	Hydraulic Elbow: 45°, 12MB-12MJ
15 (F motor)	1	LAF4765 (48")	LAF4763 (54")	LAF4763 (54")	n/a	Hydraulic Hose: 3/4" x Length Noted, 12FJ-10MB
15 (G & H motor)	2	LAF4765 (48")	LAF4763 (54")	LAF4763 (54")	LAF4757 (60")	Hydraulic Hose: 3/4" x Length Noted, 12FJ-10MB
16	1				LAF4776	Motor: Chute Rotation
17	1				LAF4779	Hydraulic Cylinder: 1" Bore, 4" Stroke, ½" Rod
18	1				LAF4780	Hydraulic Manifold: (4) Solenoids
19 (G & H motor)	1	LAF4783 (72")	LAF4764 (78")	LAF4764 (78")	LAF4758 (84")	Hydraulic Hose: 3/4" x Length Noted, 12FJ-10MB
20	1	LAF4784 (26")	LAF4319 (32")	LAF4319 (32")	LAF4759 (38")	Hydraulic Hose: 3/4" x Length Noted, 12FJ-10MB
21	1	LAF6510	13-52893	LAF6512		Auger
					LAF6514	
22	1	LAF6511	13-52890	LAF6513		Main Housing
					LAF6515	
23	1				LAF6516	Chute Motor Guard
24 (F motor)	1					Shroud Gasket Protector
		LAF6517	LAF6517	LAF6517	n/a	
24 (G & H motor)	2				LAF6517	Shroud Gasket Protector
25	1				LAF6527	Deflector
26	1				LAF6551	Deflector Liner
27	1				LAF6565	Chute Liner
28	1				LAF6566	Chute Rotation Pad
29 (F motor)	1					Auger Sleeve
		LAF6567	LAF6567	LAF6567	n/a	
29 (G & H motor)	2				LAF6567	Auger Sleeve
30	6				LAF6568	Chute Retainer Bushing
31	1				LAF6587	Chute Rotation Sprocket
32	1				LAF6592	Fan
33 (F motor)	1					Motor Mount
		LAF6593	LAF6593	LAF6593	n/a	
33 (G & H motor)	2				LAF6593	Motor Mount

NOTE: All parts are the same as the LAF6798 except for those parts numbered under the other models.

HYDRAULIC SNOW BLOWER (High Flow) PARTS LIST (Continued)

ITEM	QTY.	LAF6774 72"	11009 78"	LAF6786 84"	LAF6798 96"	DESCRIPTION
34	1				LAF6594	Loader Attachment Plate
35	1	LAF6595	13-52913	LAF6590	LAF6591	Cutting Edge
36	1				LAF6599	Chute
37 (F motor)	1	LAF4419	LAF4419	LAF4419	n/a	Hydraulic Elbow: 90°, 12MB-12MJ
37 (G motor)	1				LAF4185	Hydraulic Tee: 12MJ-12MJ-12MB
37 (H motor)	2				LAF4761	Hydraulic Tee: 12MJ-12MJ-12FJ
38 (F motor)	1	LAF4518	LAF4518	LAF4518	n/a	Hydraulic Hose: ¾" x 115", 12MB-12FJ
38 (G motor)	1				LAF4518	Hydraulic Hose: ¾" x 115", 12MB-12FJ
38 (H motor)	1				LAF4781	Hydraulic Hose: ¾" x 132", 12MB-12FJ
39 (F motor)	1	LAF4520	LAF4520	LAF4520	n/a	Hydraulic Elbow: 90°, 4MB-6MJ
39 (G motor)	1				LAF4520	Hydraulic Elbow: 90°, 4MB-6MJ
39 (H motor)	1				LAF4093	Hydraulic Elbow: 90°, 6MJ-6FJSW
40 (F motor)	1	LAF4668	LAF4668	LAF4668	n/a	Hydraulic Hose: ¼" x 32-1/2", 6FJ-6FJ
40 (G motor)	1				LAF4668	Hydraulic Hose: ¼" x 32-1/2", 6FJ-6FJ
40 (H motor)	1				LAF4670	Hydraulic Hose: ¼" x 25-1/2", 6FJ-6FJ
41 (F motor)	1	LAF4753	LAF4753	LAF4753	n/a	Hydraulic Tee: 12MJ-12MB-12MJ
41 (G motor)	1				LAF4753	Hydraulic Tee: 12MJ-12MB-12MJ
42 (F motor)	1	LAF4754	LAF4754	LAF4754	n/a	Hydraulic Hose: ½" x 30", 12FJ-8MB
42 (G motor)	1				LAF4754	Hydraulic Hose: ½" x 30", 12FJ-8MB
42 (H motor)	1				LAF4782	Hydraulic Hose: ½" x 48", 12FJ-8MB
43 (F motor)	1	LAF4777	LAF4777	LAF4777	n/a	Fan Motor: "F" & "G"
43 (G motor)	1				LAF4777	Fan Motor: "F" & "G"
43 (H motor)	1				LAF4778	Fan Motor: "H"
44 (F motor)	1	LAF6588	LAF6588	LAF6588	n/a	Motor Mount Plate: "F" & "G" Motor
44 (G motor)	1				LAF6588	Motor Mount Plate: "F" & "G" Motor
44 (H motor)	1				LAF6589	Motor Mount Plate: "H" Motor
45 (F motor)	1	LAF4798	LAF4798	LAF4798	n/a	Auger Motor: "F" & "H"
45 (G motor)	2				LAF9915	Auger Motor: "G"
45 (H motor)	2				LAF4798	Auger Motor: "F" & "H"
46 (F motor)	2	RHW1205	RHW1205	RHW1205	n/a	Grade 5 Hex Head Cap Screw: 3/8" x 1"
46 (G motor)	1				RHW1205	Grade 5 Hex Head Cap Screw: 3/8" x 1"
46 (H motor)	1				RHW1207	Grade 5 Hex Head Cap Screw: 3/8" x 1-1/4"
47	1	Contact FFC to obtain the correct item				Wire Harness with Control Box
48	1				LAF9395	Wire Assembly
49	1	Contact FFC to obtain the correct item				Quick Coupler: Male
50	1	Contact FFC to obtain the correct item				Quick Coupler: Female
51	1				RHW1004	Grade 5 Hex Head Cap Screw: ¼" x ¾"
52	1				RHW1041	Grade 8 Hex Head Cap Screw: ¼" x 2"
53	1				RHW1043	Grade 8 Hex Head Cap Screw: ¼" x 2-1/2"
55	4				RHW1217	Grade 5 Hex Head Cap Screw: 3/8" x 3-1/2"
56	3				RHW1203	Grade 5 Hex Head Cap Screw: 3/8" x ¾"
57 (F motor)	varies	(12)	(12)	(13)	(n/a) RHW1405	Grade 5 Hex Head Cap Screw: ½" x 1-1/2"
57 (G motor)	varies	(16)	(16)	(17)	(18) RHW1405	Grade 5 Hex Head Cap Screw: ½" x 1-1/2"
57 (H motor)	varies	(20)	(20)	(21)	(22) RHW1405	Grade 5 Hex Head Cap Screw: ½" x 1-1/2"
58 (F motor)	8	RHW1406	RHW1406	RHW1406	n/a	Grade 5 Hex Head Cap Screw: ½" x 1-3/4"
58 (G & H motor)	6				RHW1406	Grade 5 Hex Head Cap Screw: ½" x 1-3/4"
59	4				RHW1408	Grade 5 Hex Head Cap Screw: ½" x 2-1/4"
60	1				RHW1430	Grade 5 Hex Head Cap Screw: ½" x 12"

NOTE: All parts are the same as the LAF6798 except for those parts numbered under the other models.

HYDRAULIC SNOW BLOWER (High Flow) PARTS LIST (Continued)

ITEM	QTY.	LAF6774	11009	LAF6786	LAF6798	DESCRIPTION
		72"	78"	84"	96"	
61	4				RHW1604	Grade 5 Hex Head Cap Screw: 5/8" x 2"
62	4				RHW2205	Grade 5 Carriage Bolt: 3/8" x 1"
63	6				RHW4106	Allen Head Shoulder Screw: 1/2" x 3/4" with 3/8"-16 tpi. x 5/8"
64	15				RHW5031	Grade 2 Flat Washer: 3/16", SAE
65	1				RHW5062	Grade 5 Flat Washer: 1/4", USS
66 (F motor)	9	RHW5262	RHW5262	RHW5262	n/a	Grade 5 Flat Washer: 3/8", USS
66 (G motor)	7				RHW5262	Grade 5 Flat Washer: 3/8", USS
66 (H motor)	10				RHW5262	Grade 5 Flat Washer: 3/8", USS
67 (F & G motor)	14				RHW5492	Grade 8 Flat Washer: 1/2", SAE
67 (H motor)	30				RHW5492	Grade 8 Flat Washer: 1/2", SAE
68	24				07-10126	Grade 5 Flat Washer: 1-5/8" SAE
69	1				RHW6002	Grade 5 Lock Washer: 1/4"
70 (F motor)	9	RHW6202	RHW6202	RHW6202	n/a	Grade 5 Lock Washer: 3/8"
70 (G & H motor)	8				RHW6202	Grade 5 Lock Washer: 3/8"
71 (F motor)	varies	(24)	(24)	(25)	(n/a) RHW6402	Grade 5 Lock Washer: 1/2"
71 (G motor)	varies	(26)	(26)	(27)	(28) RHW6402	Grade 5 Lock Washer: 1/2"
71 (H motor)	varies	(30)	(30)	(31)	(32) RHW6402	Grade 5 Lock Washer: 1/2"
72	4				RHW6602	Grade 5 Lock Washer: 5/8"
73	2				RHW7002	Grade 5 Lock Nut: 1/4" (nylock)
74 (F motor)	11	RHW7201	RHW7201	RHW7201	n/a	Grade 5 Hex Nut: 3/8"
74 (G & H motor)	10				RHW7201	Grade 5 Hex Nut: 3/8"
75	8				RHW7203	Grade 5 Lock Nut: 3/8"
76 (F motor)	varies	(24)	(24)	(25)	(n/a) RHW7401	Grade 5 Hex Nut: 1/2"
76 (G motor)	varies	(26)	(26)	(27)	(28) RHW7401	Grade 5 Hex Nut: 1/2"
76 (H motor)	varies	(30)	(30)	(31)	(32) RHW7401	Grade 5 Hex Nut: 1/2"
77	1				RHW7403	Grade 5 Lock Nut: 1/2"
78	4				RHW7601	Grade 5 Hex Nut: 5/8"
79	2				RHW8064	Lynch Pin: 7/16" x 1-5/8"
80	1				RHW8117	Grade 2 Fender Washer: 5/64" x 1/4" x 1-1/2"
81	14				RHW9001	Truss Head Machine Screw: 3/16" x 3/4"
82	16				RHW9002	Grade 2 Lock Nut: 3/16" (nylock)
83	2				RHW9006	Truss Head Machine Screw: 3/16" x 1"
84	8				RMR5002	Wiretie: 1/4" x 6"
85	1				RHW8314	Cable Clip
86	2	Contact FFC to obtain correct item				Hydraulic Elbow (not required on all models)
87	2	Contact FFC to obtain correct item				Hydraulic Adapter (not required on all models)
88 (H motor)	1				LAF4762	Hydraulic Adapter: 4MB-6MJ
89 (F motor)	1	LAF6579	LAF6579	LAF6579	n/a	End Plate Cap f/ Bearing
90 (F motor)	1	LAF6580	LAF6580	LAF6580	n/a	End Plate Cap f/ Motor
90 (G & H motor)	2				LAF6580	End Plate Cap f/ Motor
91 (F motor)	1	LAF6808	LAF6808	LAF6808	n/a	Flange Mount Bearing 1-7/16 ID 4-Bolt
92 (F motor)	1	LAF6569	LAF6569	LAF6569	n/a	Idler Shaft f/ Single Motor
93 (F motor)	1	LAF6570	LAF6570	LAF6570	n/a	Cover f/ Single Motor
94	1				LAF6508	Chute motor guard plate

NOTE: All parts are the same as the LAF6798 except for those parts numbered under the other models.

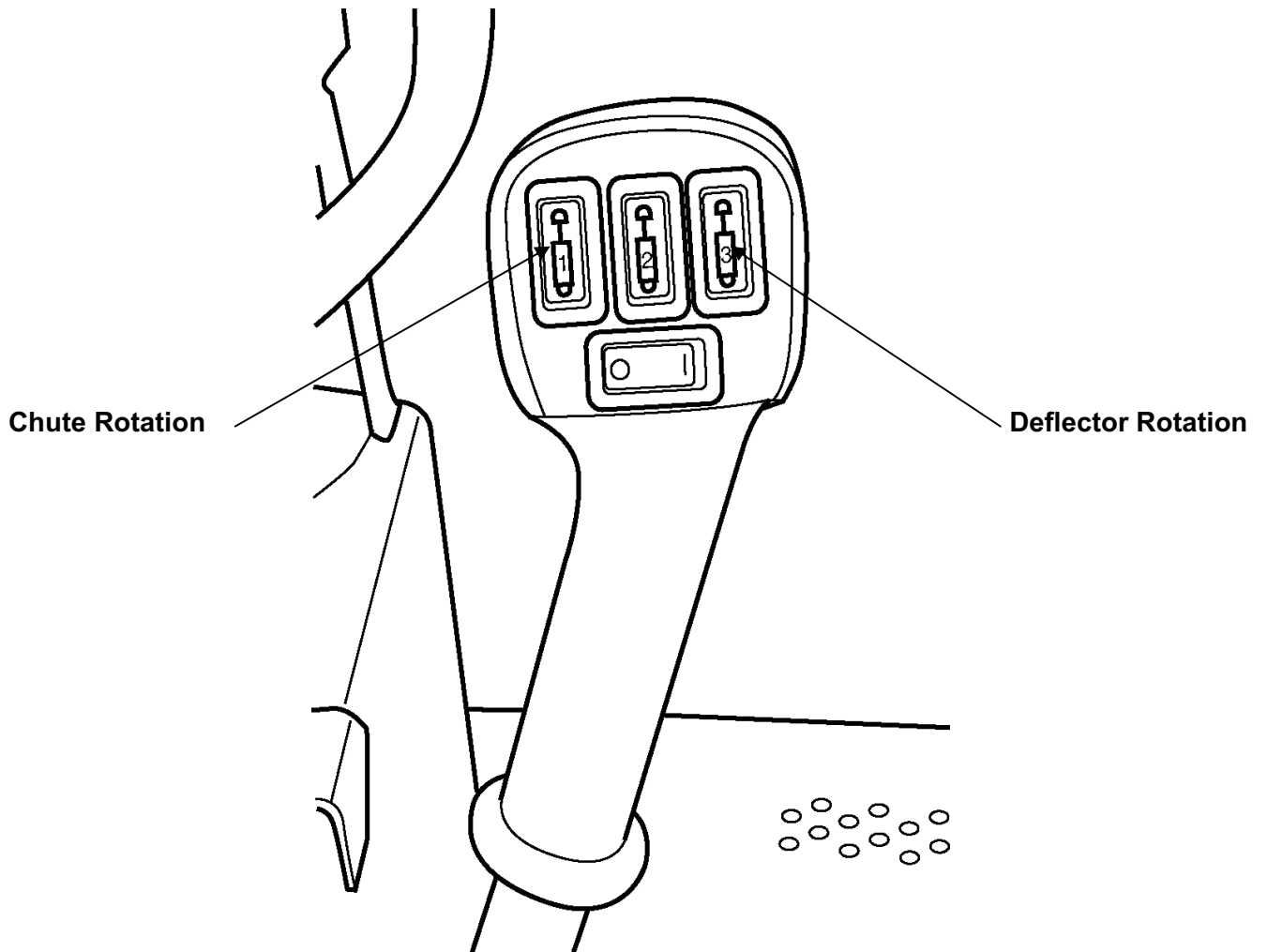

Left hand joy stick for LS160, LS170, LS180, & LS190 New Holland Machines

JD joy stick

**DEFLECTOR
ROTATION**

**CHUTE
ROTATION**

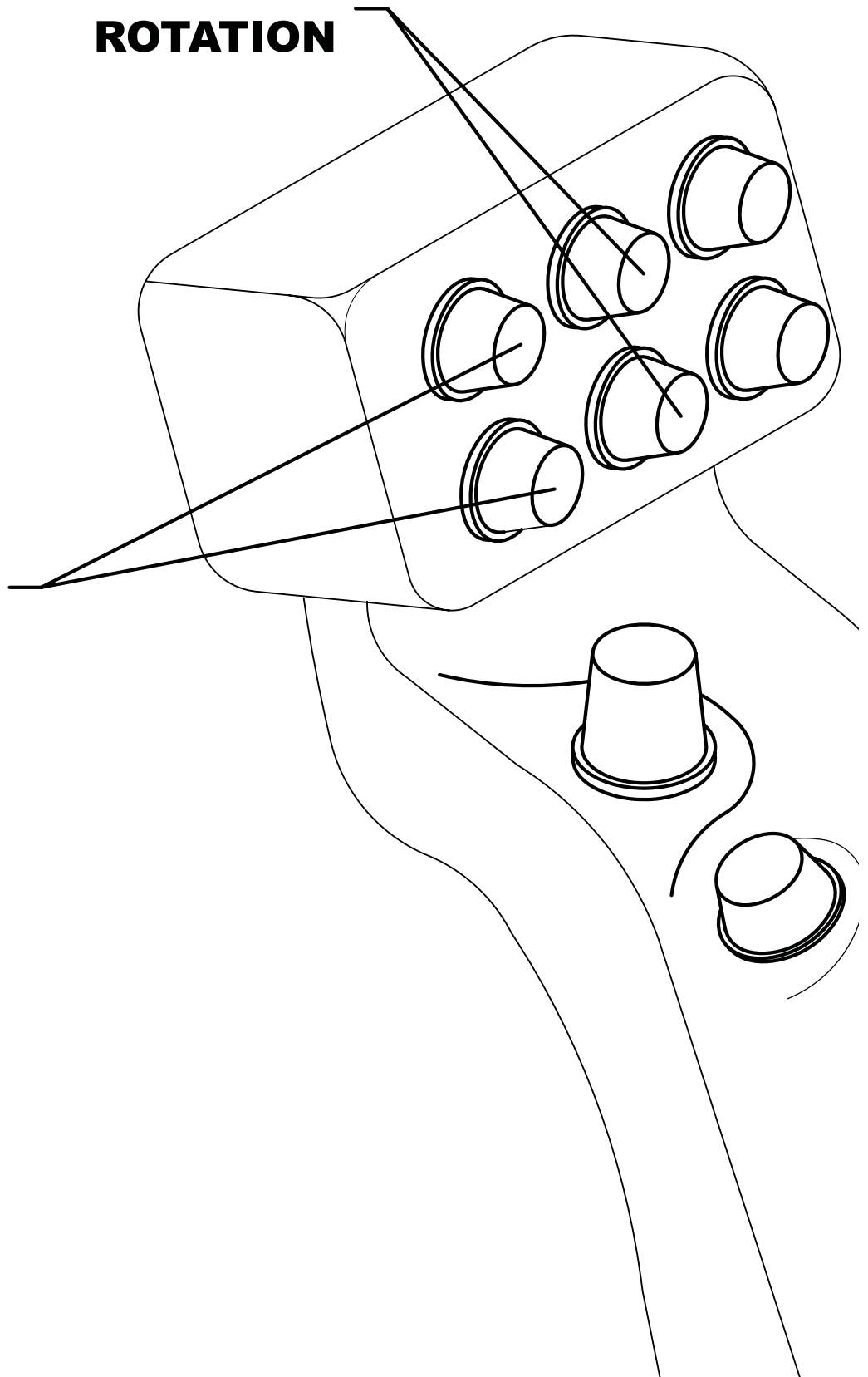



PALADIN LIGHT CONSTRUCTION

Warranty Registration Form and Delivery Inspection Report

IMPORTANT! Warranty **Void** if card is not returned with 10 days.
All Applicable sections **must** be filled in.

This section to be filled out and signed by Dealer at time of delivery.

Warranty Registration

Customer's Name _____	Dealer's Name _____
Address _____	Address _____
City _____ State _____ Zip _____	City _____ State _____ Zip _____
Phone _____	CHECK ONE:
Loader / Tractor Model _____	Construction Use _____
Delivery Date _____	Agricultural Use _____
Model or Part # _____	Landscape Use _____
Serial # _____	Other: _____

Dealer Inspection (check items applicable)

- | | |
|---|---|
| <input type="checkbox"/> All Decals installed (see operator's manual) | <input type="checkbox"/> Review Operating and Safety Instructions |
| <input type="checkbox"/> Hydraulic fittings tight and free of leaks | <input type="checkbox"/> Guards and covers in place and secure |
| <input type="checkbox"/> Fasteners tight | <input type="checkbox"/> Does Product Function Properly |

I have thoroughly instructed the buyer on the above described equipment. This review included: The Operator's manual content, equipment care, adjustments, safe operation and applicable warranty policy.

Date _____ Dealer's Rep. signature _____

This section to be completed and signed by the customer

	1 Excellent	2 Good	3 Average	4 Unsatisfactory	5 Poor
QUALITY ASSURANCE RATING					
Question:		FFC		Local Dealer	
Quality of Product: Appearance		_____		_____	
Construction		_____		_____	
Quality of Service		_____		_____	
Value (Priced Fairly)		_____		_____	
Does it perform as claimed		_____		_____	

The above described equipment and Operator's Manual have been received by me and I have been thoroughly instructed as to care, adjustments, safe operation and applicable warranty policy.

Date: _____ Owner's signature _____

NOTE! Make one copy each for the dealer's and owner's records. Mail original to FFC Attachments.



PALADIN LIGHT CONSTRUCTION

FFC LIMITED 12 MONTH WARRANTY

Thank you for purchasing a FFC product. Warranty protection is valid only when this Warranty Registration is completed and signed by the customer and dealer, and mailed to FFC. I hereby acknowledge that I have received a copy of the owners Limited Warranty and I accept the terms therein.

For a period of 12 months from date of delivery of product to the original user, FFC, warrants each product to be free from manufacturing defects, subject to the limitations contained in this policy.

This warranty does not apply to defect caused, in whole or in part, by unreasonable use while in the possession of the user, including, but not limited to: failure to properly set up product; failure to provide reasonable and necessary maintenance; normal wear; routine tune ups or adjustments; improper handling or accidents; operation at speed or load conditions contrary to published specification; improper or insufficient lubrication; improper storage. This warranty is also not a guarantee that the performance of each product will meet the expectations of the purchaser.

FFC shall not be liable for consequential damages of any kind, including, but not limited to: consequential labor costs or transportation charges in connection with the replacement or repair of defective parts; lost time or expense which may have accrued because of said defects. In no event shall FFC, Inc.'s total liability hereunder exceed the product purchase price.

FFC makes no warranty with respect to trade accessories or any component or accessory of the product which was not manufactured by FFC, including any purchased components on any kind. These are subject to the warranties of their respective manufacturers. The warranty will be considered void if the product or any part of the product is modified or repaired in any way not expressly authorized by FFC, or if closed components are disassembled prior to return. Closed components include, but are not limited to: gearboxes, hydraulic pumps, motors, cylinders, and actuators.

Our obligation under the warranty is expressly limited, at our option, to the replacement or repair at FFC, of Lee, Illinois, or at a service facility designated by us, or such part or parts as inspection shall disclosed to have been defective. We are not responsible for unauthorized repairs or replacements. Any implied or statutory warranties, including any warranty of merchantability or fitness for a particular purpose, are expressly limited to the duration of this written warranty. We make no other express or implied warranty, nor is anyone authorized to make any in our behalf. This warranty cannot be extended, broadened, or changed except in writing by an authorized officer of FFC.