



# OPERATOR'S & PARTS MANUAL

## BALE SQUEEZE



PALADIN LIGHT CONSTRUCTION

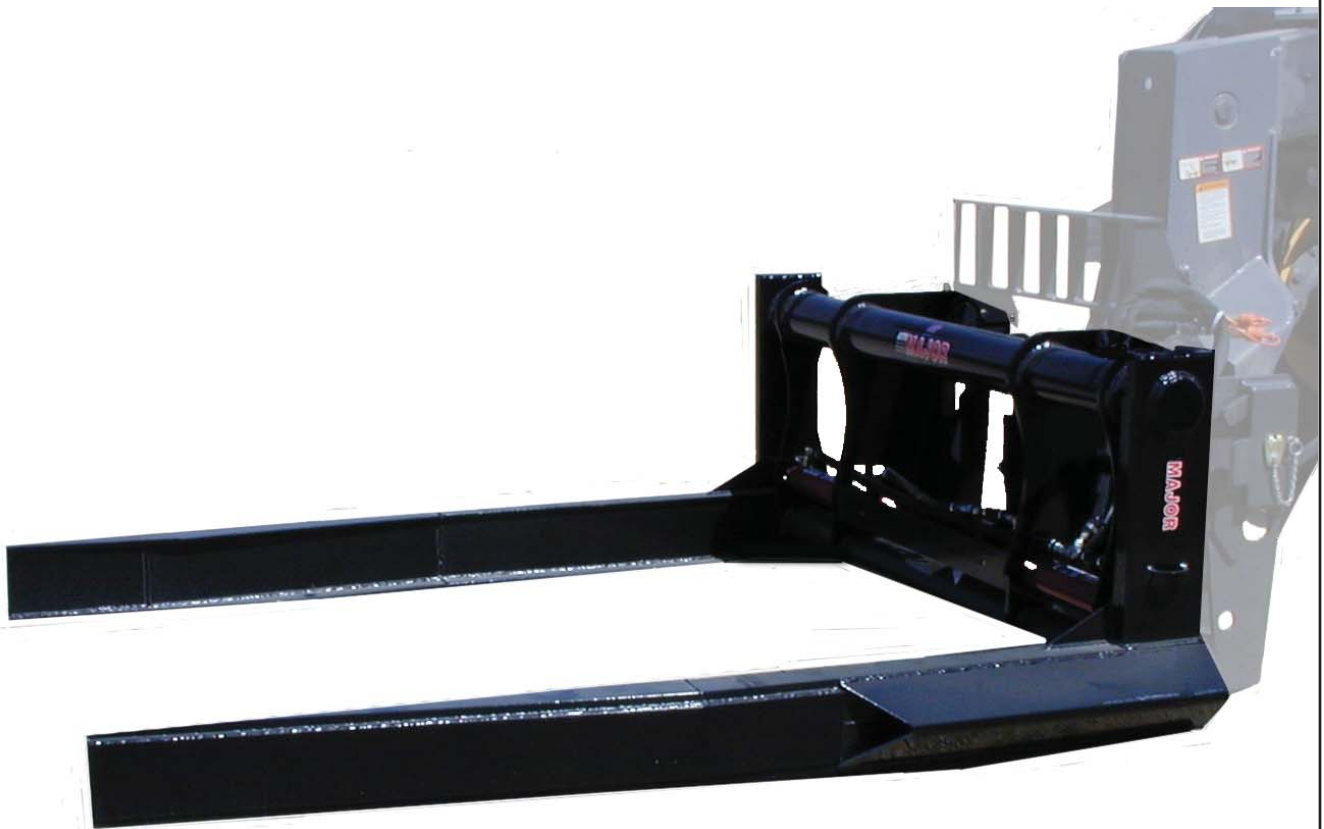

SERIAL NUMBER: \_\_\_\_\_

MODEL NUMBER: \_\_\_\_\_

Manual Number: 76803

Part Number: 76803

Date: December 28, 2006



# TABLE OF CONTENTS

<b>PREFACE.....</b>	<b>3</b>
<b>SAFETY PRECAUTIONS .....</b>	<b>4-8</b>
SAFETY STATEMENTS .....	4
GENERAL SAFETY PRECAUTIONS.....	4-6
EQUIPMENT SAFETY PRECAUTIONS.....	7
<b>INSTALLATION AND OPERATION.....</b>	<b>9-10</b>
ATTACHING AND DETACHING EQUIPMENT .....	9
OPERATING EQUIPMENT.....	9
<b>MAINTENANCE AND SERVICE.....</b>	<b>11-14</b>
<b>STORAGE.....</b>	<b>15</b>
<b>LIMITED WARRANTY .....</b>	<b>17</b>
<b>PARTS</b>	
BALE SQUEEZE ASSEMBLY #12354.....	20-23
CYLINDER ASSEMBLY #100051 .....	24-25

## FOREWORD

Although The Major has various bale squeezes available, we are continually designing new sizes and mountings. If your combination is not listed, please contact the factory. We have extensive mounting information available to generate the product you need.

Below is a listing of the bale squeeze assemblies that are available. See the "Parts" section of this manual for the assemblies "Shown".

<b>DESCRIPTION &amp; MOUNT</b>	<b>ASSEMBLY #</b>
<b>JCB</b>	
110" Bale Squeeze - JCB Q-FIT (Shown)	12354
<b>NEW HOLLAND</b>	
110" Bale Squeeze - NEW HOLLAND-VERSATTACH (Shown)	12354

# PREFACE

## GENERAL COMMENTS

Congratulations on the purchase of your new attachment! This product was carefully designed and manufactured to give you many years of dependable service. Only minor maintenance, such as cleaning and lubricating, is required to keep it in top working condition. Be sure to observe all maintenance procedures and safety precautions in this manual and on any safety decals located on the product, and on any equipment on which the attachment is mounted. Also, check load charts before operating the attachment.

This manual has been designed to help you do a better, safer job. Read this manual carefully and become familiar with its contents.

**WARNING!** Never let anyone operate this unit without reading the “Safety Precautions” and “Operating Instructions” sections of this manual.



**Always choose hard, level ground to park the vehicle on, and set the brake so the unit cannot roll.**

Unless noted otherwise, right and left sides are determined from the operator’s control position when facing the attachment.

**NOTE:** The illustrations and data used in this manual were current, according to the information available to us at the time of printing. However, we reserve the right to redesign and change the attachment as may be necessary, without notification.

## BEFORE OPERATION

The primary responsibility for safety with this equipment falls to the operator. Make sure the equipment is operated only by trained individuals who have read and understand this manual. If there is any portion of this manual or function that you do not understand, contact your local authorized dealer or the manufacturer.

## SAFETY ALERT SYMBOL



This is the “Safety Alert Symbol” used by this industry. This symbol is used to warn of possible injury. Be sure to read all warnings carefully. They are included for your safety and for the safety of others working with you.

## SERVICE

When servicing your product, remember to use only manufacturer replacement parts. Substitute parts may not meet the standards required for safe, dependable operation.

To facilitate parts ordering, record the model and serial number of your unit in the space provided on the cover of this manual. This information may be obtained from the identification plate located on the product.

The parts department needs this information to ensure that you receive the correct parts for your specific model.

# SAFETY STATEMENTS



THIS SYMBOL BY ITSELF OR WITH A WARNING WORD THROUGHOUT THIS MANUAL IS USED TO CALL YOUR ATTENTION TO INSTRUCTIONS INVOLVING YOUR PERSONAL SAFETY OR THE SAFETY OF OTHERS. FAILURE TO FOLLOW THESE INSTRUCTIONS CAN RESULT IN INJURY OR DEATH.



## DANGER

THIS SIGNAL WORD IS USED WHERE SERIOUS INJURY OR DEATH WILL RESULT IF THE INSTRUCTIONS ARE NOT FOLLOWED PROPERLY.



## WARNING

THIS SIGNAL WORD IS USED WHERE SERIOUS INJURY OR DEATH COULD RESULT IF THE INSTRUCTIONS ARE NOT FOLLOWED PROPERLY.



## CAUTION

THIS SIGNAL WORD IS USED WHERE MINOR INJURY COULD RESULT IF THE INSTRUCTIONS ARE NOT FOLLOWED PROPERLY.

## NOTICE

NOTICE INDICATES A PROPERTY DAMAGE MESSAGE.

## GENERAL SAFETY PRECAUTIONS

### WARNING!

#### READ MANUAL PRIOR TO INSTALLATION



Improper installation, operation, or maintenance of this equipment could result in serious injury or death. Operators and maintenance personnel should read this manual, as well as all manuals related to this equipment and the prime mover thoroughly before beginning installation, operation, or maintenance. **FOLLOW ALL SAFETY INSTRUCTIONS IN THIS MANUAL AND THE PRIME MOVER'S MANUAL(S).**



#### READ AND UNDERSTAND ALL SAFETY STATEMENTS

Read all safety decals and safety statements in all manuals prior to operating or working on this equipment. Know and obey all OSHA regulations, local laws, and other professional guidelines for your operation. Know and follow good work practices when assembling, maintaining, repairing, mounting, removing, or operating this equipment.



#### KNOW YOUR EQUIPMENT

Know your equipment's capabilities, dimensions, and operations before operating. Visually inspect your equipment before you start, and never operate equipment that is not in proper working order with all safety devices intact. Check all hardware to ensure it is tight. Make certain that all locking pins, latches, and connection devices are properly installed and secured. Remove and replace any damaged, fatigued, or excessively worn parts. Make certain all safety decals are in place and are legible. Keep decals clean, and replace them if they become worn or hard to read.

## GENERAL SAFETY PRECAUTIONS

### WARNING!



#### PROTECT AGAINST FLYING DEBRIS

Always wear proper safety glasses, goggles, or a face shield when driving pins in or out, or when any operation causes dust, flying debris, or any other hazardous material.

### WARNING!



#### LOWER OR SUPPORT RAISED EQUIPMENT

Do not work under raised booms without supporting them. Do not use support material made of concrete blocks, logs, buckets, barrels, or any other material that could suddenly collapse or shift positions. Make sure support material is solid, not decayed, warped, twisted, or tapered. Lower booms to ground level or on blocks. Lower booms and attachments to the ground before leaving the cab or operator's station.

### WARNING!



#### USE CARE WITH HYDRAULIC FLUID PRESSURE

Hydraulic fluid under pressure can penetrate the skin and cause serious injury or death. Hydraulic leaks under pressure may not be visible. Before connecting or disconnecting hydraulic hoses, read your prime mover's operator's manual for detailed instructions on connecting and disconnecting hydraulic hoses or fittings.

- Keep unprotected body parts, such as face, eyes, and arms as far away as possible from a suspected leak. Flesh injected with hydraulic fluid may develop gangrene or other permanent disabilities.
- If injured by injected fluid, see a doctor at once. If your doctor is not familiar with this type of injury, ask him to research it immediately to determine proper treatment.
- Wear safety glasses, protective clothing, and use a piece of cardboard or wood when searching for hydraulic leaks. **DO NOT USE YOUR HANDS! SEE ILLUSTRATION.**

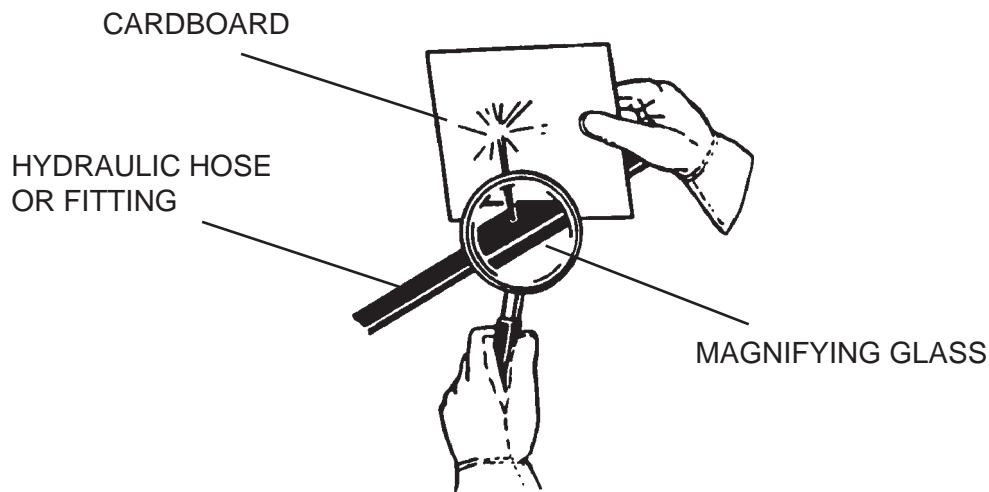

M-807 7-28-05-2

# GENERAL SAFETY PRECAUTIONS

## WARNING!



### DO NOT MODIFY MACHINE OR ATTACHMENTS

Modifications may weaken the integrity of the attachment and may impair the function, safety, life, and performance of the attachment. When making repairs, use only the manufacturer's genuine parts, following authorized instructions. Other parts may be substandard in fit and quality. Never modify any ROPS (Roll Over Protection Structure) or FOPS (Falling Object Protective Structure) equipment or device. Any modifications must be authorized in writing by the manufacturer.

## WARNING!



### SAFELY MAINTAIN AND REPAIR EQUIPMENT

- Do not wear loose clothing or any accessories that can catch in moving parts. If you have long hair, cover or secure it so that it does not become entangled in the equipment.
- Work on a level surface in a well-lit area.
- Use properly grounded electrical outlets and tools.
- Use the correct tools for the job at hand. Make sure they are in good condition for the task required.
- Wear the protective equipment specified by the tool manufacturer.



### SAFELY OPERATE EQUIPMENT

Do not operate equipment until you are completely trained by a qualified operator in how to use the controls, know its capabilities, dimensions, and all safety requirements. See your machine's manual for these instructions.

- Keep all step plates, grab bars, pedals, and controls free of dirt, grease, debris, and oil.
- Never allow anyone to be around the equipment when it is operating.
- Do not allow riders on the attachment or the prime mover.
- Do not operate the equipment from anywhere other than the correct operator's position.
- Never leave equipment unattended with the engine running, or with this attachment in a raised position.
- Do not alter or remove any safety feature from the prime mover or this attachment.
- Know your work site safety rules as well as traffic rules and flow. When in doubt on any safety issue, contact your supervisor or safety coordinator for an explanation.

# EQUIPMENT SAFETY PRECAUTIONS

## WARNING!



### KNOW WHERE UTILITIES ARE

Observe overhead electrical and other utility lines. Be sure equipment will clear them. When digging, call your local utilities for location of buried utility lines, gas, water, and sewer, as well as any other hazard you may encounter.



### OPERATING THE PRIME MOVER

Avoid steep hillside operation, which could cause the prime mover to overturn. Consult your prime mover operator's and safety manuals for maximum incline allowable. Extreme caution should be used when working along the top of banks or slopes. Keep away from the edge.

When operating on a slope, keep the load low, and proceed with extreme caution. Do not drive ACROSS a steep slope - drive straight up and down. With a LOADED attachment - face the attachment and load uphill. With an EMPTY attachment - face the attachment downhill.



### WORKING WITH THE BALE SQUEEZE

- Never use your attachment for a work platform or personnel carrier.
- Only carry the quantity of bales that your particular bale squeeze was designed for.
- Do not transport stacks of bales.
- Specified lift capacities must not be exceeded, otherwise machine stability is not sufficient. Always observe lift capacity limits listed in machine specifications.
- An operator must not use drugs or alcohol, which can change his or her alertness or coordination. An operator taking prescription or over-the-counter drugs should seek medical advice on whether or not he or she can safely operate equipment.
- Always check locking pins before operating any attachment.
- Never lift, move, or swing a bale over anyone.
- Don't obstruct your vision when traveling or working. Carry the attachment low for maximum stability and visibility.
- Never stack loads on uneven ground. Loads stacked on uneven ground can topple.
- Grab bales 1/3 to 1/2 the way up from the bottom edge of bale.



# INSTALLATION AND OPERATION

## ATTACHING AND DETACHING EQUIPMENT

Please see your vehicle operator's manual for instructions on attaching and detaching your equipment.

### **WARNING!**



To prevent serious personal injury or death, only attach equipment that is designed for your prime mover.

Specified lift capacities must not be exceeded, otherwise machine stability will not be sufficient. Always observe lift capacity limits listed in machine specifications.

## OPERATING EQUIPMENT

Read all Safety Precautions before operating your new attachment.

Grab bales 1/3 to 1/2 of the way up from the bottom edge of the bale.

Do not raise bale(s) too high. Vehicle stability may be affected if bales are carried at raised heights. Lifting too high or rolling the attachment too far back could result in objects sliding backward down the arms onto the operator compartment.

Only carry the quantity of bales that your particular bale squeeze was designed for. Do not transport more bales than your attachment was designed to lift.

When transporting bale(s), carry them as low to the ground as possible.

Do not stack bales on uneven ground. Bales stacked on uneven ground can topple. Be sure when stacking bales that the load heights do not exceed the lifting capabilities of your handling equipment.

For personal safety, lower the attachment to the ground, set the parking brake, shut off engine, and remove key before getting off of your prime mover.



# MAINTENANCE & SERVICE

## GENERAL INFORMATION

Regular maintenance is the key to long equipment life and safe operation. Maintenance requirements have been kept to an absolute minimum. However, it is very important that these maintenance functions be performed as described in this section.

### DAILY

- Check all bolts and nuts for tightness.
- Replace any missing bolts or nuts with approved replacement parts.
- Check hydraulic system for hydraulic oil leaks. See procedure below.
- Visually inspect the machine for worn parts or cracked welds, and repair as necessary.

**WARNING!** Escaping fluid under pressure can have sufficient force to penetrate the skin, causing serious personal injury. Fluid escaping from a very small hole can be almost invisible. Use a piece of cardboard or wood, rather than hands to search for suspected leaks.



Keep unprotected body parts, such as face, eyes, and arms as far away as possible from a suspected leak. Flesh injected with hydraulic fluid may develop gangrene or other permanent disabilities.

If injured by injected fluid, see a doctor at once. If your doctor is not familiar with this type of injury, ask him or her to research it immediately to determine proper treatment.

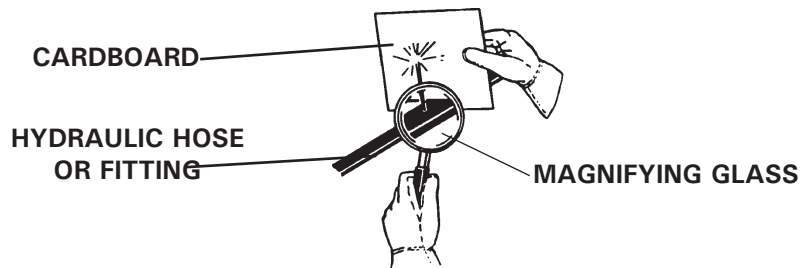

**IMPORTANT:** When replacing parts, use only factory approved replacement parts. Manufacturer will not claim responsibility for use of unapproved parts or accessories and/or other damages as a result of their use.

### EVERY 40 HOURS

Lubrication is an important part of maintenance. It is recommended that all grease fittings be lubricated after the initial 8 hours of operation, and then after every 40 hours of use.

# MAINTENANCE AND SERVICE

## CYLINDER SEAL REPLACEMENT

The following information is provided to assist you in the event you should need to repair or rebuild a hydraulic cylinder. When working on hydraulic cylinders, make sure that the work area and tools are clean and free of dirt to prevent contamination of the hydraulic system and damage to the hydraulic cylinders. Always protect the active part of the cylinder rod (the chrome section). Nicks or scratches on the surface of the rod could result in cylinder failure. Clean all parts thoroughly with a cleaning solvent before reassembly.

### DISASSEMBLY PROCEDURE

**IMPORTANT:** Do not contact the active surface of the cylinder rod with the vise. Damage to the rod could result.

#### THREADED TYPE GLAND

1. Rotate the gland with a spanner wrench counterclockwise until the gland is free of the cylinder tube.
2. Pull the cylinder rod from the cylinder tube and inspect the piston and the bore of the cylinder tube for deep scratches or galling. If damaged, the piston AND the cylinder tube must be replaced.

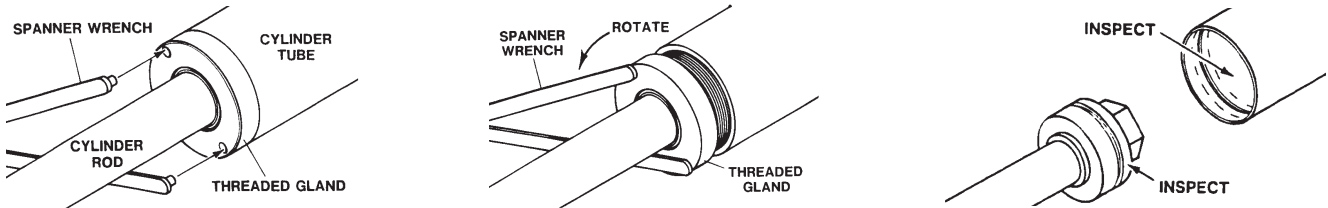

3. Remove the hex nut, piston, flat washer or spacer tube (if so equipped), and gland from the cylinder rod. If the cylinder rod is rusty, scratched, or bent, it must be replaced.
4. Remove and discard all the old seals.



#### ASSEMBLY PROCEDURE

**IMPORTANT:** Replace all seals even if they do not appear to be damaged. Failure to replace all seals may result in premature cylinder failure. **NOTE:** Seal kits will service most cylinders of similar bore size and rod diameter.

1. Install the cylinder rod seal in the gland first. Be careful not to damage the seal in the process, as it is somewhat difficult to install.

**NOTE:** A special installation tool (Part #65349) is available to help with installing the seal. Simply fit the end of the tool over the seal so that the large prong of the tool is on the outside of the seal, and the two smaller prongs on the inside. The lip of the seal should be facing towards the tool. Rotate the handles on the tool around to wrap the seal around the end of the tool.

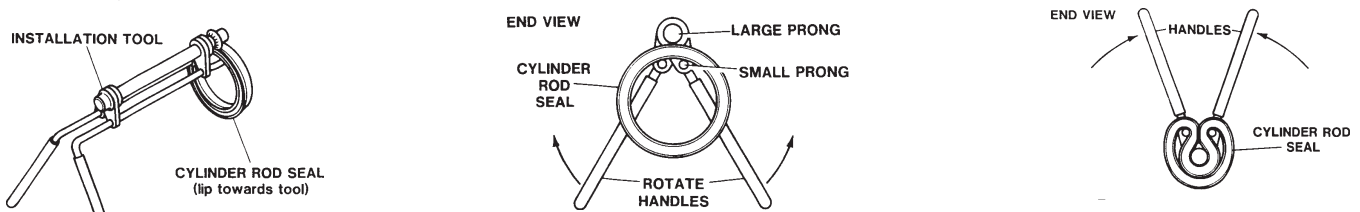

10356 10-13-05

# MAINTENANCE AND SERVICE

Now insert the seal into the gland from the inner end. Position the seal in its groove, and release and remove the tool. Press the seal into its seat the rest of the way by hand.

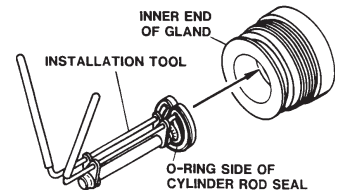

2. Install the new piston ring, rod wiper, O-rings and backup washers, if applicable, on the piston.

Be careful not to damage the seals. Caution must be used when installing the piston ring. The ring must be stretched carefully over the piston with a smooth, round, pointed tool.

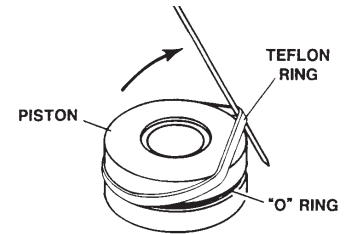

3. After installing the rod seal inside the gland, as shown in step #1, install the external seal.

**NOTE:** Threaded glands may have been equipped with a separate O-ring and backup washer system or a polypak (all in one) type seal. Current seal kits contain a polypak (all in one) type seal to replace the discarded seal types on ALL THREADED GLANDS.

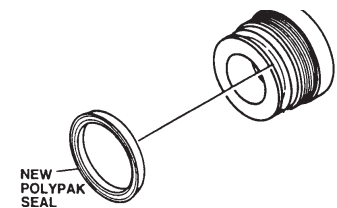

4. Slide the gland onto the cylinder rod, being careful not to damage the rod wiper. Then install the spacer, or flat washer (if so equipped), small o-ring, piston, and hex nut onto the end of the cylinder rod.
5. Secure the cylinder rod (mounting end) in a vise with a support at its center. Torque the nut to the amount shown for the thread diameter of the cylinder rod (see chart).

Thread Diameter	POUNDS - FEET
7/8"	150-200
*1"	230-325
1-1/8"	350-480
1-1/4"	490-670
1-3/8"	670-900
<b>* 1" Thread Diameter WITH 1.25" Rod Diameter</b> <b>Min. 230 ft. lbs. Max. 250 ft. lbs.</b>	

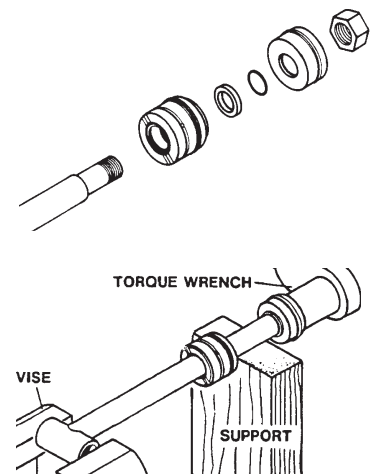

**IMPORTANT:** Do not contact the active surface of the cylinder rod with the vise. Damage to the rod could result.

6. Apply a lubricant (such as Lubriplate #105) to the piston and teflon ring. Insert the cylinder rod assembly into the cylinder tube.

**IMPORTANT:** Ensure that the piston ring fits squarely into the cylinder tube and piston groove, otherwise the ring may be damaged and a leak will occur.

7. Use a spanner wrench to rotate the gland clockwise into the cylinder. Continue to rotate the gland with the spanner wrench until it is tight.

**WARNING!** Cylinders serviced in the field are to be tested for leakage prior to the attachment being placed in work. Failure to test rebuilt cylinders could result in damage to the cylinder and/or the attachment, cause severe personal injury or even death.





# STORAGE

## GENERAL INFORMATION

The following storage procedure will help you to keep your attachment in top condition. It will also help you get off to a good start the next time your equipment is needed. We therefore strongly recommend that you take the extra time to follow these procedures whenever your attachment will not be used for an extended period of time.

## PREPARATION FOR STORAGE

1. Clean the attachment thoroughly, removing all mud, dirt, and grease.
2. Inspect for visible signs of wear, breakage, or damage. Order any parts required, and make the necessary repairs, to avoid delays when starting next season.
3. Tighten all loose nuts, capscrews, and hydraulic connections.
4. Lubricate all grease fittings.
5. Coat the exposed portions of the cylinder rods with grease.
6. Connect the hydraulic couplers together to protect the hydraulic system from contaminants.
7. Touch up all unpainted and exposed areas with paint, to prevent rust.
8. Replace decals, if damaged or in unreadable condition.
9. Store the attachment in a dry and protected place, with a cover, if possible. Leaving the attachment outside will materially shorten its life.

## REMOVING FROM STORAGE

1. Remove all protective coverings.
2. Check hydraulic hoses for deterioration, and replace if necessary.



## LIMITED WARRANTY

All new Major products are warranted to be free from defects in materials or workmanship which may cause failure under normal usage and service, when used for the purpose intended.

In the event of failure within twelve (12) months from initial retail sale, lease or rental date (excluding cable, ground engaging parts such as sprockets, digging chain, bearings, teeth, tamping and demolition heads, blade cutting edges, pilot bits, auger teeth, auger heads & broom bristles), if after examination, The Major determines failure was due to defective material and/or workmanship, parts will be repaired or replaced. The Major may request defective part or parts be returned prepaid to them for inspection at their place of business at Delhi, Iowa, or to a location specified by The Major.

Any claims under this warranty must be made within fifteen (15) days after the Buyer learns of the facts upon which such claim is based. All claims not made in writing and received by The Major within the time period specified above shall be deemed waived.

**THIS WARRANTY IS IN LIEU OF ALL OTHER WARRANTIES EXPRESSED OR IMPLIED, AND THERE ARE NO WARRANTIES OF MERCHANTABILITY OR OF FITNESS FOR A PARTICULAR PURPOSE. IN NO EVENT SHALL THE MAJOR BE LIABLE FOR CONSEQUENTIAL OR SPECIAL DAMAGE.**

**THE MAJOR'S LIABILITY FOR ANY AND ALL LOSSES AND DAMAGES TO BUYER, RESULTING FROM ANY CAUSE WHATSOEVER, INCLUDING THE MAJOR'S NEGLIGENCE, IRRESPECTIVE OF WHETHER SUCH DEFECTS ARE DISCOVERABLE OR LATENT, SHALL IN NO EVENT EXCEED THE PURCHASE PRICE OF THE PARTICULAR PRODUCTS WITH RESPECT TO WHICH LOSSES OR DAMAGES ARE CLAIMED, OR, AT THE ELECTION OF THE MAJOR, THE REPAIR OR REPLACEMENT OF DEFECTIVE OR DAMAGED PRODUCTS.**



## PARTS

The following section contains detailed diagrams and parts lists which include your attachment. Please use these diagrams and parts lists to locate replacement parts, prior to contacting the parts department.

When servicing your attachment, remember to use only original manufacturer replacement parts. Substitute parts may not meet the standards required for safe, dependable operation.

To facilitate parts ordering, have the model and serial number of your product ready, to ensure that you receive the correct parts for your specific attachment.

The model and serial number for your attachment should be recorded in the space provided on the cover of this manual. This information may be obtained from the serial number identification plate located on your attachment. **See the parts diagram for your attachment for the location.**

**NOTE: Most daily and emergency orders received by 2:00 P.M. will be shipped the same day received, with “Emergency-Machine-Down” orders receiving first priority.**



### PARTS DEPARTMENT

(563) 922-2981

(800) 922-2981

We Encourage Fax Orders

(563) 922-2593

M-1127 10-4-06-2

# BALE SQUEEZE

110" WIDE - ASSEMBLY #12354

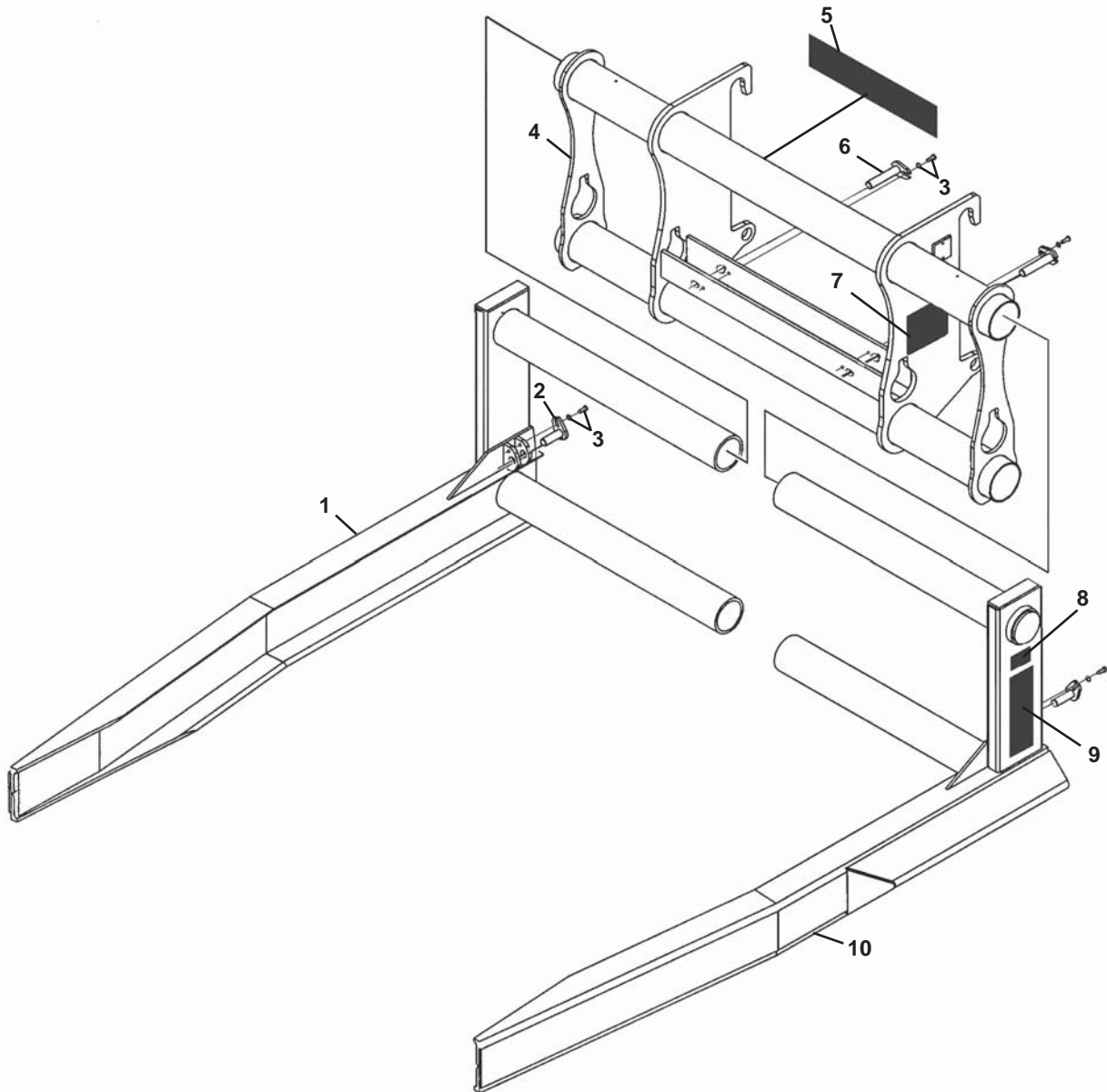
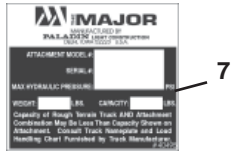

M-1392 1-2-07

**BALE SQUEEZE**  
110" WIDE - ASSEMBLY #12354

<u>ITEM</u>	<u>QTY.</u>	<u>PART NO.</u>	<u>DESCRIPTION</u>
1	1	32421	Right Bale Arm
2	2	31991	Pin, 1.00" x 3.00"
3	4	1503	.38" Lock Washer
	4	1043	.38" UNC x 1.00" Hex Capscrew
4	1	15351	Main Frame
5	1	40502	Major Logo, Medium
6	2	32392	Pin, 1.00" x 5.06"
7	1	-----	Serial Number Identification Tag Location
8	1	4338	Made in USA Decal
9	2	40501	Major Logo, Small
10	1	32422	Left Bale Arm

# BALE SQUEEZE - HYDRAULICS

110" WIDE - ASSEMBLY #12354

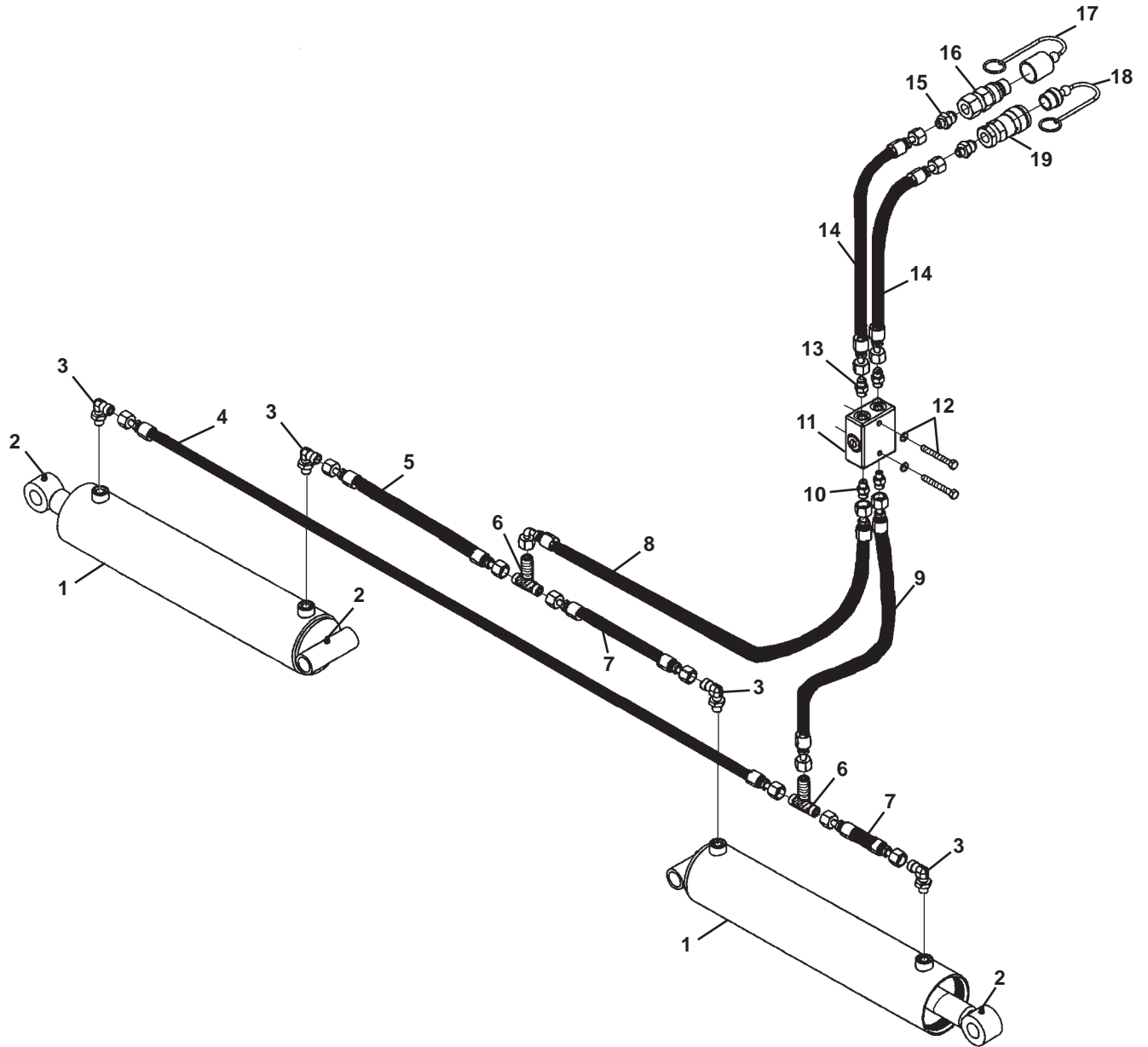

# BALE SQUEEZE - HYDRAULICS

110" WIDE - ASSEMBLY #12354

<u>ITEM</u>	<u>QTY.</u>	<u>PART NO.</u>	<u>DESCRIPTION</u>
1	2	100051	Cylinder Assembly
2	4	6616	Grease Zerk
3	4	30204	90° Elbow, 6MBo-6MFS
4	1	37876	Hose, .38" x 59.00", 6FFS-6FFS
5	1	37841	Hose, .38" x 22.00", 6FFS-6FFS
6	2	30203	Tee, 6MFS x 6MFS x 6MFS
7	2	37873	Hose, .38" x 6.00", 6FFS-6FFS
8	1	37898	Hose, .38" x 33.00", 6FFS-6FFS 90°
9	1	37874	Hose, .38" x 14.00", 6FFS-6FFS
10	2	30208	Straight Connector, 6MBo-6MFF
11	1	88536	Check Valve
12	2	1026	.31" UNC x 2.00" Hex Capscrew
	2	1502	.31" Lock Washer
13	2	3457	Straight Connector, 6MBo-6MJ
14	2	37896	Hose, .38" x 52.00", 6FJX-6FJX
15	2	3269	Straight Connector, 8MBo-6MJ
16	1	84923	Male Quick Coupler
17	1	32549	Dust Cover
18	1	32548	Dust Plug
19	1	84928	Female Quick Coupler

M-1409 1-2-07

# CYLINDER ASSEMBLY

ASSEMBLY #100051

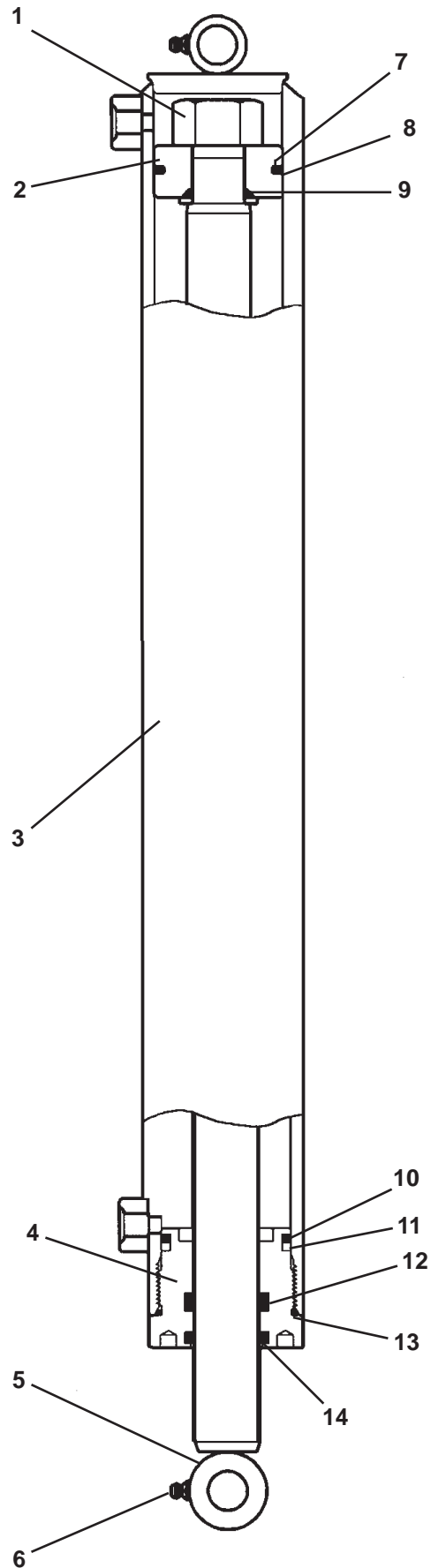

M-1394 11-7-06

# CYLINDER ASSEMBLY

ASSEMBLY #100051

<u>ITEM</u>	<u>QTY.</u>	<u>PART NO.</u>	<u>DESCRIPTION</u>
1	1	1483	Hex Nut
2	1	18440	Piston
3	1	18434	Cylinder Tube
4	1	18433	Cylinder Gland
5	1	18437	Cylinder Rod
6	2	6616	Grease Zerk
7	1	45245*	O-Ring
8	1	45244*	Piston Ring
9	1	4641*	O-Ring
10	1	45242*	O-Ring
11	1	45243*	Back-Up Washer
12	1	45225*	Poly-Pak Seal
13	1	45412*	O-Ring
14	1	45372*	Rod Wiper

**NOTE:** Seal Kit #45821 includes all parts marked with an asterisk (\*). Parts are not sold separately.

M-1395 11-7-06



**P.O. Box 266  
Delhi, IA 52223-0266**

**(563) 922-2981  
(800) 922-2981**

[www.paladinbrands.com](http://www.paladinbrands.com)

M-1360 10-4-06