



OPERATOR'S & PARTS MANUAL

48.00" - 59.00" FLOATING PIN FORK CARRIAGE



PALADIN LIGHT CONSTRUCTION



SERIAL NUMBER: _____

MODEL NUMBER: _____

Manual Number: 76822

Part Number: 76822

Date: November 14, 2006

TABLE OF CONTENTS

| | |
|--|------------|
| PREFACE | 3 |
| SAFETY PRECAUTIONS | 4-7 |
| SAFETY STATEMENTS | 4 |
| GENERAL SAFETY PRECAUTIONS..... | 4-6 |
| EQUIPMENT SAFETY PRECAUTIONS | 7 |
| INSTALLATION AND OPERATION | 8 |
| ATTACHING & DETACHING | 8 |
| OPERATING EQUIPMENT | 8 |
| STORAGE | 9 |
| GENERAL INFORMATION..... | 9 |
| PREPARATION FOR STORAGE | 9 |
| REMOVING FROM STORAGE..... | 9 |
| LIMITED WARRANTY | 11 |
| PARTS | |
| 48" FLOATING PIN FORK CARRIAGE ASSEMBLY #11296 | 14-15 |
| 48" FLOATING PIN FORK CARRIAGE ASSEMBLY #11297 | 16-17 |
| 48" FLOATING PIN FORK CARRIAGE ASSEMBLY #11715 | 18-19 |
| 48" FLOATING PIN FORK CARRIAGE ASSEMBLY #12357 | 20-21 |
| 48" FLOATING PIN FORK CARRIAGE ASSEMBLY #12569 | 22-23 |
| 48" FLOATING PIN FORK CARRIAGE ASSEMBLY #12974..... | 24-25 |
| 48" FLOATING PIN FORK CARRIAGE ASSEMBLY #18354..... | 26-27 |

FOREWORD

Although The Major has various fork carriages available that are under 60", we are continually designing new sizes and mountings. If your combination is not listed, please contact the factory. We have extensive mounting information available to generate the product you need.

Below is a listing of the fork carriages that are currently available. See the "Parts" section of this manual for the assemblies "Shown".

| DESCRIPTION & MOUNT | ASSEMBLY # |
|---|-------------------|
| BLANK - NO MOUNT | |
| 48" Floating Pin Fork Carriage - NO MOUNT (Shown) | 12357 |
| CATERPILLAR | |
| 48" Floating Pin Fork Carriage - CAT IT/TH (Shown) | 11715 |
| 48" Floating Pin Fork Carriage - CAT 902/906/908 (Shown) | 12569 |
| GEHL | |
| 48" Floating Pin Fork Carriage - GEHL DYNACARRIER (Shown) | 11296 |
| 48" Floating Pin Fork Carriage - GEHL DYNATTACH (Shown) | 11297 |
| MANITOU | |
| 48" Floating Pin Fork Carriage - MANITOU (Shown) | 18354 |
| MEC | |
| 48" Floating Pin Fork Carriage - MEC (Shown) | 12974 |
| TEREX | |
| 48" Floating Pin Fork Carriage - TEREX TH (Shown) | 12974 |
| TRAK | |
| 48" Floating Pin Fork Carriage - TRAK (Shown) | 12974 |

NOTE: 48" CARRIAGE ASSEMBLY #12357 DOES NOT INCLUDE MOUNTING BRACKETS. CUSTOMER NEEDS TO WELD ON REQUIRED MOUNTS.

PREFACE

GENERAL COMMENTS

Congratulations on the purchase of your new attachment! This product was carefully designed and manufactured to give you many years of dependable service. Only minor maintenance, such as cleaning and lubricating, is required to keep it in top working condition. Be sure to observe all maintenance procedures and safety precautions in this manual and on any safety decals located on the product, and on any equipment on which the attachment is mounted. Also, check load charts before operating the attachment.

This manual has been designed to help you do a better, safer job. Read this manual carefully and become familiar with its contents.

WARNING! Never let anyone operate this unit without reading the “Safety Precautions” and “Operating Instructions” sections of this manual.



Always choose hard, level ground to park the vehicle on, and set the brake so the unit cannot roll.

Unless noted otherwise, right and left sides are determined from the operator’s control position when facing the attachment.

NOTE: The illustrations and data used in this manual were current, according to the information available to us at the time of printing. However, we reserve the right to redesign and change the attachment as may be necessary, without notification.

BEFORE OPERATION

The primary responsibility for safety with this equipment falls to the operator. Make sure the equipment is operated only by trained individuals who have read and understand this manual. If there is any portion of this manual or function that you do not understand, contact your local authorized dealer or the manufacturer.

SAFETY ALERT SYMBOL



This is the “Safety Alert Symbol” used by this industry. This symbol is used to warn of possible injury. Be sure to read all warnings carefully. They are included for your safety and for the safety of others working with you.

SERVICE

When servicing your product, remember to use only manufacturer replacement parts. Substitute parts may not meet the standards required for safe, dependable operation.

To facilitate parts ordering, record the model and serial number of your unit in the space provided on the cover of this manual. This information may be obtained from the identification plate located on the product.

The parts department needs this information to ensure that you receive the correct parts for your specific model.

SAFETY STATEMENTS



THIS SYMBOL BY ITSELF OR WITH A WARNING WORD THROUGHOUT THIS MANUAL IS USED TO CALL YOUR ATTENTION TO INSTRUCTIONS INVOLVING YOUR PERSONAL SAFETY OR THE SAFETY OF OTHERS. FAILURE TO FOLLOW THESE INSTRUCTIONS CAN RESULT IN INJURY OR DEATH.



DANGER

THIS SIGNAL WORD IS USED WHERE SERIOUS INJURY OR DEATH WILL RESULT IF THE INSTRUCTIONS ARE NOT FOLLOWED PROPERLY.



WARNING

THIS SIGNAL WORD IS USED WHERE SERIOUS INJURY OR DEATH COULD RESULT IF THE INSTRUCTIONS ARE NOT FOLLOWED PROPERLY.



CAUTION

THIS SIGNAL WORD IS USED WHERE MINOR INJURY COULD RESULT IF THE INSTRUCTIONS ARE NOT FOLLOWED PROPERLY.

NOTICE

NOTICE INDICATES A PROPERTY DAMAGE MESSAGE.

GENERAL SAFETY PRECAUTIONS

WARNING!

READ MANUAL PRIOR TO INSTALLATION



Improper installation, operation, or maintenance of this equipment could result in serious injury or death. Operators and maintenance personnel should read this manual, as well as all manuals related to this equipment and the prime mover thoroughly before beginning installation, operation, or maintenance. **FOLLOW ALL SAFETY INSTRUCTIONS IN THIS MANUAL AND THE PRIME MOVER'S MANUAL(S).**



READ AND UNDERSTAND ALL SAFETY STATEMENTS

Read all safety decals and safety statements in all manuals prior to operating or working on this equipment. Know and obey all OSHA regulations, local laws, and other professional guidelines for your operation. Know and follow good work practices when assembling, maintaining, repairing, mounting, removing, or operating this equipment.



KNOW YOUR EQUIPMENT

Know your equipment's capabilities, dimensions, and operations before operating. Visually inspect your equipment before you start, and never operate equipment that is not in proper working order with all safety devices intact. Check all hardware to ensure it is tight. Make certain that all locking pins, latches, and connection devices are properly installed and secured. Remove and replace any damaged, fatigued, or excessively worn parts. Make certain all safety decals are in place and are legible. Keep decals clean, and replace them if they become worn or hard to read.

GENERAL SAFETY PRECAUTIONS

WARNING!



PROTECT AGAINST FLYING DEBRIS

Always wear proper safety glasses, goggles, or a face shield when driving pins in or out, or when any operation causes dust, flying debris, or any other hazardous material.

WARNING!



LOWER OR SUPPORT RAISED EQUIPMENT

Do not work under raised booms without supporting them. Do not use support material made of concrete blocks, logs, buckets, barrels, or any other material that could suddenly collapse or shift positions. Make sure support material is solid, not decayed, warped, twisted, or tapered. Lower booms to ground level or on blocks. Lower booms and attachments to the ground before leaving the cab or operator's station.

WARNING!



USE CARE WITH HYDRAULIC FLUID PRESSURE

Hydraulic fluid under pressure can penetrate the skin and cause serious injury or death. Hydraulic leaks under pressure may not be visible. Before connecting or disconnecting hydraulic hoses, read your prime mover's operator's manual for detailed instructions on connecting and disconnecting hydraulic hoses or fittings.

- Keep unprotected body parts, such as face, eyes, and arms as far away as possible from a suspected leak. Flesh injected with hydraulic fluid may develop gangrene or other permanent disabilities.
- If injured by injected fluid, see a doctor at once. If your doctor is not familiar with this type of injury, ask him to research it immediately to determine proper treatment.
- Wear safety glasses, protective clothing, and use a piece of cardboard or wood when searching for hydraulic leaks. **DO NOT USE YOUR HANDS! SEE ILLUSTRATION.**

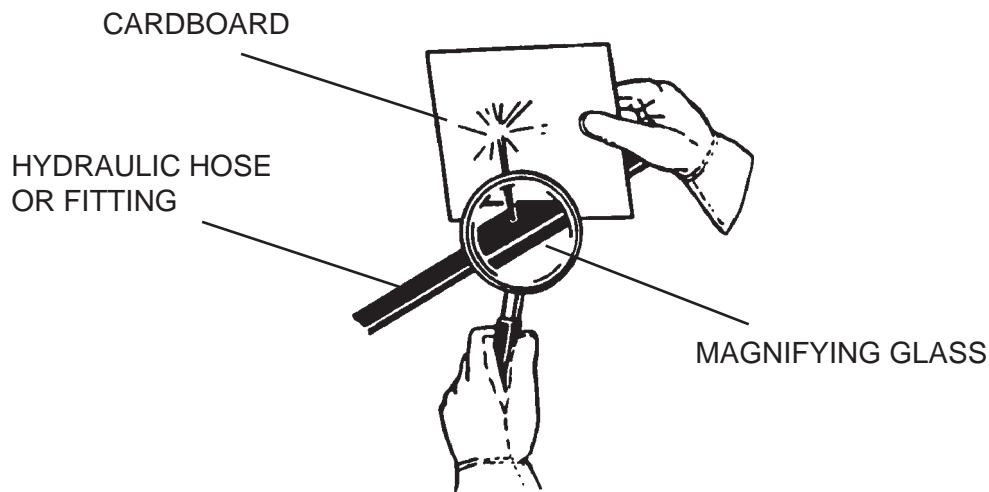

M-807 7-28-05-2

GENERAL SAFETY PRECAUTIONS

WARNING!



DO NOT MODIFY MACHINE OR ATTACHMENTS

Modifications may weaken the integrity of the attachment and may impair the function, safety, life, and performance of the attachment. When making repairs, use only the manufacturer's genuine parts, following authorized instructions. Other parts may be substandard in fit and quality. Never modify any ROPS (Roll Over Protection Structure) or FOPS (Falling Object Protective Structure) equipment or device. Any modifications must be authorized in writing by the manufacturer.

WARNING!



SAFELY MAINTAIN AND REPAIR EQUIPMENT

- Do not wear loose clothing or any accessories that can catch in moving parts. If you have long hair, cover or secure it so that it does not become entangled in the equipment.
- Work on a level surface in a well-lit area.
- Use properly grounded electrical outlets and tools.
- Use the correct tools for the job at hand. Make sure they are in good condition for the task required.
- Wear the protective equipment specified by the tool manufacturer.



SAFELY OPERATE EQUIPMENT

Do not operate equipment until you are completely trained by a qualified operator in how to use the controls, know its capabilities, dimensions, and all safety requirements. See your machine's manual for these instructions.

- Keep all step plates, grab bars, pedals, and controls free of dirt, grease, debris, and oil.
- Never allow anyone to be around the equipment when it is operating.
- Do not allow riders on the attachment or the prime mover.
- Do not operate the equipment from anywhere other than the correct operator's position.
- Never leave equipment unattended with the engine running, or with this attachment in a raised position.
- Do not alter or remove any safety feature from the prime mover or this attachment.
- Know your work site safety rules as well as traffic rules and flow. When in doubt on any safety issue, contact your supervisor or safety coordinator for an explanation.

EQUIPMENT SAFETY PRECAUTIONS

WARNING!



KNOW WHERE UTILITIES ARE

Observe overhead electrical and other utility lines. Be sure equipment will clear them. When digging, call your local utilities for location of buried utility lines, gas, water, and sewer, as well as any other hazard you may encounter.



OPERATING THE PRIME MOVER

Avoid steep hillside operation, which could cause the prime mover to overturn. Consult your machine operator's and safety manuals for maximum incline allowable.

When operating on a slope, keep the load low, and proceed with extreme caution.

Do not drive ACROSS a steep slope - drive straight up and down.

With LOADED forks - drive with the forks and load facing uphill.

With EMPTY forks - drive with the forks facing downhill.



WORKING WITH THE ATTACHMENT

- Never use the attachment for a work platform or personnel carrier.
- Specified lift capacities must not be exceeded, otherwise machine stability will not be sufficient. Always observe lift capacity limits listed in machine specifications or on load charts furnished with the prime mover.
- An operator must not use drugs or alcohol, which can change his or her alertness or coordination. An operator taking prescription or over-the-counter drugs should seek medical advice on whether or not he or she can safely operate equipment.
- Always check locking pins before operating any attachment.
- Never lift, move, or swing loaded forks over anyone.
- Always space the forks correctly for the load. Loads can fall off incorrectly spaced forks. Make sure the forks are completely under the load before lifting.
- Never stack loads on uneven ground. Loads stacked on uneven ground can topple.
- Never lift a load with one fork. A load lifted with one fork can slip off and cause injury.
- Secure loads properly. Unsecured loads can fall unexpectedly.
- Do not handle round bales with fork lift tines.
- Don't obstruct your vision when traveling or working. Carry the forks low for maximum stability and visibility.



MAINTAINING THE ATTACHMENT

- Never perform any work on the equipment unless you are authorized and qualified to do so. Always read the operator's and service manual(s) before any repair is made. After completing maintenance or repair, check for correct functioning of the attachment. If not functioning properly, always attach a "DO NOT OPERATE" tag to the machine until all problems are corrected.
- Worn, damaged, or illegible safety decals must be replaced. New safety decals can be ordered from the manufacturer.

INSTALLATION AND OPERATION

ATTACHING AND DETACHING EQUIPMENT

Please see your vehicle operator's manual for instructions on attaching and detaching your equipment.

WARNING!



To prevent serious personal injury or death, only attach equipment that is designed for your prime mover.

Specified lift capacities must not be exceeded, otherwise machine stability will not be sufficient. Always observe lift capacity limits listed in machine specifications.

NOTE: THE 48" CARRIAGE ASSEMBLY #12357 DOES NOT INCLUDE MOUNTING BRACKETS. YOU WILL NEED TO WELD ON YOUR REQUIRED MOUNTS FOR THIS ASSEMBLY.

OPERATING EQUIPMENT

Read all Safety Precautions before operating your new attachment.

For personal safety, lower the attachment to the ground, set the parking brake, shut off engine, and remove key before getting off of your prime mover.

STORAGE

GENERAL INFORMATION

The following storage procedure will help you to keep your attachment in top condition. It will also help you get off to a good start the next time your equipment is needed. We therefore strongly recommend that you take the extra time to follow these procedures whenever your attachment will not be used for an extended period of time.

PREPARATION FOR STORAGE

1. Clean the attachment thoroughly, removing all mud, dirt, and grease.
2. Inspect for visible signs of wear, breakage, or damage. Order any parts required, and make the necessary repairs, to avoid delays when starting next season.
3. Tighten all loose nuts and capscrews.
4. Touch up all unpainted and exposed areas with paint, to prevent rust.
5. Replace decals, if damaged or in unreadable condition.
6. Store the attachment in a dry and protected place, with a cover, if possible. Leaving the attachment outside will materially shorten its life.

REMOVING FROM STORAGE

1. Remove all protective coverings.

LIMITED WARRANTY

All new Major products are warranted to be free from defects in materials or workmanship which may cause failure under normal usage and service, when used for the purpose intended.

In the event of failure within twelve (12) months from initial retail sale, lease or rental date (excluding cable, ground engaging parts such as sprockets, digging chain, bearings, teeth, tamping and demolition heads, blade cutting edges, pilot bits, auger teeth, auger heads & broom bristles), if after examination, The Major determines failure was due to defective material and/or workmanship, parts will be repaired or replaced. The Major may request defective part or parts be returned prepaid to them for inspection at their place of business at Delhi, Iowa, or to a location specified by The Major.

Any claims under this warranty must be made within fifteen (15) days after the Buyer learns of the facts upon which such claim is based. All claims not made in writing and received by The Major within the time period specified above shall be deemed waived.

THIS WARRANTY IS IN LIEU OF ALL OTHER WARRANTIES EXPRESSED OR IMPLIED, AND THERE ARE NO WARRANTIES OF MERCHANTABILITY OR OF FITNESS FOR A PARTICULAR PURPOSE. IN NO EVENT SHALL THE MAJOR BE LIABLE FOR CONSEQUENTIAL OR SPECIAL DAMAGE.

THE MAJOR'S LIABILITY FOR ANY AND ALL LOSSES AND DAMAGES TO BUYER, RESULTING FROM ANY CAUSE WHATSOEVER, INCLUDING THE MAJOR'S NEGLIGENCE, IRRESPECTIVE OF WHETHER SUCH DEFECTS ARE DISCOVERABLE OR LATENT, SHALL IN NO EVENT EXCEED THE PURCHASE PRICE OF THE PARTICULAR PRODUCTS WITH RESPECT TO WHICH LOSSES OR DAMAGES ARE CLAIMED, OR, AT THE ELECTION OF THE MAJOR, THE REPAIR OR REPLACEMENT OF DEFECTIVE OR DAMAGED PRODUCTS.

PARTS

The following section contains detailed diagrams and parts lists which include your attachment. Please use these diagrams and parts lists to locate replacement parts, prior to contacting the parts department.

When servicing your attachment, remember to use only original manufacturer replacement parts. Substitute parts may not meet the standards required for safe, dependable operation.

To facilitate parts ordering, have the model and serial number of your product ready, to ensure that you receive the correct parts for your specific attachment.

The model and serial number for your attachment should be recorded in the space provided on the cover of this manual. This information may be obtained from the serial number identification plate located on your attachment. **See the parts diagram for your attachment for the location.**

NOTE: Most daily and emergency orders received by 2:00 P.M. will be shipped the same day received, with “Emergency-Machine-Down” orders receiving first priority.



PARTS DEPARTMENT

(563) 922-2981

(800) 922-2981

We Encourage Fax Orders

(563) 922-2593

M-1127 10-4-06-2

FORK CARRIAGE - FLOATING PIN

48" WIDE - ASSEMBLY #11296

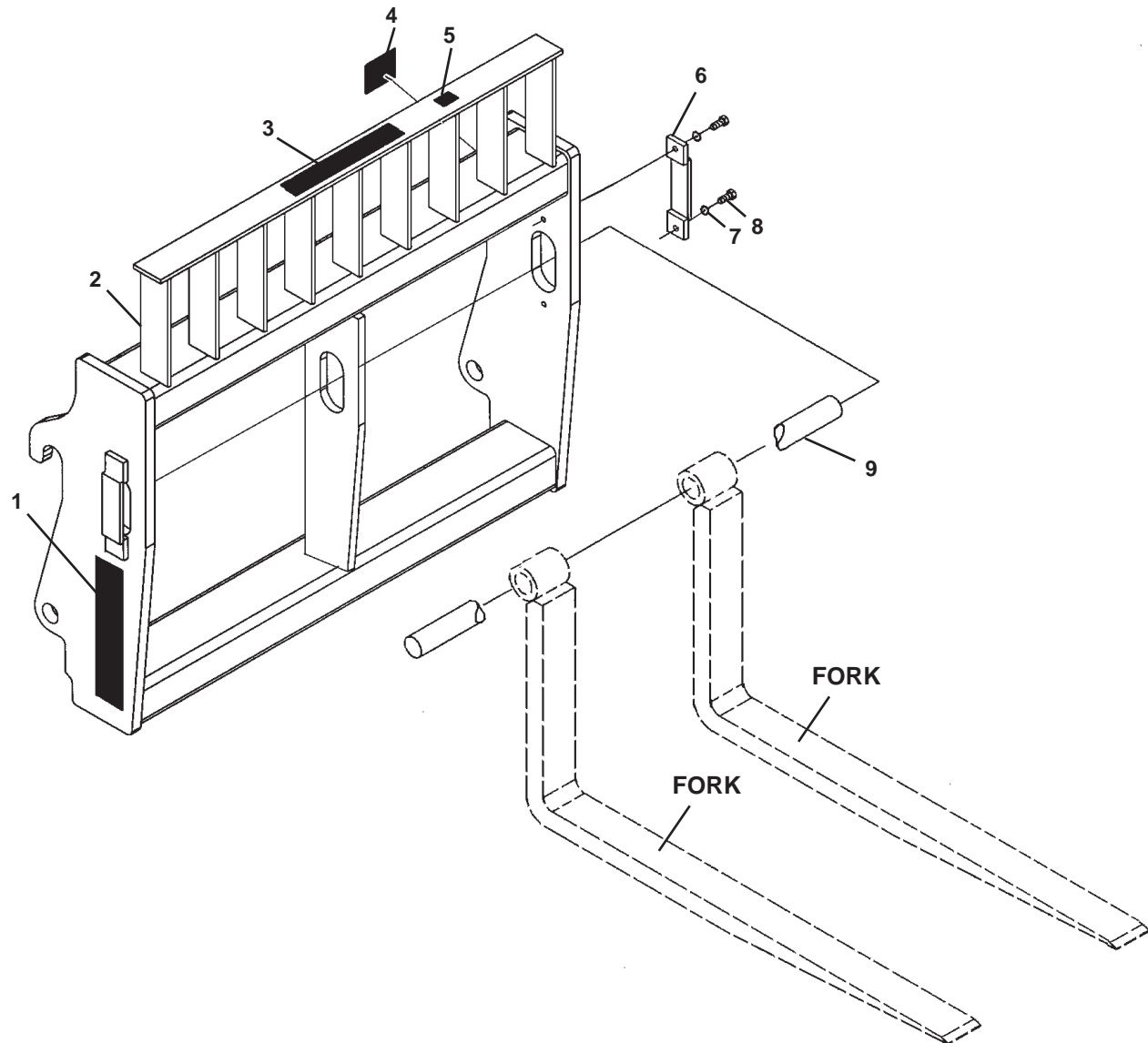
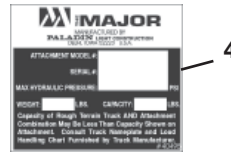

FORK CARRIAGE - FLOATING PIN

48" WIDE - ASSEMBLY #11296

| <u>ITEM</u> | <u>QTY.</u> | <u>PART NO.</u> | <u>DESCRIPTION</u> |
|-------------|-------------|-----------------|---|
| 1 | 2 | 40501 | Major Logo, Small |
| 2 | 1 | 18230 | 48" Fork Carriage |
| 3 | 1 | 40502 | Major Logo, Medium |
| 4 | 1 | ----- | Serial Number Identification Tag Location |
| 5 | 1 | 4338 | Made in the USA Decal |
| 6 | 1 | 14002 | Fork Pin Retainer |
| 7 | 2 | 1505 | .50" Lock Washer |
| 8 | 2 | 1338 | .50" UNF x 1.00" Hex Capscrew |
| 9 | 1 | 16448 | Fork Pin, 2.50" x 48.50" |

***CONTACT YOUR DEALER FOR TINES AVAILABLE FOR YOUR ATTACHMENT.**

M-1315 10-12-06

FORK CARRIAGE - FLOATING PIN

48" WIDE - ASSEMBLY #11297

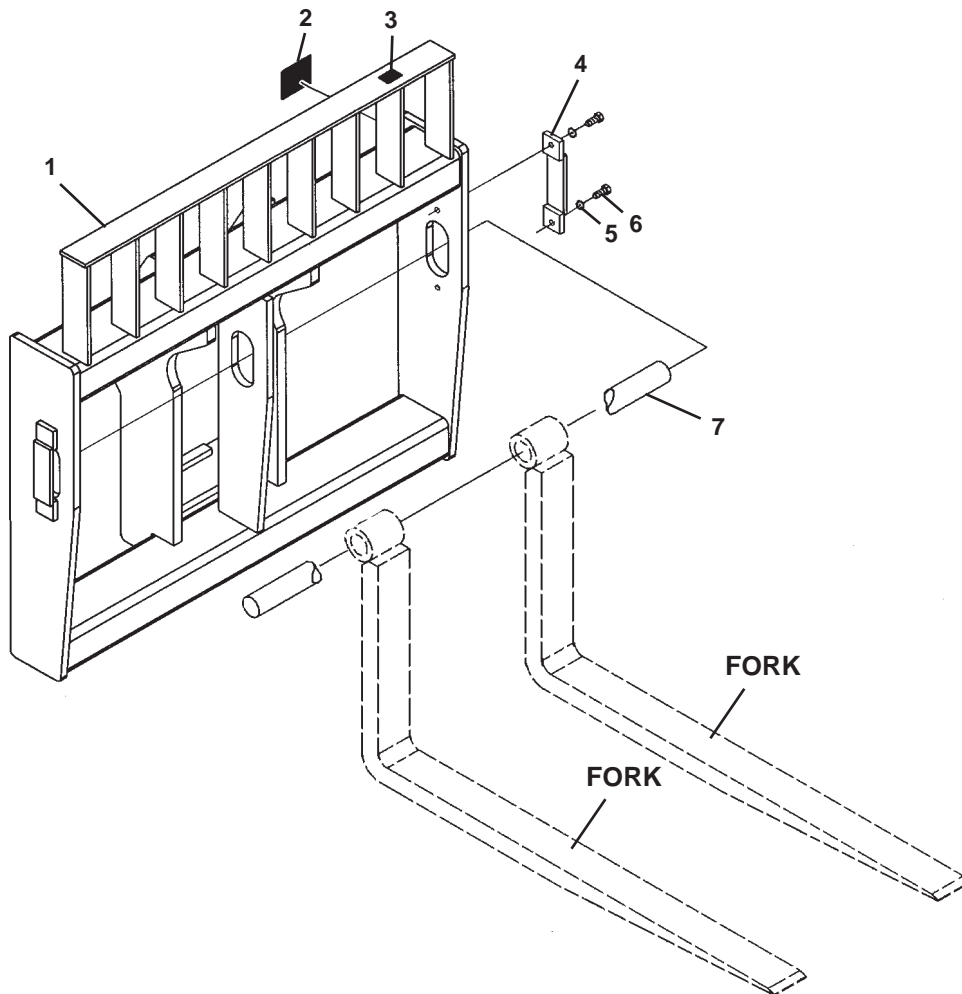
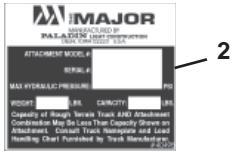

FORK CARRIAGE - FLOATING PIN

48" WIDE - ASSEMBLY #11297

| <u>ITEM</u> | <u>QTY.</u> | <u>PART NO.</u> | <u>DESCRIPTION</u> |
|-------------|-------------|-----------------|---|
| 1 | 1 | 16447 | 48" Fork Carriage |
| 2 | 1 | ----- | Serial Number Identification Tag Location |
| 3 | 1 | 4338 | Made in the USA Decal |
| 4 | 1 | 14002 | Fork Pin Retainer |
| 5 | 2 | 1505 | .50" Lock Washer |
| 6 | 2 | 1338 | .50" UNF x 1.00" Hex Capscrew |
| 7 | 1 | 16448 | Fork Pin, 2.50" x 48.50" |

***CONTACT YOUR DEALER FOR TINES AVAILABLE FOR YOUR ATTACHMENT.**

M-1309 10-12-06

FORK CARRIAGE - FLOATING PIN

48" WIDE - ASSEMBLY #11715

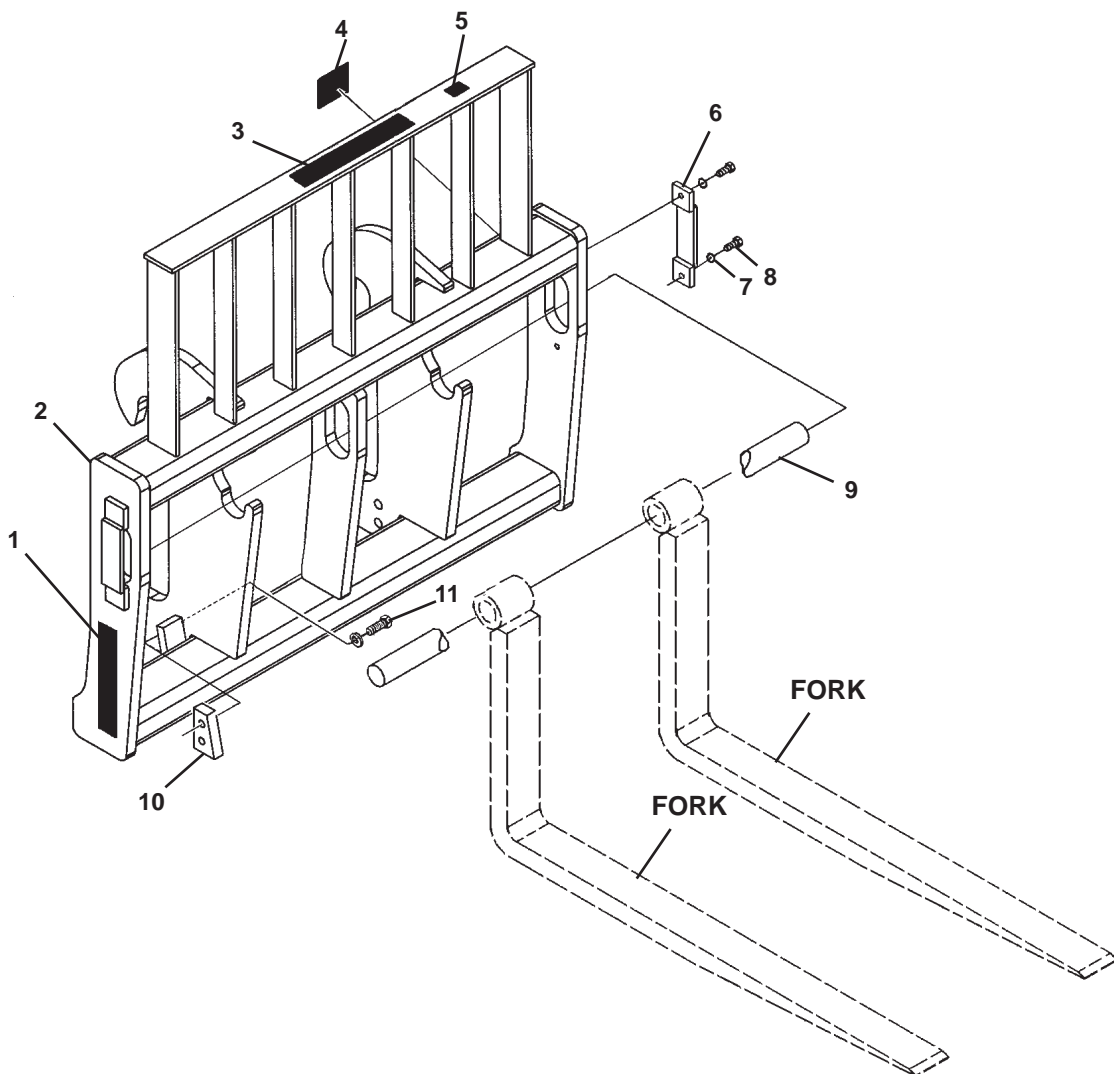
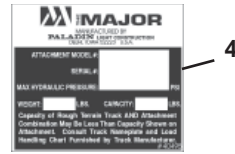

FORK CARRIAGE - FLOATING PIN

48" WIDE - ASSEMBLY #11715

| <u>ITEM</u> | <u>QTY.</u> | <u>PART NO.</u> | <u>DESCRIPTION</u> |
|-------------|-------------|-----------------|---|
| 1 | 2 | 40501 | Major Logo, Small |
| 2 | 1 | 15247 | 48" Fork Carriage |
| 3 | 1 | 40502 | Major Logo, Medium |
| 4 | 1 | ----- | Serial Number Identification Tag Location |
| 5 | 1 | 4338 | Made in the USA Decal |
| 6 | 1 | 14002 | Fork Pin Retainer |
| 7 | 2 | 1505 | .50" Lock Washer |
| 8 | 2 | 1338 | .50" UNF x 1.00" Hex Capscrew |
| 9 | 1 | 14262 | Fork Pin, 60mm x 48.50" |
| 10 | 2 | 14228 | Stop Block |
| 11 | 2 | 10012 | .75" UNC x 2.25" Hex Capscrew, Grade 8 |
| | 2 | 1507 | .75" Lock Washer |

***CONTACT YOUR DEALER FOR TINES AVAILABLE FOR YOUR ATTACHMENT.**

M-1313 11-14-06

FORK CARRIAGE - FLOATING PIN

48" WIDE - ASSEMBLY #12357

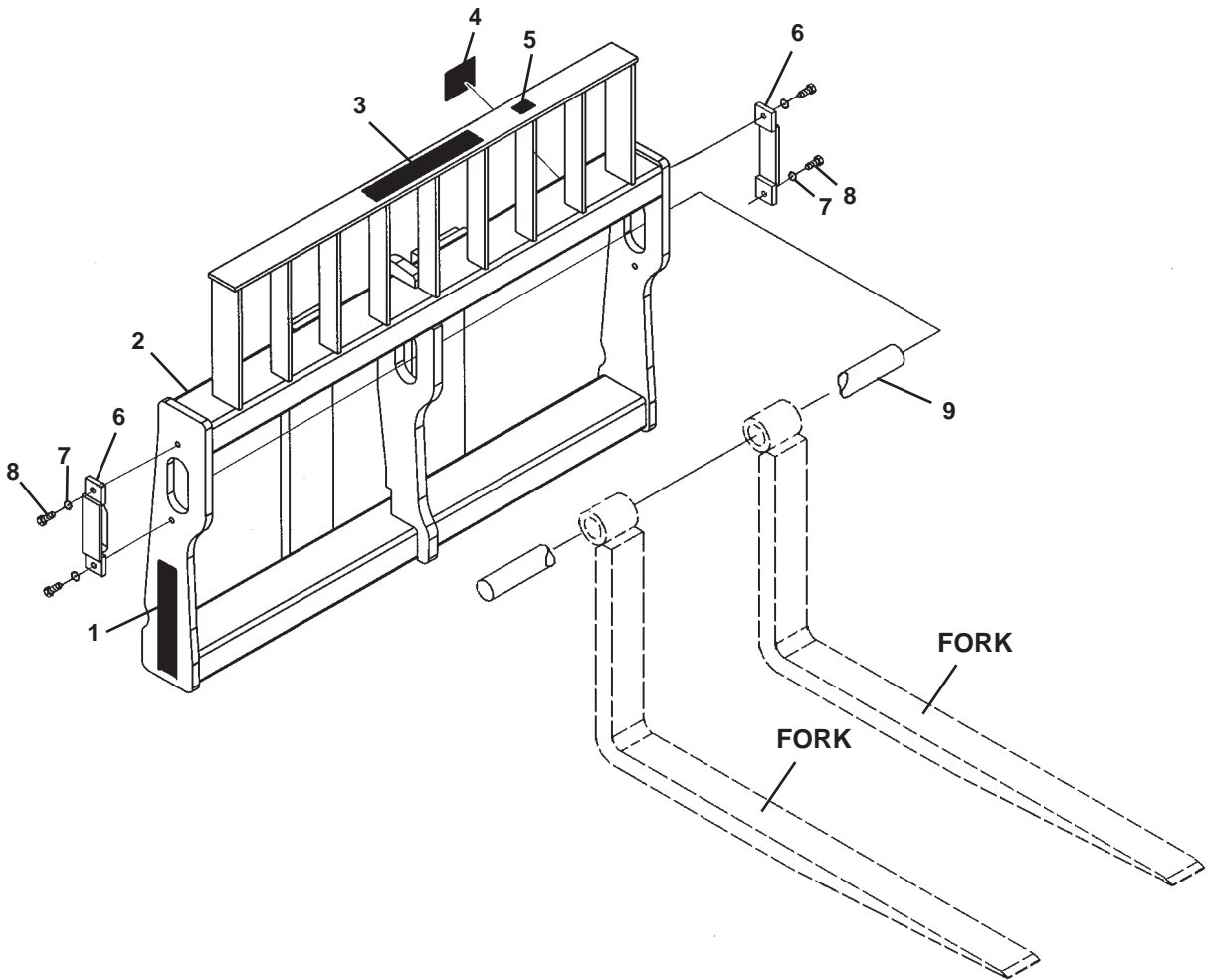
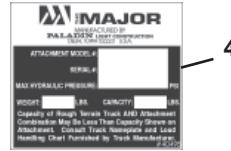

FORK CARRIAGE - FLOATING PIN

48" WIDE - ASSEMBLY #12357

| <u>ITEM</u> | <u>QTY.</u> | <u>PART NO.</u> | <u>DESCRIPTION</u> |
|-------------|-------------|-----------------|---|
| 1 | 2 | 40501 | Major Logo, Small |
| 2 | 1 | 15381 | 48" Fork Carriage Frame - No Mounts |
| 3 | 1 | 40502 | Major Logo, Medium |
| 4 | 1 | ----- | Serial Number Identification Tag Location |
| 5 | 1 | 4338 | Made in the USA Decal |
| 6 | 2 | 14002 | Fork Pin Retainer |
| 7 | 4 | 1505 | .50" Lock Washer |
| 8 | 4 | 1339 | .50" UNF x 1.25" Hex Capscrew |
| 9 | 1 | 32609 | Fork Pin, 2.25" x 53.43" |

NOTE: 48" CARRIAGE ASSEMBLY #12357 DOES NOT INCLUDE MOUNTING BRACKETS. CUSTOMER NEEDS TO WELD ON REQUIRED MOUNTS.

***CONTACT YOUR DEALER FOR TINES AVAILABLE FOR YOUR ATTACHMENT.**

M-1317 11-14-06

FORK CARRIAGE - FLOATING PIN

48" WIDE - ASSEMBLY #12569

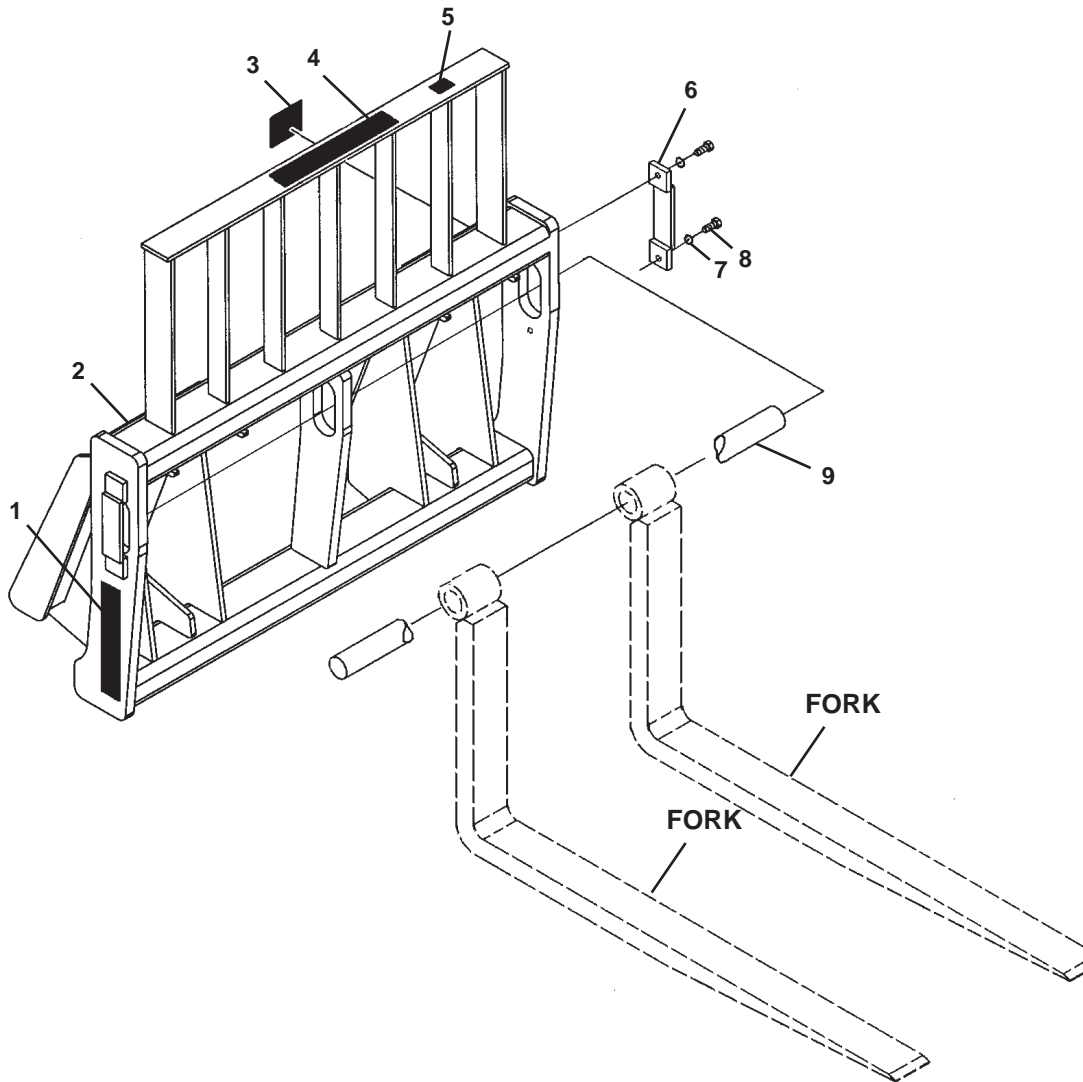
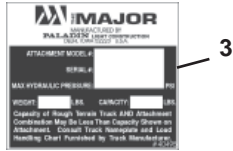

FORK CARRIAGE - FLOATING PIN

48" WIDE - ASSEMBLY #12569

| <u>ITEM</u> | <u>QTY.</u> | <u>PART NO.</u> | <u>DESCRIPTION</u> |
|-------------|-------------|-----------------|---|
| 1 | 2 | 40501 | Major Logo, Small |
| 2 | 1 | 19133 | 48" Fork Carriage |
| 3 | 1 | ----- | Serial Number Identification Tag Location |
| 4 | 1 | 40502 | Major Logo, Medium |
| 5 | 1 | 4338 | Made in the USA Decal |
| 6 | 1 | 14002 | Fork Pin Retainer |
| 7 | 2 | 1505 | .50" Lock Washer |
| 8 | 2 | 1338 | .50" UNF x 1.00" Hex Capscrew |
| 9 | 1 | 14262 | Fork Pin, 60mm x 48.50" |

***CONTACT YOUR DEALER FOR TINES AVAILABLE FOR YOUR ATTACHMENT.**

M-1311 11-14-06

FORK CARRIAGE - FLOATING PIN

48" WIDE - ASSEMBLY #12974

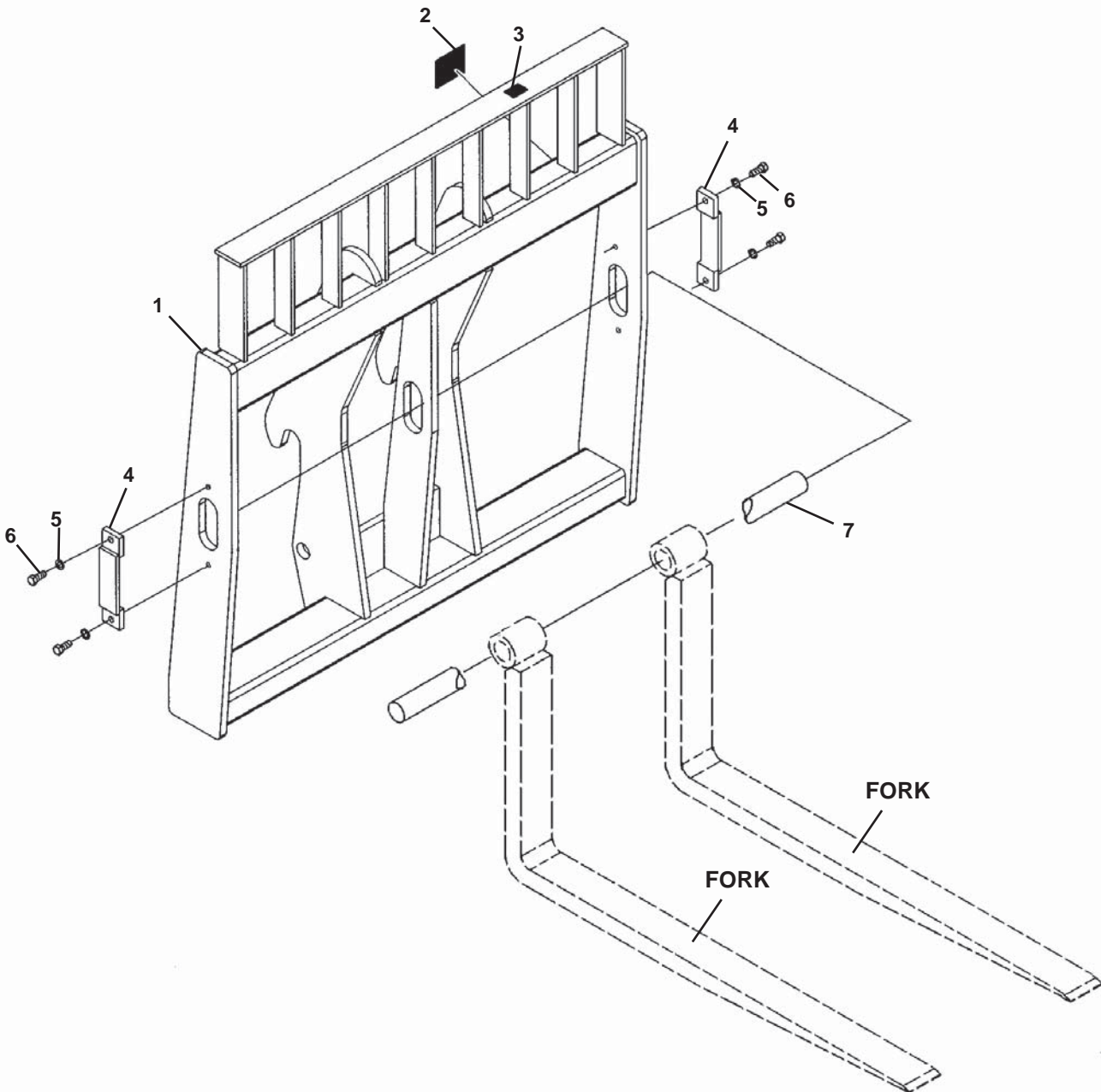

M-1361 11-14-06

FORK CARRIAGE - FLOATING PIN

48" WIDE - ASSEMBLY #12974

| <u>ITEM</u> | <u>QTY.</u> | <u>PART NO.</u> | <u>DESCRIPTION</u> |
|-------------|-------------|-----------------|---|
| 1 | 1 | 19060 | 48" Fork Carriage |
| 2 | 1 | ----- | Serial Number Identification Tag Location |
| 3 | 1 | 4338 | Made in the USA Decal |
| 4 | 2 | 14002 | Fork Pin Retainer |
| 5 | 4 | 1505 | .50" Lock Washer |
| 6 | 4 | 1339 | .50" UNF x 1.25" Hex Capscrew |
| 7 | 1 | 14338 | Fork Pin, 2.00" x 50.25" |

***CONTACT YOUR DEALER FOR TINES AVAILABLE FOR YOUR ATTACHMENT.**

M-1362 10-12-06

FORK CARRIAGE - FLOATING PIN

48" WIDE - ASSEMBLY #18354

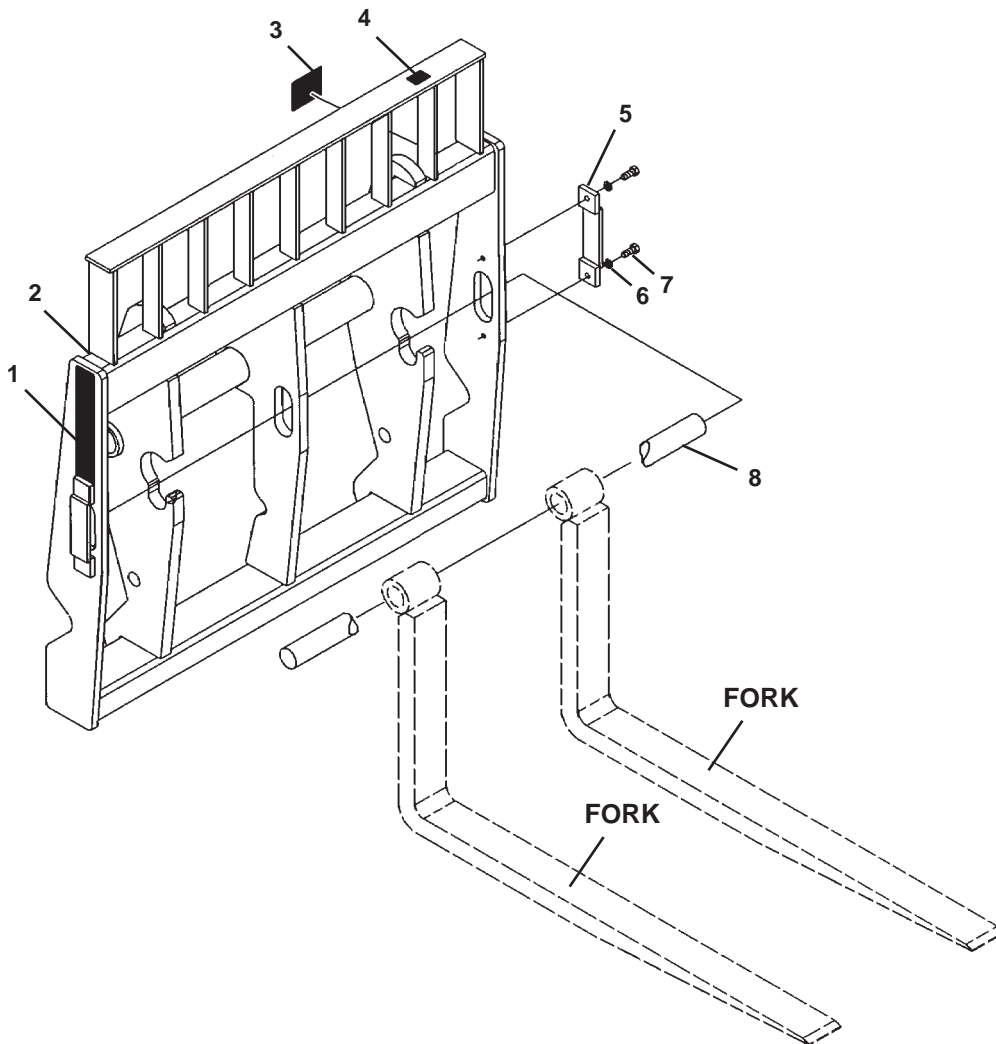
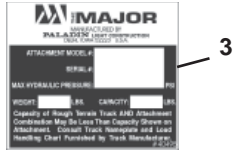

FORK CARRIAGE - FLOATING PIN

48" WIDE - ASSEMBLY #18354

| <u>ITEM</u> | <u>QTY.</u> | <u>PART NO.</u> | <u>DESCRIPTION</u> |
|-------------|-------------|-----------------|---|
| 1 | 2 | 40501 | Major Logo, Small |
| 2 | 1 | 18355 | 48" Fork Carriage |
| 3 | 1 | ----- | Serial Number Identification Tag Location |
| 4 | 1 | 4338 | Made in the USA Decal |
| 5 | 1 | 14002 | Fork Pin Retainer |
| 6 | 2 | 1505 | .50" Lock Washer |
| 7 | 2 | 1339 | .50" UNF x 1.25" Hex Capscrew |
| 8 | 1 | 14338 | Fork Pin, 2.00" x 50.25" |

***CONTACT YOUR DEALER FOR TINES AVAILABLE FOR YOUR ATTACHMENT.**

M-1080 10-14-05



**P.O. Box 266
Delhi, IA 52223-0266**

**(563) 922-2981
(800) 922-2981**

www.paladinbrands.com

M-1360 10-4-06