



OPERATOR'S & PARTS MANUAL

48" - 74" SIDE SHIFT FORK CARRIAGE



PALADIN LIGHT CONSTRUCTION

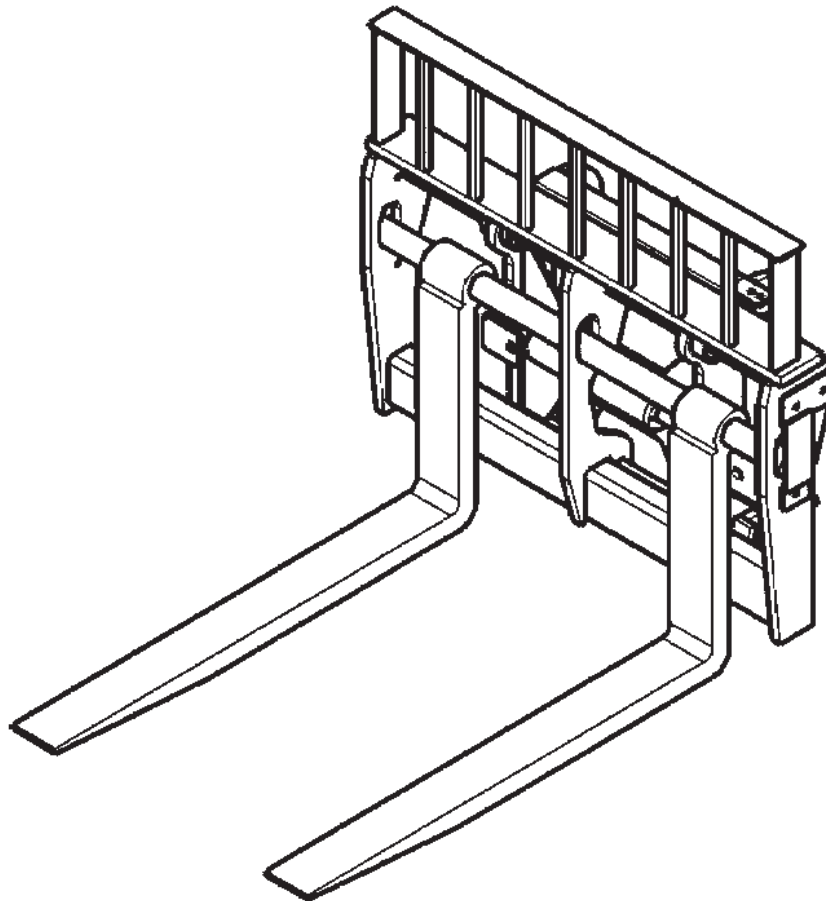

SERIAL NUMBER: _____

MODEL NUMBER: _____

Manual Number: 76826

Part Number: 76826

Date: 7-30-08

TABLE OF CONTENTS

FOREWORD	2
PREFACE	3
SAFETY PRECAUTIONS	4-8
SAFETY STATEMENTS	4
GENERAL SAFETY PRECAUTIONS.....	4-6
EQUIPMENT SAFETY PRECAUTIONS	7-8
INSTALLATION AND OPERATION	9-12
ATTACHING AND DETACHING SIDE SHIFT FORK CARRIAGE	9
OPERATING SIDE SHIFT FORK CARRIAGE	9-10
TROUBLESHOOTING	11
MAINTENANCE AND SERVICE	13-15
GENERAL INFORMATION.....	13
DAILY	13
EVERY 40 HOURS	13
CYLINDER SEAL REPLACEMENT	14-15
SPECIFICATIONS	16
BOLT TORQUE	17
STORAGE	18
LIMITED WARRANTY	19
PARTS	
<u>SIDE SHIFT FORK CARRIAGES</u>	
48" SIDE SHIFT FORK CARRIAGE ASSEMBLY #11324	22-23
48" SIDE SHIFT FORK CARRIAGE ASSEMBLY #12426	24-25
48" SIDE SHIFT FORK CARRIAGE ASSEMBLY #12633	26-27
48" SIDE SHIFT FORK CARRIAGE ASSEMBLY #12540	28-29
48" SIDE SHIFT FORK CARRIAGE ASSEMBLY #12644	30-31
48" SIDE SHIFT FORK CARRIAGE ASSEMBLY #12659	32-33
48" SIDE SHIFT FORK CARRIAGE ASSEMBLY #12966	34-35
60" SIDE SHIFT FORK CARRIAGE ASSEMBLY #12703	36-37
66" SIDE SHIFT FORK CARRIAGE ASSEMBLY #12319	38-39
74" SIDE SHIFT FORK CARRIAGE ASSEMBLY #11510	40-41
74" SIDE SHIFT FORK CARRIAGE ASSEMBLY #12965	42-43
<u>CYLINDERS</u>	
CYLINDER ASSEMBLY #88920	44-45
CYLINDER ASSEMBLY #88928	46-47

FOREWORD

Although The Major has various side shift fork carriages available, we are continually designing new sizes and mountings. If your combination is not listed, please contact the factory. We have extensive mounting information available to generate the product you need.

Below is a listing of the side shift fork carriages that are currently available. See the "Parts" section of this manual for the assemblies "Shown".

<i>DESCRIPTION & MOUNT</i>	<i>ASSEMBLY #</i>
CATERPILLAR	
48" Side Shift Fork Carriage - CAT IT/TH 10,000 LB CAP 60MM SHAFT (Shown)	11324
74" Side Shift Fork Carriage - CAT IT/TH 10,000 LB CAP 60MM SHAFT (Shown)	11510
GEHL	
66" Side Shift Fork Carriage - GEHL DYNACARRIER (Shown)	12319
IR	
48" Side Shift Fork Carriage - IR VR518/VR623 6,000 LB CAP 2" SHAFT (Shown)	12426
JCB	
48" Side Shift Fork Carriage - JCB 10,000 LB CAP 2 1/4 SHAFT (Shown)	12633
48" Side Shift Fork Carriage - JCB 520 5,500 LB CAP ITA CLASS II (Shown)	12644
48" Side Shift Fork Carriage - JCB 10,000 LB CAP, ITA CLASS III (Shown)	12659
JLG	
48" Side Shift Fork Carriage - JLG/GRADALL "C" SERIES (Shown)	12966
74" Side Shift Fork Carriage - JLG/GRADALL "C" SERIES (Shown)	12965
MANITOU	
60" Side Shift Fork Carriage - MANITOU 10,000 LB CAP, ITA CLASS III (Shown)	12703
NEW HOLLAND	
48" Side Shift Fork Carriage - NH 10,000 LB CAP 2 1/4 SHAFT (Shown)	12633
48" Side Shift Fork Carriage - NH VERSATTACH 10,000 LB CAP, ITA CLASS II (Shown)	12659
TEREX	
48" Side Shift Fork Carriage - TEREX TX51-19 TEREX HITCH (Shown)	12540

PREFACE

GENERAL COMMENTS

Congratulations on the purchase of your new attachment! This product was carefully designed and manufactured to give you many years of dependable service. Only minor maintenance, such as cleaning and lubricating, is required to keep it in top working condition. Be sure to observe all maintenance procedures and safety precautions in this manual and on any safety decals located on the product, and on any equipment on which the attachment is mounted. Also, check load charts before operating the attachment.

This manual has been designed to help you do a better, safer job. Read this manual carefully and become familiar with its contents.

WARNING! Never let anyone operate this unit without reading the “Safety Precautions” and “Operating Instructions” sections of this manual.



Always choose hard, level ground to park the vehicle on, and set the brake so the unit cannot roll.

Unless noted otherwise, right and left sides are determined from the operator’s control position when facing the attachment.

NOTE: The illustrations and data used in this manual were current, according to the information available to us at the time of printing. However, we reserve the right to redesign and change the attachment as may be necessary, without notification.

BEFORE OPERATION

The primary responsibility for safety with this equipment falls to the operator. Make sure the equipment is operated only by trained individuals who have read and understand this manual. If there is any portion of this manual or function that you do not understand, contact your local authorized dealer or the manufacturer.

SAFETY ALERT SYMBOL



This is the “Safety Alert Symbol” used by this industry. This symbol is used to warn of possible injury. Be sure to read all warnings carefully. They are included for your safety and for the safety of others working with you.

SERVICE

When servicing your product, remember to use only manufacturer replacement parts. Substitute parts may not meet the standards required for safe, dependable operation.

To facilitate parts ordering, record the model and serial number of your unit in the space provided on the cover of this manual. This information may be obtained from the identification plate located on the product.

The parts department needs this information to ensure that you receive the correct parts for your specific model.

SAFETY STATEMENTS



THIS SYMBOL BY ITSELF OR WITH A WARNING WORD THROUGHOUT THIS MANUAL IS USED TO CALL YOUR ATTENTION TO INSTRUCTIONS INVOLVING YOUR PERSONAL SAFETY OR THE SAFETY OF OTHERS. FAILURE TO FOLLOW THESE INSTRUCTIONS CAN RESULT IN INJURY OR DEATH.



DANGER

THIS SIGNAL WORD IS USED WHERE SERIOUS INJURY OR DEATH WILL RESULT IF THE INSTRUCTIONS ARE NOT FOLLOWED PROPERLY.



WARNING

THIS SIGNAL WORD IS USED WHERE SERIOUS INJURY OR DEATH COULD RESULT IF THE INSTRUCTIONS ARE NOT FOLLOWED PROPERLY.



CAUTION

THIS SIGNAL WORD IS USED WHERE MINOR INJURY COULD RESULT IF THE INSTRUCTIONS ARE NOT FOLLOWED PROPERLY.

NOTICE

NOTICE INDICATES A PROPERTY DAMAGE MESSAGE.

GENERAL SAFETY PRECAUTIONS

WARNING!

READ MANUAL PRIOR TO INSTALLATION



Improper installation, operation, or maintenance of this equipment could result in serious injury or death. Operators and maintenance personnel should read this manual, as well as all manuals related to this equipment and the prime mover thoroughly before beginning installation, operation, or maintenance. **FOLLOW ALL SAFETY INSTRUCTIONS IN THIS MANUAL AND THE PRIME MOVER'S MANUAL(S).**



READ AND UNDERSTAND ALL SAFETY STATEMENTS

Read all safety decals and safety statements in all manuals prior to operating or working on this equipment. Know and obey all OSHA regulations, local laws, and other professional guidelines for your operation. Know and follow good work practices when assembling, maintaining, repairing, mounting, removing, or operating this equipment.



KNOW YOUR EQUIPMENT

Know your equipment's capabilities, dimensions, and operations before operating. Visually inspect your equipment before you start, and never operate equipment that is not in proper working order with all safety devices intact. Check all hardware to ensure it is tight. Make certain that all locking pins, latches, and connection devices are properly installed and secured. Remove and replace any damaged, fatigued, or excessively worn parts. Make certain all safety decals are in place and are legible. Keep decals clean, and replace them if they become worn or hard to read.

GENERAL SAFETY PRECAUTIONS

WARNING!



PROTECT AGAINST FLYING DEBRIS

Always wear proper safety glasses, goggles, or a face shield when driving pins in or out, or when any operation causes dust, flying debris, or any other hazardous material.

WARNING!



LOWER OR SUPPORT RAISED EQUIPMENT

Do not work under raised booms without supporting them. Do not use support material made of concrete blocks, logs, buckets, barrels, or any other material that could suddenly collapse or shift positions. Make sure support material is solid, not decayed, warped, twisted, or tapered. Lower booms to ground level or on blocks. Lower booms and attachments to the ground before leaving the cab or operator's station.

WARNING!



USE CARE WITH HYDRAULIC FLUID PRESSURE

Hydraulic fluid under pressure can penetrate the skin and cause serious injury or death. Hydraulic leaks under pressure may not be visible. Before connecting or disconnecting hydraulic hoses, read your prime mover's operator's manual for detailed instructions on connecting and disconnecting hydraulic hoses or fittings.

- Keep unprotected body parts, such as face, eyes, and arms as far away as possible from a suspected leak. Flesh injected with hydraulic fluid may develop gangrene or other permanent disabilities.
- If injured by injected fluid, see a doctor at once. If your doctor is not familiar with this type of injury, ask him or her to research it immediately to determine proper treatment.
- Wear safety glasses, protective clothing, and use a piece of cardboard or wood when searching for hydraulic leaks. **DO NOT USE YOUR HANDS! SEE ILLUSTRATION.**

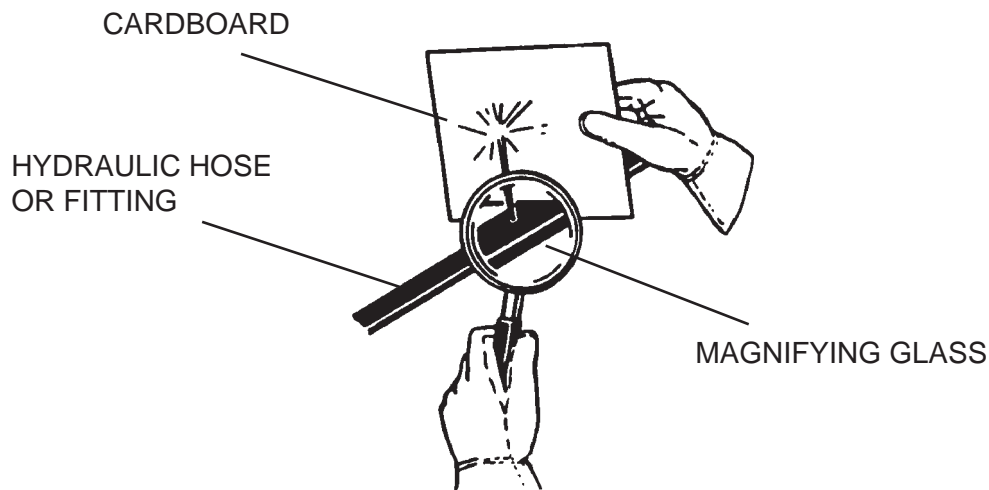

GENERAL SAFETY PRECAUTIONS

WARNING!



DO NOT MODIFY MACHINE OR ATTACHMENTS

Modifications may weaken the integrity of the attachment and may impair the function, safety, life, and performance of the attachment. When making repairs, use only the manufacturer's genuine parts, following authorized instructions. Other parts may be substandard in fit and quality. Never modify any ROPS (Roll Over Protection Structure) or FOPS (Falling Object Protective Structure) equipment or device. Any modifications must be authorized in writing by the manufacturer.

WARNING!



SAFELY MAINTAIN AND REPAIR EQUIPMENT

- Do not wear loose clothing or any accessories that can catch in moving parts. If you have long hair, cover or secure it so that it does not become entangled in the equipment.
- Work on a level surface in a well-lit area.
- Use properly grounded electrical outlets and tools.
- Use the correct tools for the job at hand. Make sure they are in good condition for the task required.
- Wear the protective equipment specified by the tool manufacturer.



SAFELY OPERATE EQUIPMENT

Do not operate equipment until you are completely trained by a qualified operator in how to use the controls, know its capabilities, dimensions, and all safety requirements. See your machine's manual for these instructions.

- Keep all step plates, grab bars, pedals, and controls free of dirt, grease, debris, and oil.
- Never allow anyone to be around the equipment when it is operating.
- Do not allow riders on the attachment or the prime mover.
- Do not operate the equipment from anywhere other than the correct operator's position.
- Never leave equipment unattended with the engine running, or with this attachment in a raised position.
- Do not alter or remove any safety feature from the prime mover or this attachment.
- Know your work site safety rules as well as traffic rules and flow. When in doubt on any safety issue, contact your supervisor or safety coordinator for an explanation.

EQUIPMENT SAFETY PRECAUTIONS

WARNING!



KNOW WHERE UTILITIES ARE

Observe overhead electrical and other utility lines. Be sure equipment will clear them. When digging, call your local utilities for location of buried utility lines, gas, water, and sewer, as well as any other hazard you may encounter.



OPERATING THE PRIME MOVER

Avoid steep hillside operation, which could cause the prime mover to overturn. Consult your machine operator's and safety manuals for maximum incline allowable.

When operating on a slope, keep the load low, and proceed with extreme caution. Do not drive ACROSS a steep slope - drive straight up and down.

With a LOADED attachment - face the attachment and load uphill.

With an EMPTY attachment - face the attachment downhill.



OPERATING THE SIDE SHIFT FORK CARRIAGE

- Do not exceed the lifting capacity of your prime mover and attachment. Always observe lift capacity limits listed in machine specifications or on load charts furnished with the prime mover.
- Always space the forks correctly for the load. Loads can fall off incorrectly spaced forks. Make sure the forks are completely under the load before lifting.
- Be careful when handling large/loose objects. Lifting too high or rolling forks too far back could result in these objects falling back on the operator. Unsecured loads can cause vehicle tipover, which can result in serious injury or death.
- Do not use the fork tines for prying or any purpose other than lifting.
- Never stack loads on uneven ground. Loads stacked on uneven ground can topple.
- Never lift a load with one fork. A load lifted with one fork can slip off and cause injury.
- Secure loads properly. Unsecured loads can fall unexpectedly. When transporting a load, keep the forks as close to the ground as possible.
- Keep the lifting surface of the forks level at all times.
- Do not handle round bales with fork lift tines.
- Don't obstruct your vision when traveling or working. Carry the forks low for maximum stability and visibility.
- When using the side shift feature to pick up a load, be sure to return the forks and load to the center position as soon as possible. Do NOT travel with loaded forks shifted to the side.
- If the carriage tilts or drifts due to oil leakage within the cylinder assembly, discontinue use until the problem has been corrected.
- Reduce speed when driving over rough terrain, on a slope, or turning, to avoid overturning the vehicle.
- Never use the attachment for a work platform or personnel carrier.
- An operator must not use drugs or alcohol, which can change his or her alertness or coordination. An operator taking prescription or over-the-counter drugs should seek medical advice on whether or not he or she can safely operate equipment.
- Before exiting the prime mover, lower the attachment to the ground, apply the brakes, turn off the prime mover's engine, and remove the key.

EQUIPMENT SAFETY PRECAUTIONS



EXPOSURE TO RESPIRABLE CRYSTALLINE SILICA DUST ALONG WITH OTHER HAZARDOUS DUSTS MAY CAUSE SERIOUS OR FATAL RESPIRATORY DISEASE.

It is recommended to use dust suppression, dust collection, and if necessary, personal protective equipment during the operation of any attachment that may cause high levels of dust.



TRANSPORTING THE SIDE SHIFT FORK CARRIAGE

- Travel only with the attachment in a safe transport position to prevent uncontrolled movement. Drive slowly over rough ground, and on slopes.
- When driving on public roads, use safety lights, reflectors, Slow Moving Vehicle signs, etc. to prevent accidents. Check local government regulations that may affect you.
- Do not drive close to ditches, excavations, etc., as a cave-in could result.
- Do not smoke when refueling the prime mover. Allow room in the fuel tank for expansion. Wipe up any spilled fuel, and secure cap tightly, when done.



MAINTAINING THE SIDE SHIFT FORK CARRIAGE

- Before performing maintenance, lower the attachment to the ground, apply the brakes, turn off the engine, and remove the key.
- Never perform any work on the equipment unless you are authorized and qualified to do so. Always read the operator's and service manual(s) before any repair is made. After completing maintenance or repair, check for correct functioning of the attachment. If not functioning properly, always attach a "DO NOT OPERATE" tag to the machine until all problems are corrected.
- Worn, damaged, or illegible safety decals must be replaced. New safety decals can be ordered from the manufacturer.
- Never make hydraulic repairs while the system is under pressure. Serious personal injury or death could result.
- Never work under a raised attachment.

INSTALLATION AND OPERATION

ATTACHING AND DETACHING SIDE SHIFT FORK CARRIAGE

Please see your vehicle operator's manual for instructions on attaching and detaching your equipment.

WARNING!



To prevent serious personal injury or death, only attach equipment that is designed for your vehicle.

Specified lift capacities must not be exceeded, otherwise machine stability will not be sufficient. Always observe lift capacity limits listed in machine specifications.

OPERATING SIDE SHIFT FORK CARRIAGE

- Read all Safety Precautions before operating your new attachment.
- For personal safety, lower the attachment to the ground, set the parking brake, shut off engine, and remove key before getting off of your prime mover.

SPECIAL OPERATING CONSIDERATIONS:

SIDE SHIFT FORK CARRIAGE OPERATION

When using the side shift feature to pick up a load, be sure to return the forks and loads to the center position as soon as possible. Do NOT travel with loaded forks shifted to the side.

CYLINDERS

IMPORTANT: If your hydraulically operated attachment tilts or starts to drift due to oil leakage within the cylinder assembly, discontinue use until the problem has been corrected.

INSTALLATION AND OPERATION

FORK CARRIAGE OPERATION

1. Approach the load in such a fashion that the weight will be centered between the fork tines. The heaviest side should be closest to the fork frame, and not near the tips of the fork tines.
2. Before lifting, make certain the fork tines are completely under the load, and level.
3. Lift the load slightly to make sure the load is stable. If the load appears unstable, lower and reposition the tines to achieve full stability.
4. Raise the telehandler to the MINIMUM height required for the terrain.
5. During material handling:
 - keep the fork tines level.
 - stop and start the telehandler gradually.
 - slow down before turning.
 - avoid obstacles, bumps, or holes.
6. Check the load frequently to ensure stability.

WARNING! Never exceed the recommended lifting capacity of any approved fork tines or the prime mover.



NOTE: Fork tine capacities are pounds per pair at a 24” load center. (The center of gravity of the allowable loads must be applied within the first 24” of the fork tines when measured from the front face of the vertical section of the fork tine out toward the tip of the horizontal section of the fork tine.)

WARNING! EXPOSURE TO RESPIRABLE CRYSTALLINE SILICA DUST ALONG WITH OTHER HAZARDOUS DUSTS MAY CAUSE SERIOUS OR FATAL RESPIRATORY DISEASE.



It is recommended to use dust suppression, dust collection and if necessary personal protective equipment during the operation of any attachment that may cause high levels of dust!

IMPORTANT

Concrete and masonry products contain silica sand. Quartz, which is a form of silica and the most common mineral in the earth's crust, is associated with many types of rock.

Some activities that silica dust may be present in the air include demolition, sweeping, loading, sawing, hammering, drilling or planing of rock, concrete or masonry.

It is recommended to use dust suppression (such as water), dust collection (such as a vacuum) along with personal protective equipment if necessary during the operation of any attachment that may cause high levels of silica dust.

INSTALLATION AND OPERATION TROUBLESHOOTING

ATTACHMENTS WITH HYDRAULICS

PROBLEM	POSSIBLE CAUSE	POSSIBLE REMEDY
Excessive oil temperature.	1. Hydraulic oil level too low.	• Refer to your vehicle operator's manual.
	2. Obstruction in hydraulic lines.	• Remove obstruction and replace, if necessary.
	3. Couplers not engaged correctly.	• Engage couplers.
	4. Hydraulic system overloaded, and system relief open.	• Reduce load.
A Hydraulic cylinder not operating.	1. Insufficient hydraulic flow from the prime mover.	• Refer to your vehicle operator's manual.
	2. Cylinder rod bent.	• Visually inspect the cylinder for damage.
	3. Cylinder seals damaged.	• Replace cylinder seals.
	4. Obstruction in hydraulic lines.	• Remove obstruction and replace, if necessary.

SIDE SHIFT FORK CARRIAGES

PROBLEM	POSSIBLE CAUSE	POSSIBLE REMEDY
Hydraulic cylinder not operating - carriage does not shift.	1. Hydraulic hoses incorrectly connected.	• Switch hoses on one cylinder.
	2. Insufficient hydraulic flow from the prime mover.	• Refer to your vehicle operator's manual.
	3. Cylinder rod bent.	• Visually inspect the cylinder for damage.
	4. Cylinder seals damaged.	• Replace cylinder seals.
	5. Obstruction in hydraulic lines.	• Remove obstruction and replace, if necessary.

MAINTENANCE & SERVICE

GENERAL INFORMATION

Regular maintenance is the key to long equipment life and safe operation. Maintenance requirements have been kept to an absolute minimum. However, it is very important that these maintenance functions be performed as described in this section.

DAILY

- Check all bolts and nuts for tightness.
- Replace any missing bolts or nuts with approved replacement parts.
- Check hydraulic system for hydraulic oil leaks. See procedure below.
- Visually inspect the machine for worn parts or cracked welds, and repair as necessary.

WARNING! Escaping fluid under pressure can have sufficient force to penetrate the skin, causing serious personal injury. Fluid escaping from a very small hole can be almost invisible. Use a piece of cardboard or wood, rather than hands to search for suspected leaks.



Keep unprotected body parts, such as face, eyes, and arms as far away as possible from a suspected leak. Flesh injected with hydraulic fluid may develop gangrene or other permanent disabilities.

If injured by injected fluid, see a doctor at once. If your doctor is not familiar with this type of injury, ask him or her to research it immediately to determine proper treatment.

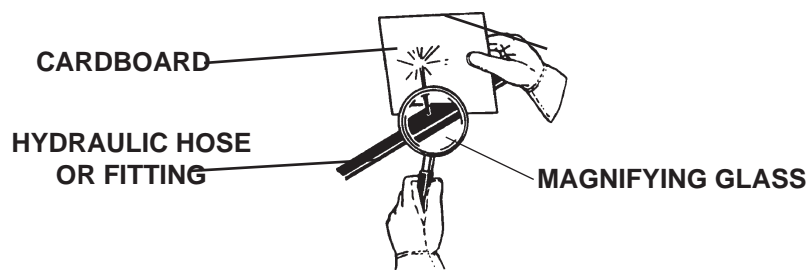

IMPORTANT: When replacing parts, use only factory approved replacement parts. Manufacturer will not claim responsibility for use of unapproved parts or accessories and/or other damages as a result of their use.

EVERY 40 HOURS

Lubrication is an important part of maintenance. It is recommended that all grease fittings be lubricated after the initial 8 hours of operation, and then after every 40 hours of use.

MAINTENANCE AND SERVICE

CYLINDER SEAL REPLACEMENT

The following information is provided to assist you in the event you should need to repair or rebuild a hydraulic cylinder. When working on hydraulic cylinders, make sure that the work area and tools are clean and free of dirt to prevent contamination of the hydraulic system and damage to the hydraulic cylinders. Always protect the active part of the cylinder rod (the chrome section). Nicks or scratches on the surface of the rod could result in cylinder failure. Clean all parts thoroughly with a cleaning solvent before reassembly.

DISASSEMBLY PROCEDURE

IMPORTANT: Do not contact the active surface of the cylinder rod with the vise. Damage to the rod could result.

THREADED TYPE GLAND

1. Rotate the gland with a spanner wrench counterclockwise until the gland is free of the cylinder tube.
2. Pull the cylinder rod from the cylinder tube and inspect the piston and the bore of the cylinder tube for deep scratches or galling. If damaged, the piston AND the cylinder tube must be replaced.

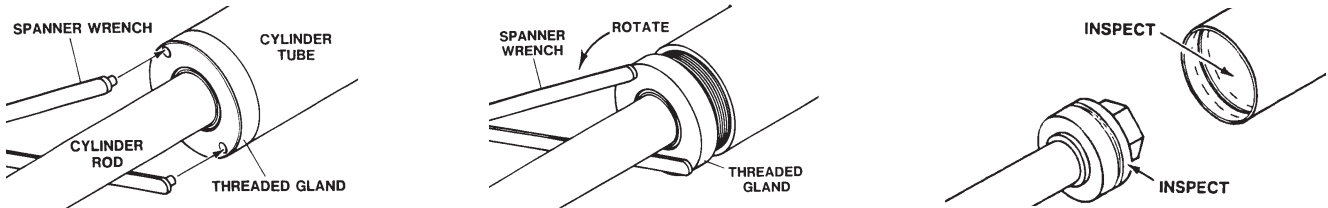

3. Remove the hex nut, piston, flat washer or spacer tube (if so equipped), and gland from the cylinder rod. If the cylinder rod is rusty, scratched, or bent, it must be replaced.
4. Remove and discard all the old seals.



ASSEMBLY PROCEDURE

IMPORTANT: Replace all seals even if they do not appear to be damaged. Failure to replace all seals may result in premature cylinder failure. **NOTE:** Seal kits will service most cylinders of similar bore size and rod diameter.

1. Install the cylinder rod seal in the gland first. Be careful not to damage the seal in the process, as it is somewhat difficult to install.

NOTE: A special installation tool (Part #65349) is available to help with installing the seal. Simply fit the end of the tool over the seal so that the large prong of the tool is on the outside of the seal, and the two smaller prongs on the inside. The lip of the seal should be facing towards the tool. Rotate the handles on the tool around to wrap the seal around the end of the tool.

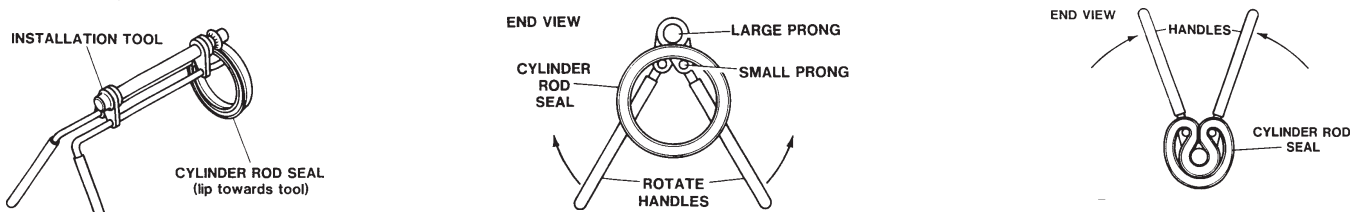

10356 10-13-05

MAINTENANCE AND SERVICE

Now insert the seal into the gland from the inner end. Position the seal in its groove, and release and remove the tool. Press the seal into its seat the rest of the way by hand.

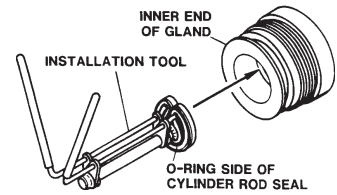

2. Install the new piston ring, rod wiper, O-rings and backup washers, if applicable, on the piston.

Be careful not to damage the seals. Caution must be used when installing the piston ring. The ring must be stretched carefully over the piston with a smooth, round, pointed tool.

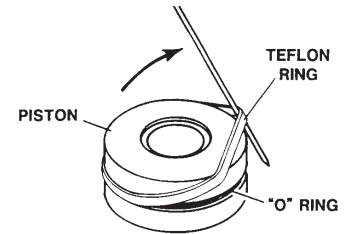

3. After installing the rod seal inside the gland, as shown in step #1, install the external seal.

NOTE: Threaded glands may have been equipped with a separate O-ring and backup washer system or a polypak (all in one) type seal. Current seal kits contain a polypak (all in one) type seal to replace the discarded seal types on ALL THREADED GLANDS.

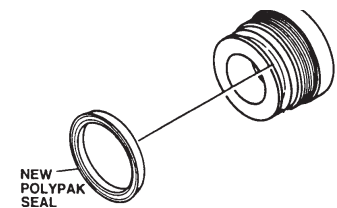

4. Slide the gland onto the cylinder rod, being careful not to damage the rod wiper. Then install the spacer, or flat washer (if so equipped), small o-ring, piston, and hex nut onto the end of the cylinder rod.
5. Secure the cylinder rod (mounting end) in a vise with a support at its center. Torque the nut to the amount shown for the thread diameter of the cylinder rod (see chart).

Thread Diameter	POUNDS - FEET
7/8"	150-200
*1"	230-325
1-1/8"	350-480
1-1/4"	490-670
1-3/8"	670-900
* 1" Thread Diameter WITH 1.25" Rod Diameter Min. 230 ft. lbs. Max. 250 ft. lbs.	

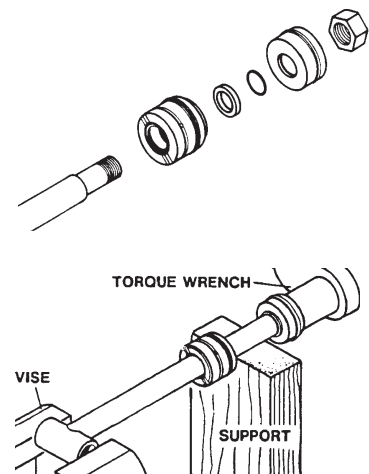

IMPORTANT: Do not contact the active surface of the cylinder rod with the vise. Damage to the rod could result.

6. Apply a lubricant (such as Lubriplate #105) to the piston and teflon ring. Insert the cylinder rod assembly into the cylinder tube.

IMPORTANT: Ensure that the piston ring fits squarely into the cylinder tube and piston groove, otherwise the ring may be damaged and a leak will occur.

7. Use a spanner wrench to rotate the gland clockwise into the cylinder. Continue to rotate the gland with the spanner wrench until it is tight.

WARNING! Cylinders serviced in the field are to be tested for leakage prior to the attachment being placed in work. Failure to test rebuilt cylinders could result in damage to the cylinder and/or the attachment, cause severe personal injury or even death.



SPECIFICATIONS

SIDE SHIFT FORK CARRIAGE SPECIFICATIONS			
	<u>11324</u>	<u>11510</u>	<u>12319</u>
Overall Height (inches) Without Forks	40.50	45.25	39.38
Overall Width (inches)	49.00	75.50	67.78
Side Shift on Each Side of Center (inches)	4.00	4.00	4.00
Total Overall Side Shift Movement (inches)	8.00	8.00	8.00
Attachment Weight - Without Forks (lbs.)	640	826	897
Shipping Weight - Without Forks (lbs.)	690	876	947
	<u>12426</u>	<u>12540</u>	<u>12633</u>
Overall Height (inches) Without Forks	44.49	38.40	43.87
Overall Width (inches)	46.75	49.25	51.00
Side Shift on Each Side of Center (inches)	4.00	4.00	4.00
Total Overall Side Shift Movement (inches)	8.00	8.00	8.00
Attachment Weight - Without Forks (lbs.)	683	604	680
Shipping Weight - Without Forks (lbs.)	733	654	730
	<u>12644</u>	<u>12659</u>	<u>12703</u>
Overall Height (inches) Without Forks	49.80	44.83	44.80
Overall Width (inches)	49.51	51.00	59.00
Side Shift on Each Side of Center (inches)	4.00	4.00	4.00
Total Overall Side Shift Movement (inches)	8.00	8.00	8.00
Attachment Weight - Without Forks (lbs.)	590	963	1052
Shipping Weight - Without Forks (lbs.)	640	1013	1102
	<u>12966</u>	<u>12965</u>	
Overall Height (inches) Without Forks	45.25	45.25	
Overall Width (inches)	49.00	75.50	
Side Shift on Each Side of Center (inches)	4.00	4.00	
Total Overall Side Shift Movement (inches)	8.00	8.00	
Attachment Weight - Without Forks (lbs.)	710	826	
Shipping Weight - Without Forks (lbs.)	760	876	



BOLT TORQUE SPECIFICATIONS

GENERAL TORQUE SPECIFICATION TABLES

Use the following charts when determining bolt torque specifications when special torques are not given. Always use grade 5 or better when replacing bolts.



SAE BOLT TORQUE SPECIFICATIONS

NOTE: The following torque values are for use with extreme pressure lubricants, plating or hard washer applications. Increase torque 15% when using hardware that is unplated and either dry or lubricated with engine oil.

Bolt Size		SAE GRADE 5 TORQUE				SAE GRADE 8 TORQUE				Bolt head identification marks as per grade. NOTE: Manufacturing Marks Will Vary
		Pounds Feet		Newton-Meters		Pounds Feet		Newton-Meters		
Inches	Millimeters	UNC	UNF	UNC	UNF	UNC	UNF	UNC	UNF	
1/4	6.35	8	9	11	12	10	13	14	18	<p>GRADE 2</p>  <p>GRADE 5</p>  <p>GRADE 8</p> 
5/16	7.94	14	17	19	23	20	25	27	34	
3/8	9.53	30	36	41	49	38	46	52	62	
7/16	11.11	46	54	62	73	60	71	81	96	
1/2	12.70	68	82	92	111	94	112	127	152	
9/16	14.29	94	112	127	152	136	163	184	221	
5/8	15.88	128	153	174	207	187	224	254	304	
3/4	19.05	230	275	312	373	323	395	438	536	
7/8	22.23	340	408	461	553	510	612	691	830	
1	25.40	493	592	668	803	765	918	1037	1245	
1-1/8	25.58	680	748	922	1014	1088	1224	1475	1660	
1-1/4	31.75	952	1054	1291	1429	1547	1700	2097	2305	
1-3/8	34.93	1241	1428	1683	1936	2023	2312	2743	3135	
1-1/2	38.10	1649	1870	2236	2535	2686	3026	3642	4103	

METRIC BOLT TORQUE SPECIFICATIONS

NOTE: The following torque values are for use with metric hardware that is unplated and either dry or lubricated with engine oil. Reduce torque 15% when using hardware that has extreme pressure lubricants, plating or hard washer applications.

Bolt head identification marks as per grade.		
		

Size of Bolt	Grade No.	Pitch (mm)	Pounds Feet	Newton-Meters	Pitch (mm)	Pounds Feet	Newton-Meters
M6	5.6	1.0	3.6-5.8	4.9-7.9	-	-	-
	8.8		5.8-4	7.9-12.7		-	-
	10.9		7.2-10	9.8-13.6		-	-
M8	5.6	1.25	7.2-14	9.8-19	1.0	12-17	16.3-23
	8.8		17-22	23-29.8		19-27	25.7-36.6
	10.9		20-26	27.1-35.2		22-31	29.8-42
M10	5.6	1.5	20-25	27.1-33.9	1.25	20-29	27.1-39.3
	8.8		34-40	46.1-54.2		35-47	47.4-63.7
	10.9		38-46	51.5-62.3		40-52	54.2-70.5
M12	5.6	1.75	28-34	37.9-46.1	1.25	31-41	42-55.6
	8.8		51-59	69.1-79.9		56-68	75.9-92.1
	10.9		57-66	77.2-89.4		62-75	84-101.6
M14	5.6	2.0	49-56	66.4-75.9	1.5	52-64	70.5-86.7
	8.8		81-93	109.8-126		90-106	122-143.6
	10.9		96-109	130.1-147.7		107-124	145-168
M16	5.6	2.0	67-77	90.8-104.3	1.5	69-83	93.5-112.5
	8.8		116-130	157.2-176.2		120-138	162.6-187
	10.9		129-145	174.8-196.5		140-158	189.7-214.1
M18	5.6	2.0	88-100	119.2-136	1.5	100-117	136-158.5
	8.8		150-168	203.3-227.6		177-199	239.8-269.6
	10.9		175-194	237.1-262.9		202-231	273.7-313
M20	5.6	2.5	108-130	146.3-176.2	1.5	132-150	178.9-203.3
	8.8		186-205	252-277.8		206-242	279.1-327.9
	10.9		213-249	288.6-337.4		246-289	333.3-391.6

STORAGE

GENERAL INFORMATION

The following storage procedure will help you to keep your attachment in top condition. It will also help you get off to a good start the next time your equipment is needed. We therefore strongly recommend that you take the extra time to follow these procedures whenever your attachment will not be used for an extended period of time.

PREPARATION FOR STORAGE

1. Clean the attachment thoroughly, removing all mud, dirt, and grease.
2. Inspect for visible signs of wear, breakage, or damage. Order any parts required, and make the necessary repairs, to avoid delays when starting next season.
3. Tighten all loose nuts, capscrews, and hydraulic connections.
4. Lubricate all grease fittings.
5. Coat the exposed portions of the cylinder rods with grease.
6. Connect the hydraulic couplers together to protect the hydraulic system from contaminants.
7. Touch up all unpainted and exposed areas with paint, to prevent rust.
8. Replace decals, if damaged or in unreadable condition.
9. Store the attachment in a dry and protected place, with a cover, if possible. Leaving the attachment outside will materially shorten its life.

REMOVING FROM STORAGE

1. Remove all protective coverings.
2. Check hydraulic hoses for deterioration, and replace if necessary.

LIMITED WARRANTY

All new Major products are warranted to be free from defects in materials or workmanship which may cause failure under normal usage and service, when used for the purpose intended.

In the event of failure within twelve (12) months from initial retail sale, lease or rental date (excluding cable, ground engaging parts such as sprockets, digging chain, bearings, teeth, tamping and demolition heads, blade cutting edges, pilot bits, auger teeth, auger heads & broom bristles), if after examination, The Major determines failure was due to defective material and/or workmanship, parts will be repaired or replaced. The Major may request defective part or parts be returned prepaid to them for inspection at their place of business at Delhi, Iowa, or to a location specified by The Major.

Any claims under this warranty must be made within fifteen (15) days after the Buyer learns of the facts upon which such claim is based. All claims not made in writing and received by The Major within the time period specified above shall be deemed waived.

THIS WARRANTY IS IN LIEU OF ALL OTHER WARRANTIES EXPRESSED OR IMPLIED, AND THERE ARE NO WARRANTIES OF MERCHANTABILITY OR OF FITNESS FOR A PARTICULAR PURPOSE. IN NO EVENT SHALL THE MAJOR BE LIABLE FOR CONSEQUENTIAL OR SPECIAL DAMAGE.

THE MAJOR'S LIABILITY FOR ANY AND ALL LOSSES AND DAMAGES TO BUYER, RESULTING FROM ANY CAUSE WHATSOEVER, INCLUDING THE MAJOR'S NEGLIGENCE, IRRESPECTIVE OF WHETHER SUCH DEFECTS ARE DISCOVERABLE OR LATENT, SHALL IN NO EVENT EXCEED THE PURCHASE PRICE OF THE PARTICULAR PRODUCTS WITH RESPECT TO WHICH LOSSES OR DAMAGES ARE CLAIMED, OR, AT THE ELECTION OF THE MAJOR, THE REPAIR OR REPLACEMENT OF DEFECTIVE OR DAMAGED PRODUCTS.

PARTS

The following section contains detailed diagrams and parts lists which include your attachment. Please use these diagrams and parts lists to locate replacement parts, prior to contacting the parts department.

When servicing your attachment, remember to use only original manufacturer replacement parts. Substitute parts may not meet the standards required for safe, dependable operation.

To facilitate parts ordering, have the model and serial number of your product ready, to ensure that you receive the correct parts for your specific attachment.

The model and serial number for your attachment should be recorded in the space provided on the cover of this manual. This information may be obtained from the serial number identification plate located on your attachment. **See the parts diagram for your attachment for the location.**

NOTE: Most daily and emergency orders received by 2:00 P.M. will be shipped the same day received, with “Emergency-Machine-Down” orders receiving first priority.



PARTS DEPARTMENT

(563) 922-2981

(800) 922-2981

We Encourage Fax Orders

(563) 922-2593

FORK CARRIAGE

48" SIDE SHIFT - ASSEMBLY #11324



WARNING

High-PRESSURE FLUID HAZARD

To prevent serious injury or death:

- Relieve pressure on system before repairing or servicing.
- Wear proper hand and eye protection when searching for leaks. Use wood or cardboard instead of hands.
- Keep all components in good repair.

KEEP AWAY

DANGER

To prevent serious injury or death from pinching:

- Keep all persons and objects clear while any part of this machine is in motion.

KEEP AWAY

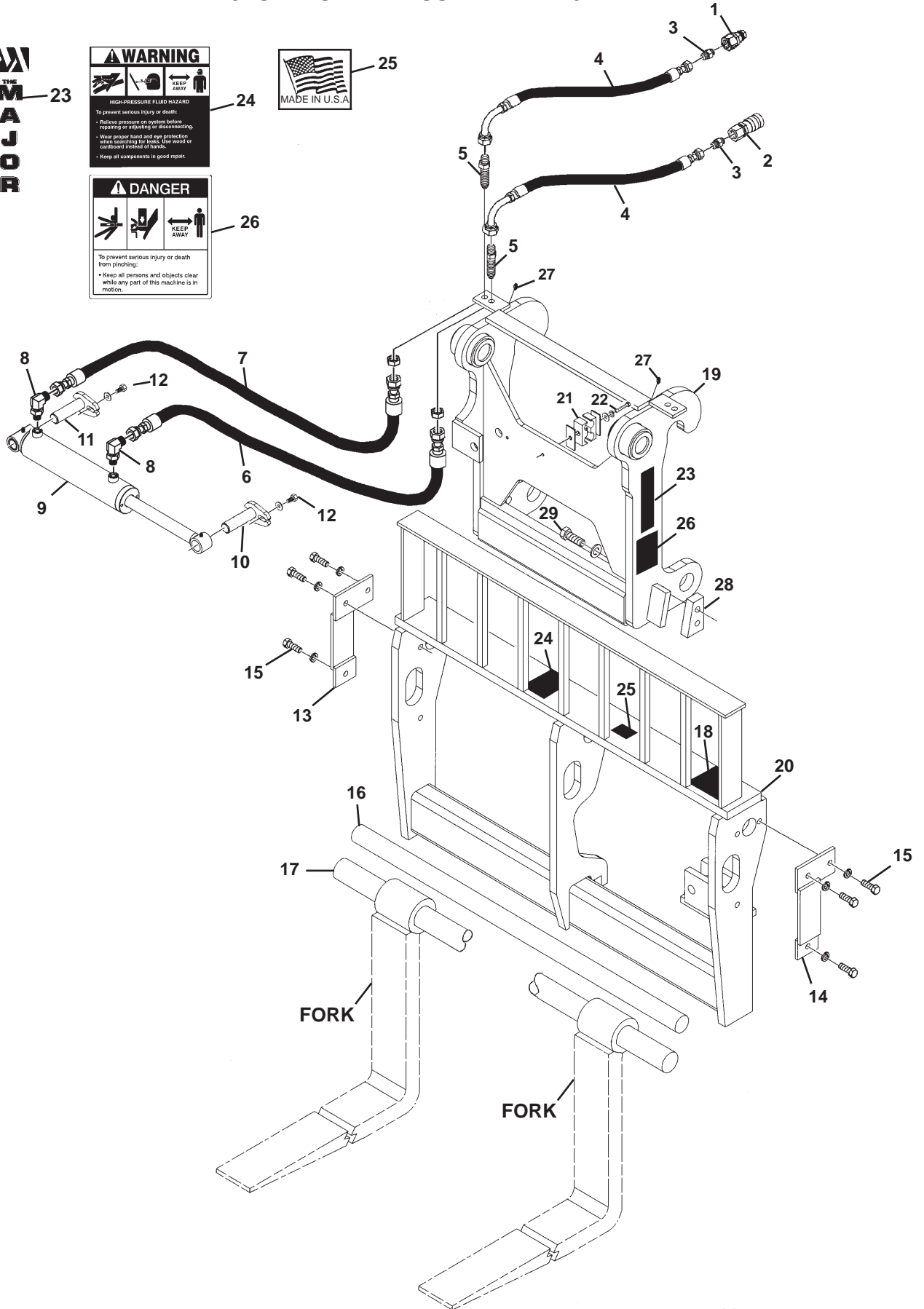

FORK CARRIAGE

48" SIDE SHIFT - ASSEMBLY #11324

<u>ITEM</u>	<u>QTY.</u>	<u>PART NO.</u>	<u>DESCRIPTION</u>
1	1	22519	Male Quick Coupler
2	1	22518	Female Quick Coupler
3	2	30201	Straight Connector, 12MBo-6MJ
4	2	37893	Hose .38" X 40" 6FJX-6FJX90°
5	2	3297	Bulkhead Straight Connector, 6MJ-6MJ
6	1	37838	Hose .38" X 28" 6FJX-6FJX
7	1	37492	Hose .38" X 40" 6FJX-6FJX
8	2	3434	90° Elbow, 6MBo-6MJ
9	1	88920	Cylinder Assembly
10	1	14071	Pin, 1.00" x 3.31"
11	1	100770	Pin, 1.00" x 4.00"
12	2	10023	.31" UNF x 1.00" Hex Capscrew
	2	1513	.31" Flat Washer
13	1	32547	Right Pin Retainer
14	1	32470	Left Pin Retainer
15	6	1090	.50" UNC x 1.50" Hex Capscrew
	6	1505	.50" Lock Washer
16	1	32493	Side Shift Pin, 2.00" x 47.75"
17	1	14262	Fork Pin, 60MM x 48.50"
18	1	-----	Serial Number Identification Tag Location
19	1	32468	Rear Frame
20	1	32469	Front Frame
21	1	81358	Hose Clamp
22	1	10023	.31" UNF x 1.00" Hex Capscrew
	1	1513	.31" Flat Washer
23	2	40501	Major Logo, Small
24	1	40151	High Pressure Warning Decal
25	1	4338	Made in USA Decal
26	2	40149	Pinch Point Danger Decal
27	2	6133	Grease Zerk
28	2	14228	Stop Block
29	4	10012	.75" UNC x 2.25" Hex Capscrew, Grade 8
	4	1507	.75" Lock Washer

***CONTACT YOUR DEALER FOR TINES AVAILABLE FOR YOUR ATTACHMENT.**

FORK CARRIAGE

48" SIDE SHIFT - ASSEMBLY #12426



13



16



17

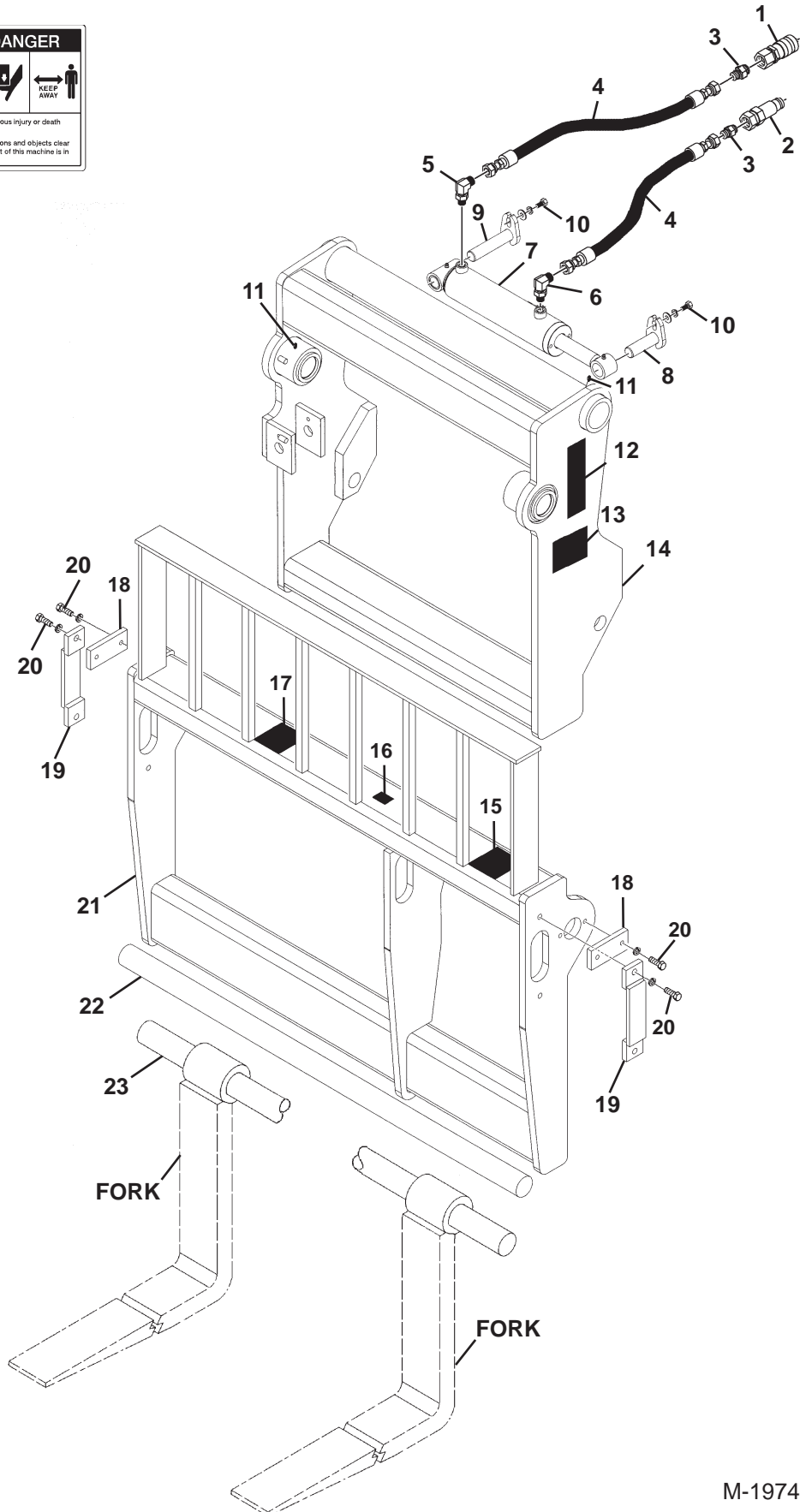

FORK CARRIAGE
48" SIDE SHIFT - ASSEMBLY #12426

<u>ITEM</u>	<u>QTY.</u>	<u>PART NO.</u>	<u>DESCRIPTION</u>
1	1	22518	Female Quick Coupler
2	1	22519	Male Quick Coupler
3	2	30201	Straight Connector, 12MBo-6MJ
4	2	14397	Hose .38" X 69" 6FJX-6FJX
5	1	3434	90° Elbow, 6MBo-6MJ
6	1	14067	90° Elbow, W/.027 Orifice, 6MBo-6MJ
7	1	88928	Cylinder Assembly
8	1	14071	Pin, 1.00" x 3.31"
9	1	14070	Pin, 1.00" x 4.72"
10	2	1293	.38" UNF x 1.00" Hex Capscrew
	2	1503	.38" Lock Washer
	2	1514	.38" Flat Washer
11	2	9371	Grease Zerk
12	2	40501	Major Logo, Small
13	2	40149	Decal, Pinch Point
14	1	16842	Rear Frame
15	1	-----	Serial Number Identification Tag Location
16	1	4338	Made in USA Decal
17	1	40151	High Pressure Warning Decal
18	1	16851	Side Shift Pin Retainer
19	1	14002	Fork Pin Retainer
20	8	1339	.50" UNF x 1.25" Hex Capscrew
	8	1505	.50" Lock Washer
21	1	16841	Front Frame
22	1	16846	Side Shift Pin, 2.00" x 48.25"
23	1	15244	Fork Pin, 2.00" x 49.00"

***CONTACT YOUR DEALER FOR TINES AVAILABLE FOR YOUR ATTACHMENT.**

FORK CARRIAGE

48" SIDE SHIFT - ASSEMBLY #12633

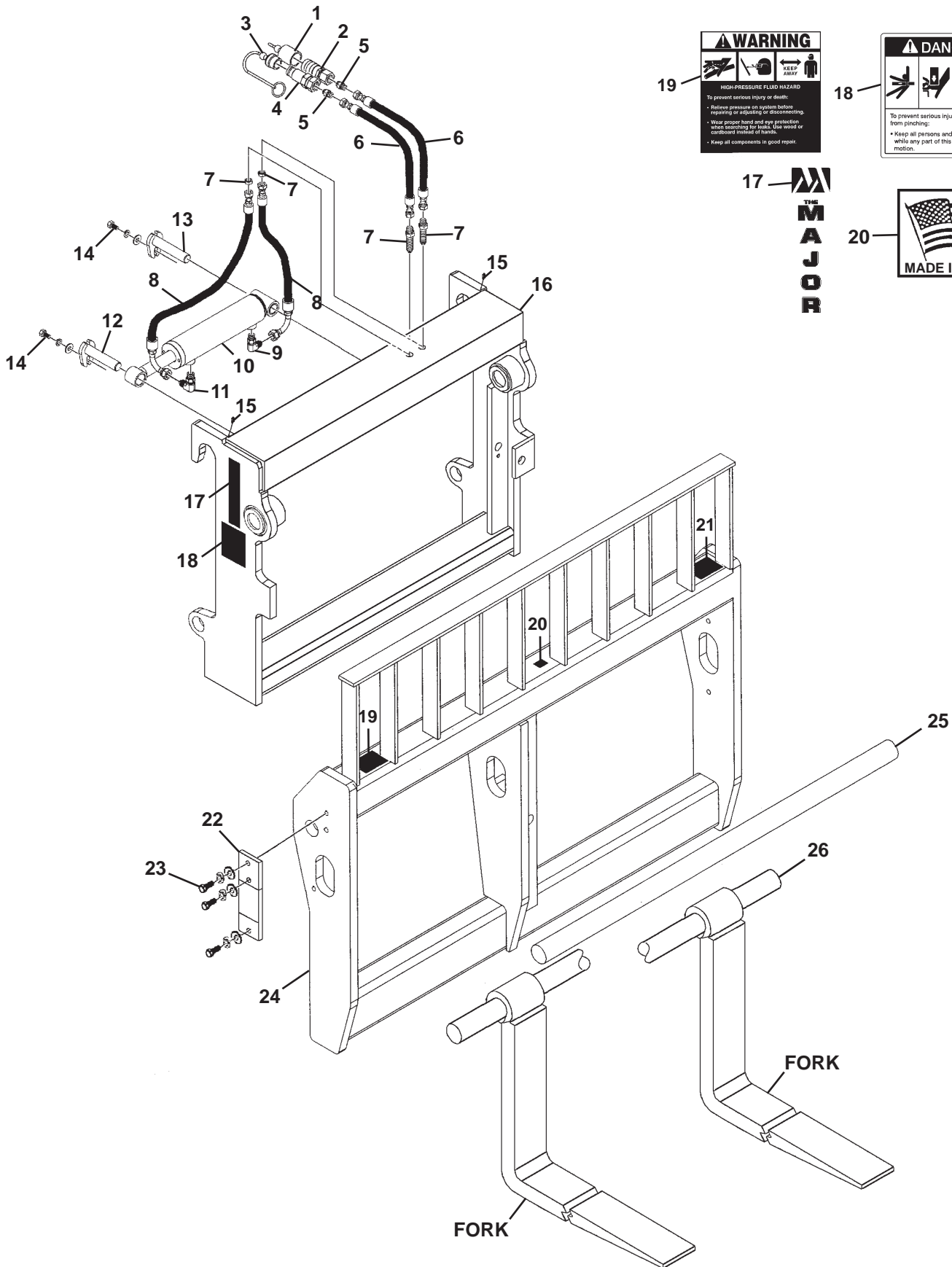

WARNING

HIGH-PRESSURE FLUID HAZARD

To prevent serious injury or death:

- Relieve pressure on system before repairing or adjusting or disconnecting.
- Wear proper hand and eye protection when servicing or loading. Use wood or cardboard instead of hands.
- Keep all components in good repair.

DANGER

To prevent serious injury or death from pinching:

- Keep all persons and objects clear while any part of this machine is in motion.

THE MAJOR



FORK CARRIAGE
48" SIDE SHIFT - ASSEMBLY #12633

<u>ITEM</u>	<u>QTY.</u>	<u>PART NO.</u>	<u>DESCRIPTION</u>
1	1	32548	Dust Cover
2	1	84928	Female Quick Coupler
3	1	32549	Dust Cover
4	1	84923	Male Quick Coupler
5	2	3269	Straight Connector, 8MBo-6MJ
6	2	37887	Hose .38" X 64" 6FJX-6FJX
7	2	3297	Bulkhead Connector, 6MJ-6MJ
8	2	37862	Hose .38" X 23.25" 6FJX-6FJX90°
9	1	3434	90° Elbow, 6MBo-6MJ
10	1	88928	Cylinder Assembly
11	1	14067	90° Elbow, W/.027 Orifice, 6MBo-6MJ
12	1	31990	Pin, 1.00" x 4.50"
13	1	14070	Pin, 1.00" x 4.72"
14	2	1293	.38" UNF x 1.00" Hex Capscrew
	2	1503	.38" Lock Washer
	2	1514	.38" Flat Washer
15	2	9371	Grease Zerk
16	1	33530	Rear Frame
17	2	40501	Major Logo, Small
18	2	40149	Decal, Pinch Point
19	1	40151	High Pressure Warning Decal
20	1	4338	Made in USA Decal
21	1	-----	Serial Number Identification Tag Location
22	1	33554	Pin Retainer
23	3	1339	.50" UNF x 1.25" Hex Capscrew
	3	1505	.50" Lock Washer
	3	1516	.50" Flat Washer
24	1	33531	Front Frame
25	1	33549	Side Shift Pin, 2.00" x 53.00"
26	1	33550	Fork Pin, 2.25" x 53.50"

***CONTACT YOUR DEALER FOR TINES AVAILABLE FOR YOUR ATTACHMENT.**

FORK CARRIAGE

48" SIDE SHIFT - ASSEMBLY #12540

WARNING

HIGH-PRESSURE FLUID HAZARD

To prevent serious injury or death:

- Relieve pressure on system before repairing or adjusting or disconnecting.
- Wear proper hand and eye protection when searching for leaks. Use wood or cardboard instead of hands.
- Keep all components in good repair.



DANGER

To prevent serious injury or death from pinching:

- Keep all persons and objects clear while any part of this machine is in motion.

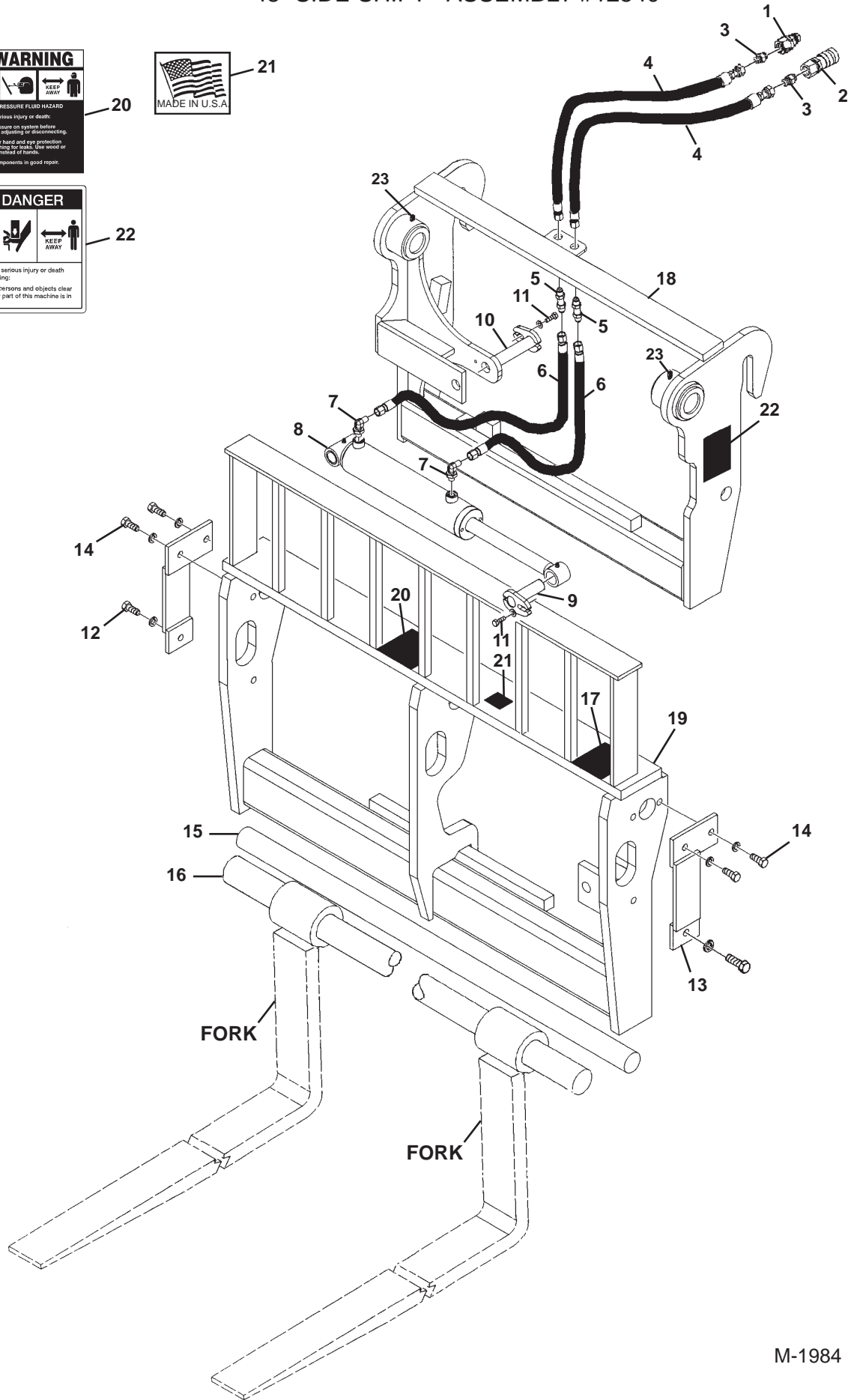

FORK CARRIAGE
48" SIDE SHIFT - ASSEMBLY #12540

<u>ITEM</u>	<u>QTY.</u>	<u>PART NO.</u>	<u>DESCRIPTION</u>
1	1	22519	Male Quick Coupler
2	1	22518	Female Quick Coupler
3	2	30201	Straight Connector, 12MBo-6MJ
4	2	35424	Hose .38" X 76" 6FJX-6FJX
5	2	3297	Bulkhead Straight Connector, 6MJ-6MJ
6	2	38036	Hose .38" X 15" 6FJX-6FJX
7	2	3434	90° Elbow, 6MBo-6MJ
8	1	88920	Cylinder Assembly
9	1	14071	Pin, 1.00" x 3.31"
10	1	31990	Pin, 1.00" x 4.50"
11	2	10023	.31" UNF x 1.00" Hex Capscrew
	2	1513	.31" Flat Washer
12	1	32547	Right Pin Retainer
13	1	32470	Left Pin Retainer
14	6	1090	.50" UNC x 1.50" Hex Capscrew
	6	1505	.50" Lock Washer
15	1	32493	Side Shift Pin, 2.00" x 47.75"
16	1	104880	Fork Pin, 2.25" x 48.38"
17	1	----	Serial Number Identification Tag Location
18	1	19039	Rear Frame
19	1	19040	Front Frame
20	1	40151	High Pressure Warning Decal
21	1	4338	Made in USA Decal
22	2	40149	Pinch Point Danger Decal
23	2	6133	Grease Zerk

***CONTACT YOUR DEALER FOR TINES AVAILABLE FOR YOUR ATTACHMENT.**

FORK CARRIAGE

48" SIDE SHIFT - ASSEMBLY #12644



19



20



22



23

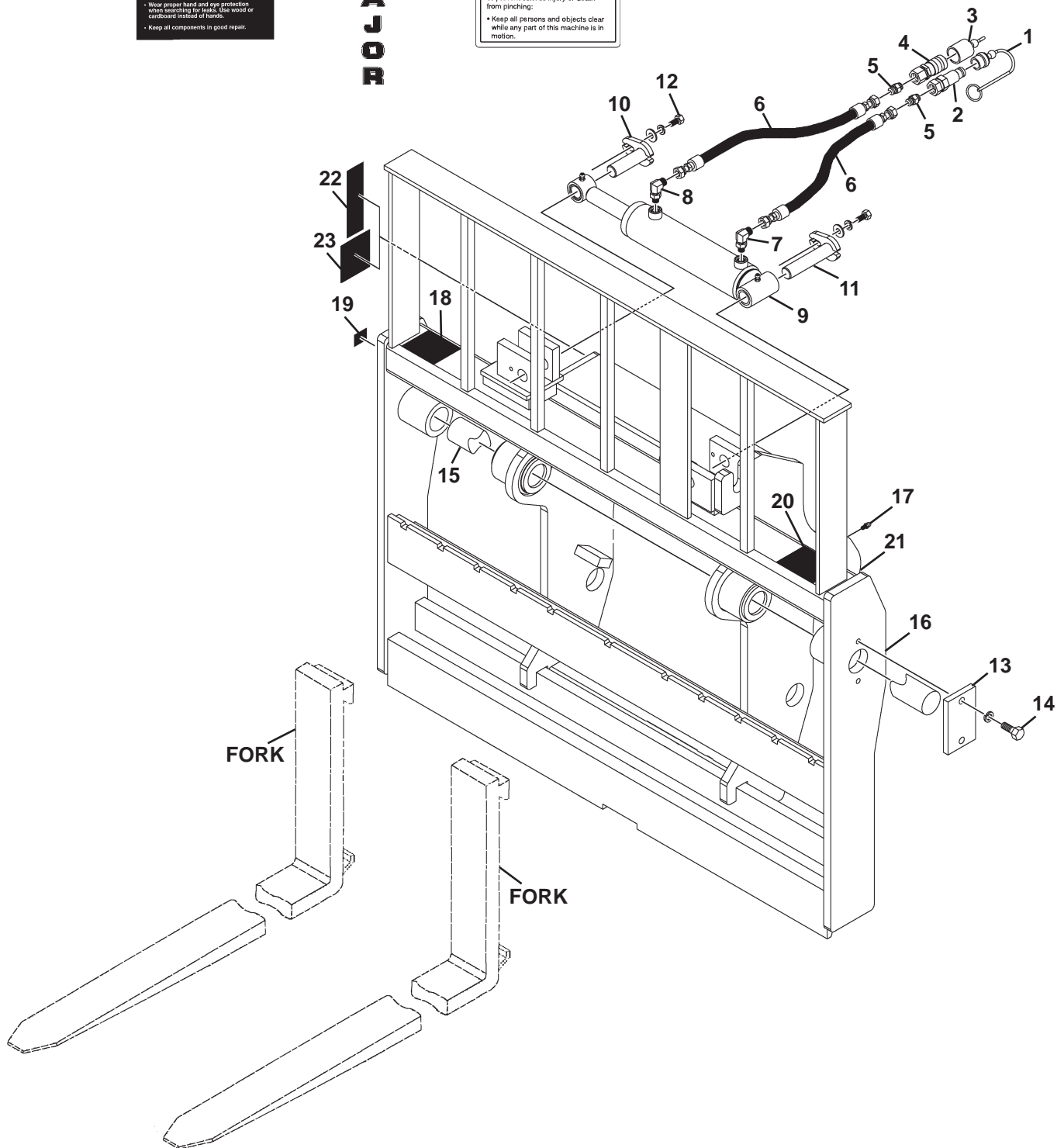

FORK

FORK

FORK CARRIAGE

48" SIDE SHIFT - ASSEMBLY #12644

<u>ITEM</u>	<u>QTY.</u>	<u>PART NO.</u>	<u>DESCRIPTION</u>
1	1	32549	Male Dust Cover
2	1	84923	Male Quick Coupler
3	1	32548	Female Dust Cover
4	1	84928	Female Quick Coupler
5	2	3269	Straight Connector, 8MBo-6MJ
6	2	37839	Hose .38" X 50" 6FJX-6FJX
7	1	3434	90° Elbow, 6MBo-6MJ
8	1	30259	90° Elbow, 6MBo-6MJ With 0.60" Orifice
9	1	88928	Cylinder Assembly
10	1	14071	Pin, 1.00" x 3.31"
11	1	14070	Pin, 1.00" x 4.72"
12	2	1043	.38" UNC x 1.00" Hex Capscrew
	2	1514	.38" Flat Washer
	2	1503	.38" Lock Washer
13	1	14606	Pin Retainer
14	2	1089	.50" UNC x 1.25" Hex Capscrew
	2	1505	.50" Lock Washer
15	1	24506	Side Shift Pin, 2.00" x 49.50"
16	1	24495	Front Frame
17	2	9371	Grease Zerk
18	1	----	Serial Number Identification Tag Location
19	1	4338	Made in USA Decal
20	1	40151	High Pressure Warning Decal
21	1	24496	Rear Frame
22	2	40501	Major Logo, Small
23	2	40149	Pinch Point Danger Decal

***CONTACT YOUR DEALER FOR TINES AVAILABLE FOR YOUR ATTACHMENT.**

FORK CARRIAGE

48" SIDE SHIFT - ASSEMBLY #12659

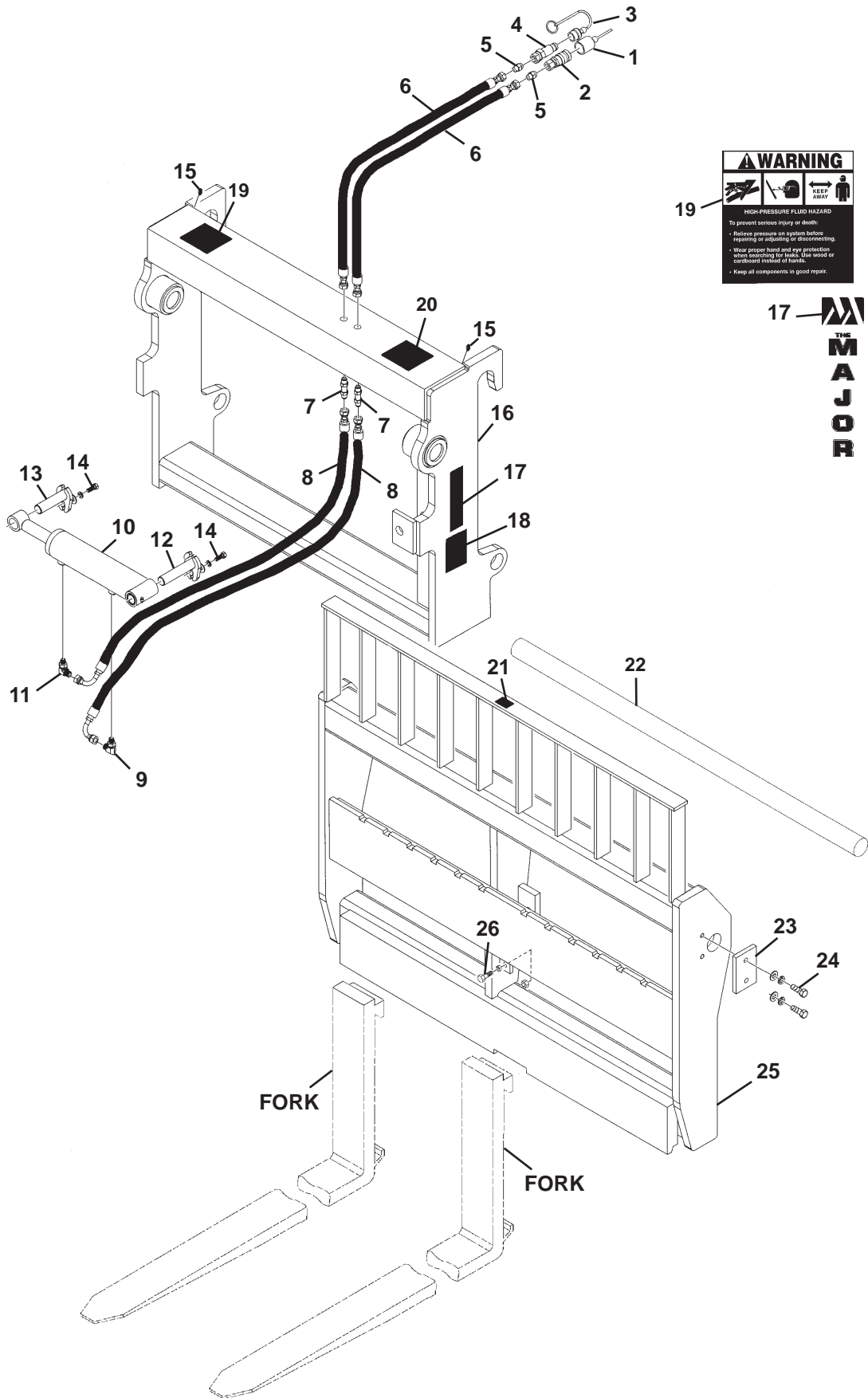

WARNING

HIGH-PRESSURE FLUID HAZARD

To prevent serious injury or death:

- Relieve pressure on system before repairing or adjusting, or disconnecting.
- Wear proper hand and eye protection when searching for leaks. Use wood or cardboard instead of hands.
- Keep all components in good repair.

⚠ DANGER

To prevent serious injury or death from pinching:

- Keep all persons and objects clear while any part of this machine is in motion.

THE MAJOR

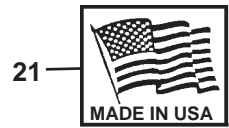

FORK CARRIAGE
48" SIDE SHIFT - ASSEMBLY #12659

<u>ITEM</u>	<u>QTY.</u>	<u>PART NO.</u>	<u>DESCRIPTION</u>
1	1	32548	Dust Cover
2	1	84928	Female Quick Coupler
3	1	32549	Dust Cover
4	1	84923	Male Quick Coupler
5	2	3269	Straight Connector, 8MBo-6MJ
6	2	37887	Hose .38" X 64" 6FJX-6FJX
7	2	3297	Bulkhead Connector, 6MJ-6MJ
8	2	37862	Hose .38" X 23.25" 6FJX-6FJX90°
9	1	3434	90° Elbow, 6MBo-6MJ
10	1	88928	Cylinder Assembly
11	1	14067	90° Elbow, W/.027 Orifice, 6MBo-6MJ
12	1	31990	Pin, 1.00" x 4.50"
13	1	12054	Pin, 1.00" x 3.75"
14	2	1293	.38" UNF x 1.00" Hex Capscrew
	2	1503	.38" Lock Washer
	2	1514	.38" Flat Washer
15	2	9371	Grease Zerk
16	1	33530	Rear Frame
17	2	40501	Major Logo, Small
18	2	40149	Pinch Point Decal
19	1	40151	High Pressure Warning Decal
20	1	----	Serial Number Identification Tag Location
21	1	4338	Made in USA Decal
22	1	33549	Side Shift Pin, 2.00" x 53.00"
23	1	33541	Pin Retainer
24	2	1339	.50" UNF x 1.25" Hex Capscrew
	2	1505	.50" Lock Washer
	2	1516	.50" Flat Washer
25	1	100974	Front Frame
26	1	1089	.50" UNC x 1.25" Hex Capscrew
	1	86149	Spacer
	1	1228	.50" UNC Hex Nut

***CONTACT YOUR DEALER FOR TINES AVAILABLE FOR YOUR ATTACHMENT.**

FORK CARRIAGE

48" SIDE SHIFT - ASSEMBLY #12966

WARNING

HIGH-PRESSURE FLUID HAZARD

To prevent serious injury or death:

- Relieve pressure on system before repairing or adjusting or disconnecting.
- Wear proper hand and eye protection when searching for leaks. Use wood or cardboard instead of hands.
- Keep all components in good repair.



DANGER

To prevent serious injury or death from pinching:

- Keep all persons and objects clear while any part of this machine is in motion.

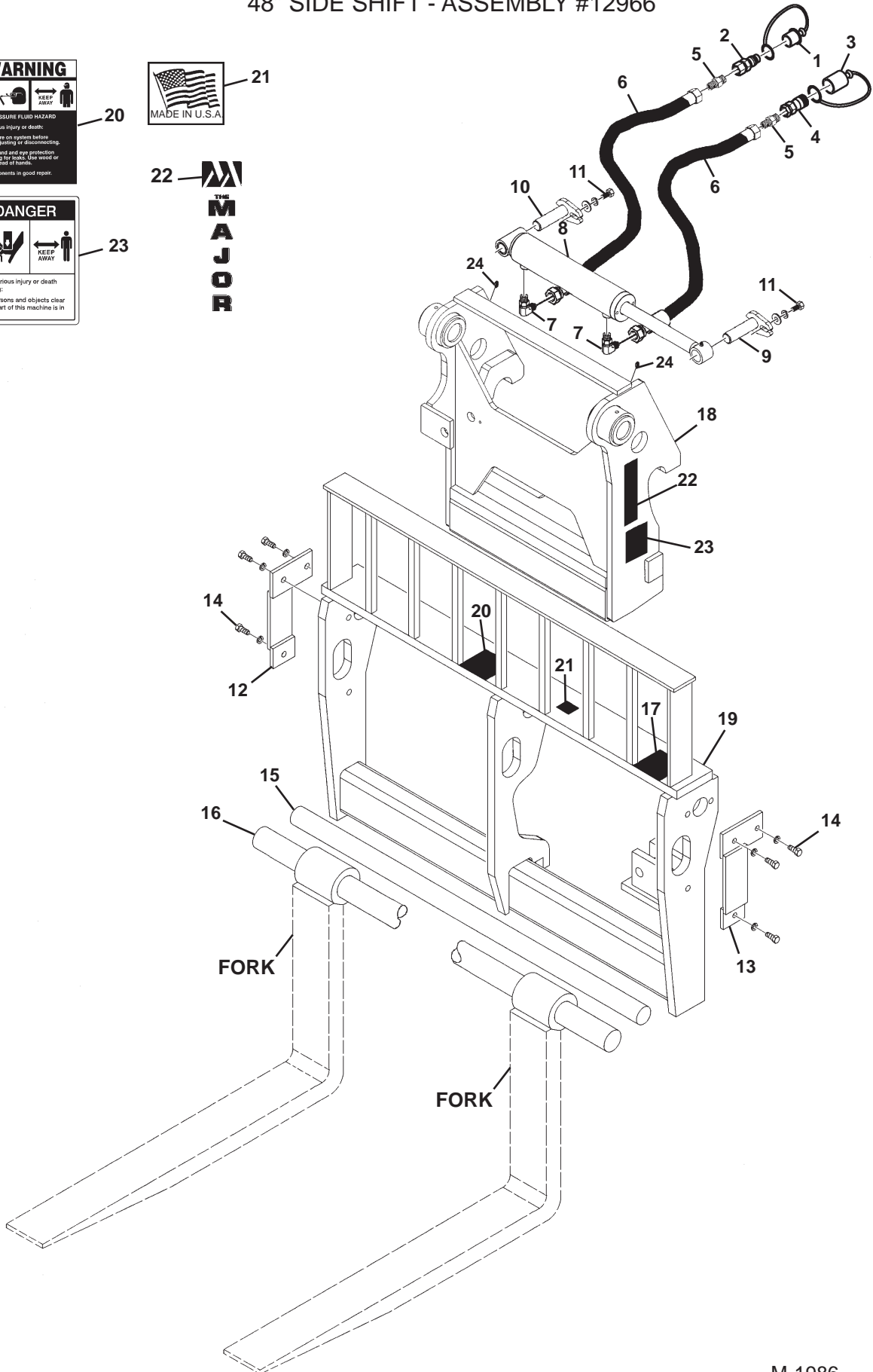

FORK CARRIAGE
48" SIDE SHIFT - ASSEMBLY #12966

<u>ITEM</u>	<u>QTY.</u>	<u>PART NO.</u>	<u>DESCRIPTION</u>
1	1	51753	Dust Cap
2	1	15109	Male Quick Coupler
3	1	51754	Dust Plug
4	1	15110	Female Quick Coupler
5	2	3125	Straight Connector, 6MJ-8MP
6	2	37839	Hose .38" X 50" 6FJX-6FJX
7	2	3434	90° Elbow, 6MBo-6MJ
8	1	88920	Cylinder Assembly
9	1	14071	Pin, 1.00" x 3.31"
10	1	100770	Pin, 1.00" x 4.00"
11	2	10023	.31" UNF x 1.00" Hex Capscrew
	2	1502	.31" Lock Washer
	2	1513	.31" Flat Washer
12	1	32547	Right Pin Retainer
13	1	32470	Left Pin Retainer
14	6	1090	.50" UNC x 1.50" Hex Capscrew
	6	1505	.50" Lock Washer
15	1	32493	Side Shift Pin, 2.00" x 47.75"
16	1	14262	Fork Pin, 60MM x 48.50"
17	1	-----	Serial Number Identification Tag Location
18	1	107318	Rear Frame
19	1	32469	Front Frame
20	1	40151	High Pressure Warning Decal
21	1	4338	Made in USA Decal
22	2	40501	Major Logo, Small
23	2	40149	Pinch Point Danger Decal
24	2	6133	Grease Zerk

***CONTACT YOUR DEALER FOR TINES AVAILABLE FOR YOUR ATTACHMENT.**

FORK CARRIAGE

60" SIDE SHIFT - ASSEMBLY #12703

WARNING

HIGH-PRESSURE FLUID HAZARD
To prevent serious injury or death:

- Relieve pressure on system before repairing or adjusting or disconnecting.
- Wear proper hand and eye protection when searching for leaks. Use wood or cardboard instead of hands.
- Keep all components in good repair.

DANGER

To prevent serious injury or death from pinching:

- Keep all persons and objects clear while any part of this machine is in motion.

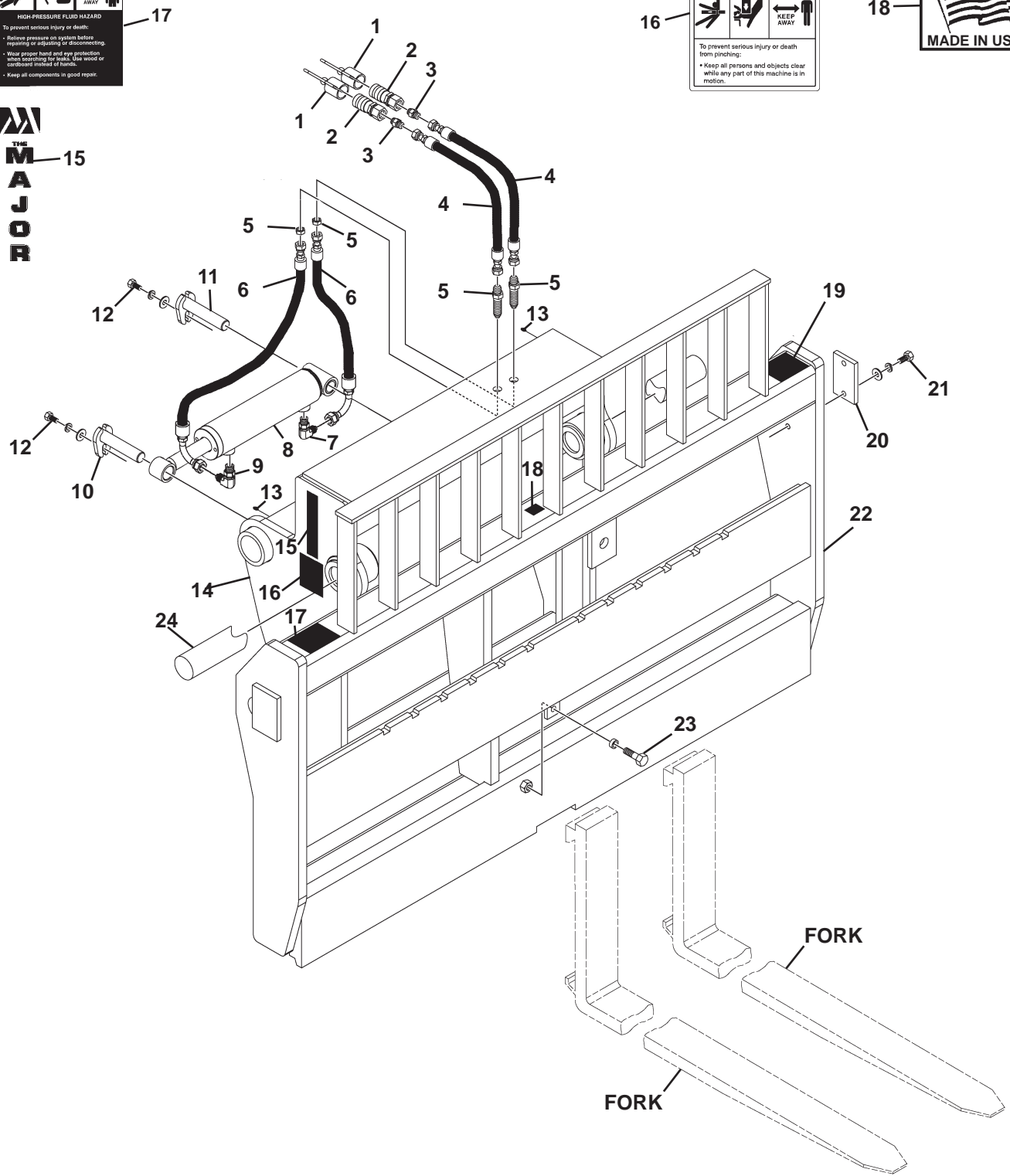

FORK CARRIAGE

60" SIDE SHIFT - ASSEMBLY #12703

<u>ITEM</u>	<u>QTY.</u>	<u>PART NO.</u>	<u>DESCRIPTION</u>
1	2	32548	Dust Cover
2	2	84928	Female Quick Coupler
3	2	3269	Straight Connector, 8MBo-6MJ
4	2	37887	Hose .38" X 64" 6FJX-6FJX
5	2	3297	Bulkhead Connector, 6MJ-6MJ
6	2	37862	Hose .38" X 23.25" 6FJX-6FJX90°
7	1	3434	90° Elbow, 6MBo-6MJ
8	1	88928	Cylinder Assembly
9	1	14067	90° Elbow, W/.027 Orifice, 6MBo-6MJ
10	1	12054	Pin, 1.00" x 3.75"
11	1	31990	Pin, 1.00" x 4.50"
12	2	1293	.38" UNF x 1.00" Hex Capscrew
	2	1503	.38" Lock Washer
	2	1514	.38" Flat Washer
13	2	9371	Grease Zerk
14	1	102014	Rear Frame
15	2	40501	Major Logo, Small
16	2	40149	Decal, Pinch Point
17	1	40151	High Pressure Warning Decal
18	1	4338	Made in USA Decal
19	1	-----	Serial Number Identification Tag Location
20	1	33541	Pin Retainer
21	2	1339	.50" UNF x 1.25" Hex Capscrew
	2	1505	.50" Lock Washer
	2	1516	.50" Flat Washer
22	1	102015	Front Frame
23	1	1089	.50" UNC x 1.25" Hex Capscrew
	1	86149	Spacer
	1	1228	.50" UNC Hex Nut
24	1	111597	Fork Pin, 2.00" x 61.00"

***CONTACT YOUR DEALER FOR TINES AVAILABLE FOR YOUR ATTACHMENT.**

FORK CARRIAGE

66" SIDE SHIFT - ASSEMBLY #12319

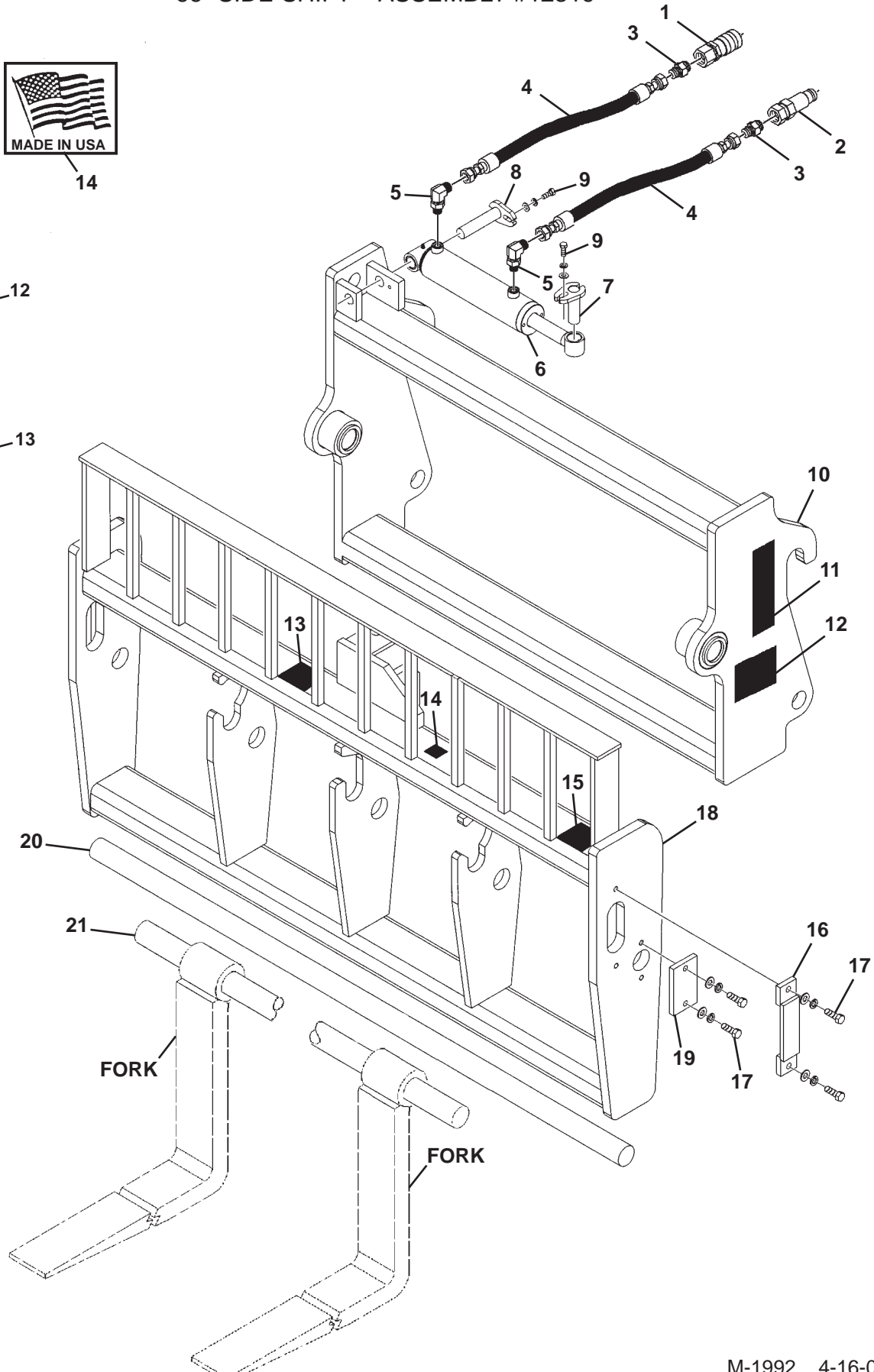

FORK CARRIAGE
66" SIDE SHIFT - ASSEMBLY #12319

<u>ITEM</u>	<u>QTY.</u>	<u>PART NO.</u>	<u>DESCRIPTION</u>
1	1	22518	Female Quick Coupler
2	1	22519	Male Quick Coupler
3	2	30201	Straight Connector, 12MBo-6MJ
4	2	37886	Hose .38" X 60" 6FJX-6FJX
5	2	3434	90° Elbow, 6MBo-6MJ
6	1	88928	Cylinder Assembly
7	1	14071	Pin, 1.00" x 3.31"
8	1	14070	Pin, 1.00" x 4.72"
9	2	1293	.38" UNF x 1.00" Hex Capscrew
	2	1503	.38" Lock Washer
	2	1514	.38" Flat Washer
10	1	33020	Rear Frame
11	2	40501	Major Logo, Small
12	2	40149	Decal, Pinch Point
13	1	40151	High Pressure Warning Decal
14	1	4338	Made in USA Decal
15	1	-----	Serial Number Identification Tag Location
16	1	14002	Fork Pin Retainer
17	4	1339	.50" UNF x 1.25" Hex Capscrew
	4	1505	.50" Lock Washer
	4	1516	.50" Flat Washer
18	1	33011	Front Frame
19	1	14606	Side Shift Pin Retainer
20	1	33027	Side Shift Pin, 2.00" x 66.00"
21	1	33199	Fork Pin, 2.00" x 66.75"

***CONTACT YOUR DEALER FOR TINES AVAILABLE FOR YOUR ATTACHMENT.**

FORK CARRIAGE

74" SIDE SHIFT - ASSEMBLY #11510



WARNING

HIGH-PRESSURE FLUID HAZARD
To prevent serious injury or death:

- Relieve pressure on system before repairing or adjusting or disconnecting.
- Wear proper hand and eye protection when searching for leaks. Use wood or cardboard instead of hands.
- Keep all components in good repair.

DANGER

To prevent serious injury or death from pinching:

- Keep all persons and objects clear while any part of this machine is in motion.

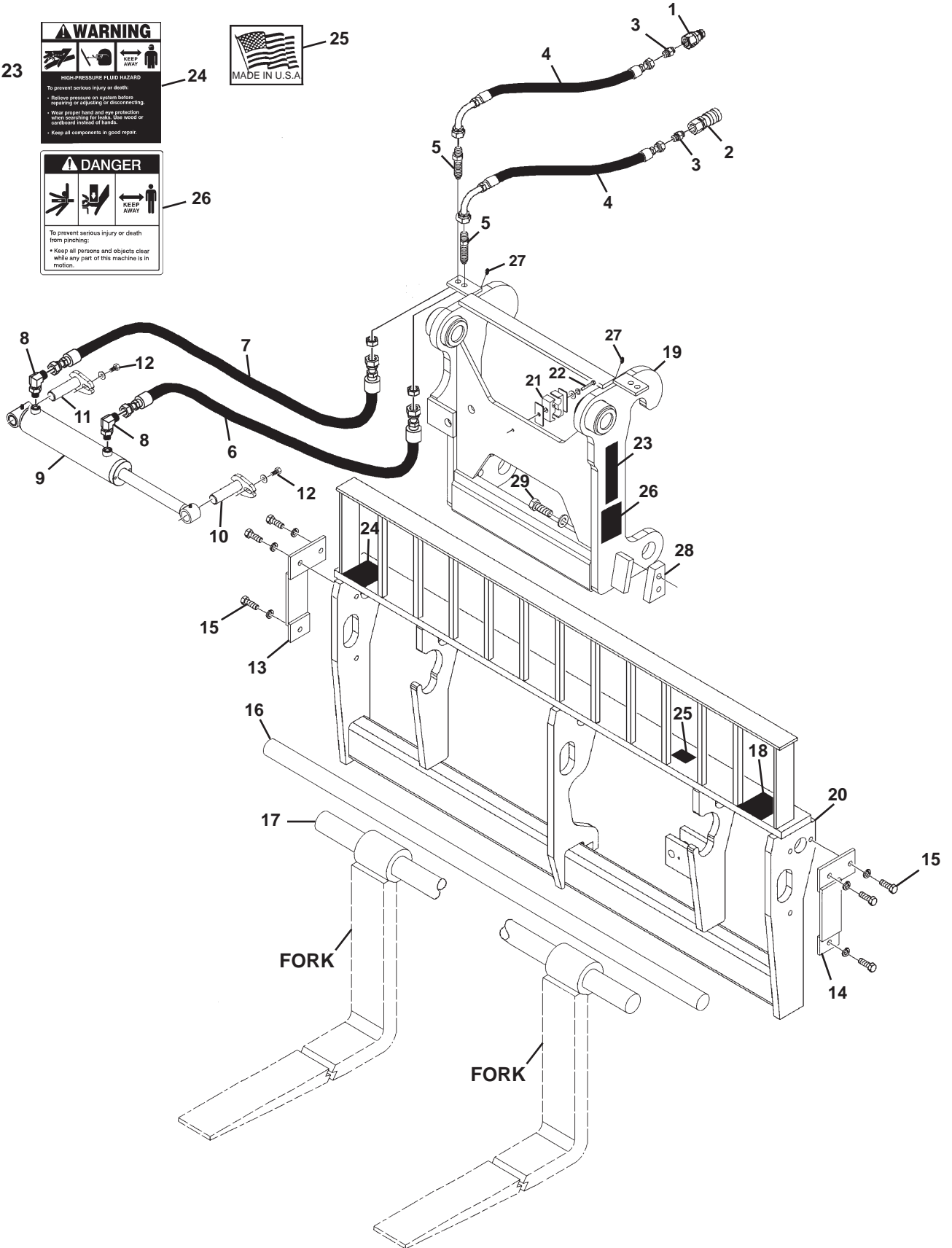

FORK CARRIAGE

74" SIDE SHIFT - ASSEMBLY #11510

<u>ITEM</u>	<u>QTY.</u>	<u>PART NO.</u>	<u>DESCRIPTION</u>
1	1	22519	Male Quick Coupler
2	1	22518	Female Quick Coupler
3	2	30201	Straight Connector, 12MBo-6MJ
4	2	37893	Hose .38" X 40" 6FJX-6FJX90°
5	2	3297	Bulkhead Straight Connector, 6MJ-6MJ
6	1	37838	Hose .38" X 28" 6FJX-6FJX
7	1	37492	Hose .38" X 40" 6FJX-6FJX
8	2	3434	90° Elbow, 6MBo-6MJ
9	1	88920	Cylinder Assembly
10	1	14071	Pin, 1.00" x 3.31"
11	1	100770	Pin, 1.00" x 4.00"
12	2	10023	.31" UNF x 1.00" Hex Capscrew
	2	1513	.31" Flat Washer
13	1	32547	Right Pin Retainer
14	1	32470	Left Pin Retainer
15	6	1090	.50" UNC x 1.50" Hex Capscrew
	6	1505	.50" Lock Washer
16	1	14780	Side Shift Pin, 2.00" x 74.25"
17	1	14602	Fork Pin, 60MM x 74.75"
18	1	-----	Serial Number Identification Tag Location
19	1	32468	Rear Frame
20	1	15007	Front Frame
21	1	81358	Hose Clamp
22	1	10023	.31" UNF x 1.00" Hex Capscrew
	1	1513	.31" Flat Washer
23	2	40501	Major Logo, Small
24	1	40151	High Pressure Warning Decal
25	1	4338	Made in USA Decal
26	2	40149	Pinch Point Danger Decal
27	2	6133	Grease Zerk
28	2	14228	Stop Block
29	4	10012	.75" UNC x 2.25" Hex Capscrew, Grade 8
	4	1507	.75" Lock Washer

***CONTACT YOUR DEALER FOR TINES AVAILABLE FOR YOUR ATTACHMENT.**

FORK CARRIAGE

74" SIDE SHIFT - ASSEMBLY #12965

WARNING

HIGH PRESSURE FLUID HAZARD

To prevent serious injury or death:

- Relieve pressure on system before repairing or adjusting or disconnecting.
- Wear proper hand and eye protection when searching for leaks. Use wood or cardboard instead of hands.
- Keep all components in good repair.



DANGER

To prevent serious injury or death from pinching:

- Keep all persons and objects clear while any part of this machine is in motion.

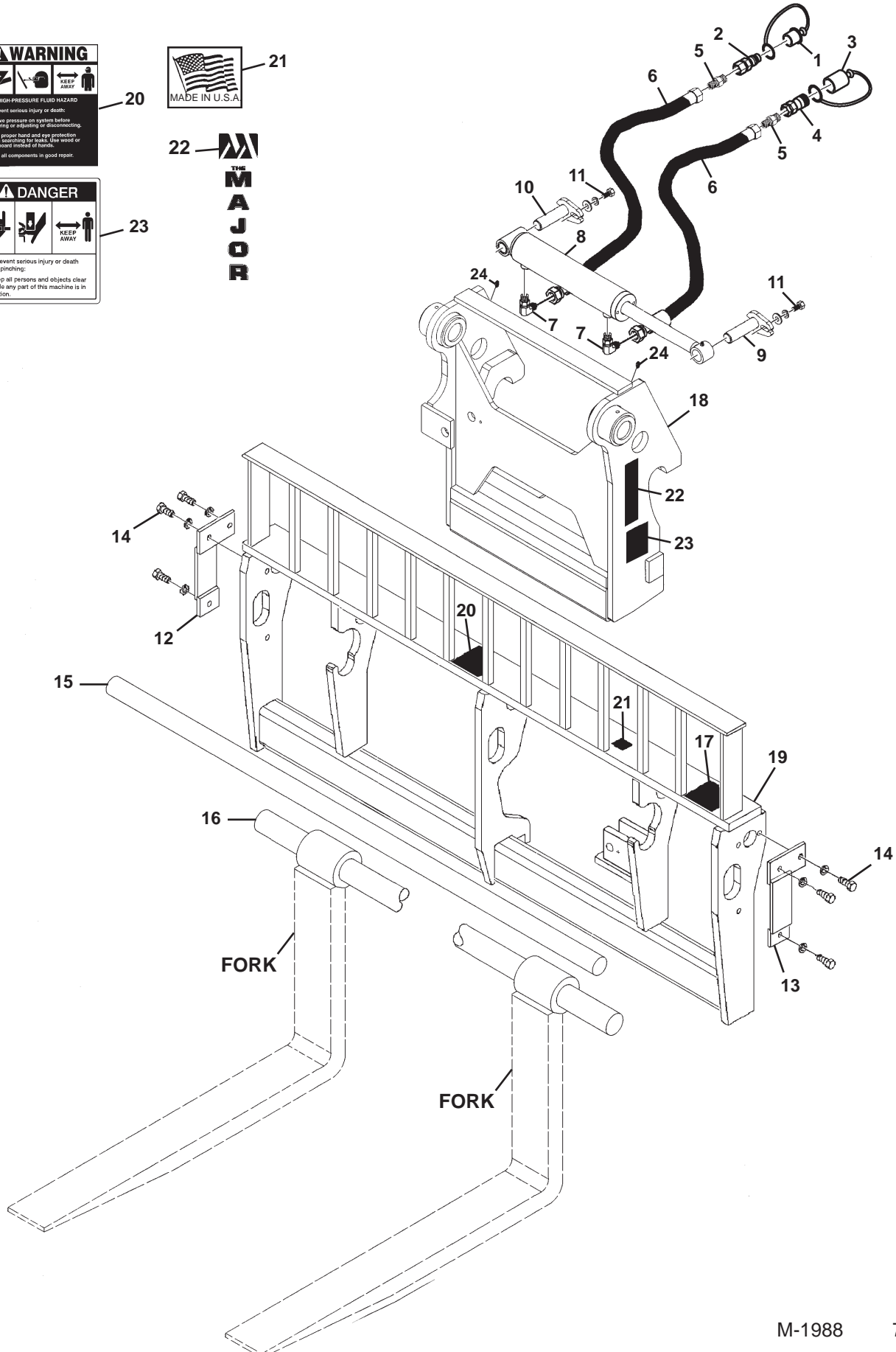

FORK CARRIAGE
74" SIDE SHIFT - ASSEMBLY #12965

<u>ITEM</u>	<u>QTY.</u>	<u>PART NO.</u>	<u>DESCRIPTION</u>
1	1	51753	Dust Cap
2	1	15109	Male Quick Coupler
3	1	51754	Dust Plug
4	1	15110	Female Quick Coupler
5	2	3125	Straight Connector, 6MJ-8MP
6	2	37839	Hose .38" X 50" 6FJX-6FJX
7	2	3434	90° Elbow, 6MBo-6MJ
8	1	88920	Cylinder Assembly
9	1	14071	Pin, 1.00" x 3.31"
10	1	100770	Pin, 1.00" x 4.00"
11	2	10023	.31" UNF x 1.00" Hex Capscrew
	2	1502	.31" Lock Washer
	2	1513	.31" Flat Washer
12	1	32547	Right Pin Retainer
13	1	32470	Left Pin Retainer
14	6	1090	.50" UNC x 1.50" Hex Capscrew
	6	1505	.50" Lock Washer
15	1	14780	Side Shift Pin, 2.00" x 74.25"
16	1	14602	Fork Pin, 60MM x 74.75"
17	1	-----	Serial Number Identification Tag Location
18	1	107318	Rear Frame
19	1	15007	Front Frame
20	1	40151	High Pressure Warning Decal
21	1	4338	Made in USA Decal
22	2	40501	Major Logo, Small
23	2	40149	Pinch Point Danger Decal
24	2	6133	Grease Zerk

***CONTACT YOUR DEALER FOR TINES AVAILABLE FOR YOUR ATTACHMENT.**

CYLINDER ASSEMBLY

ASSEMBLY #88920

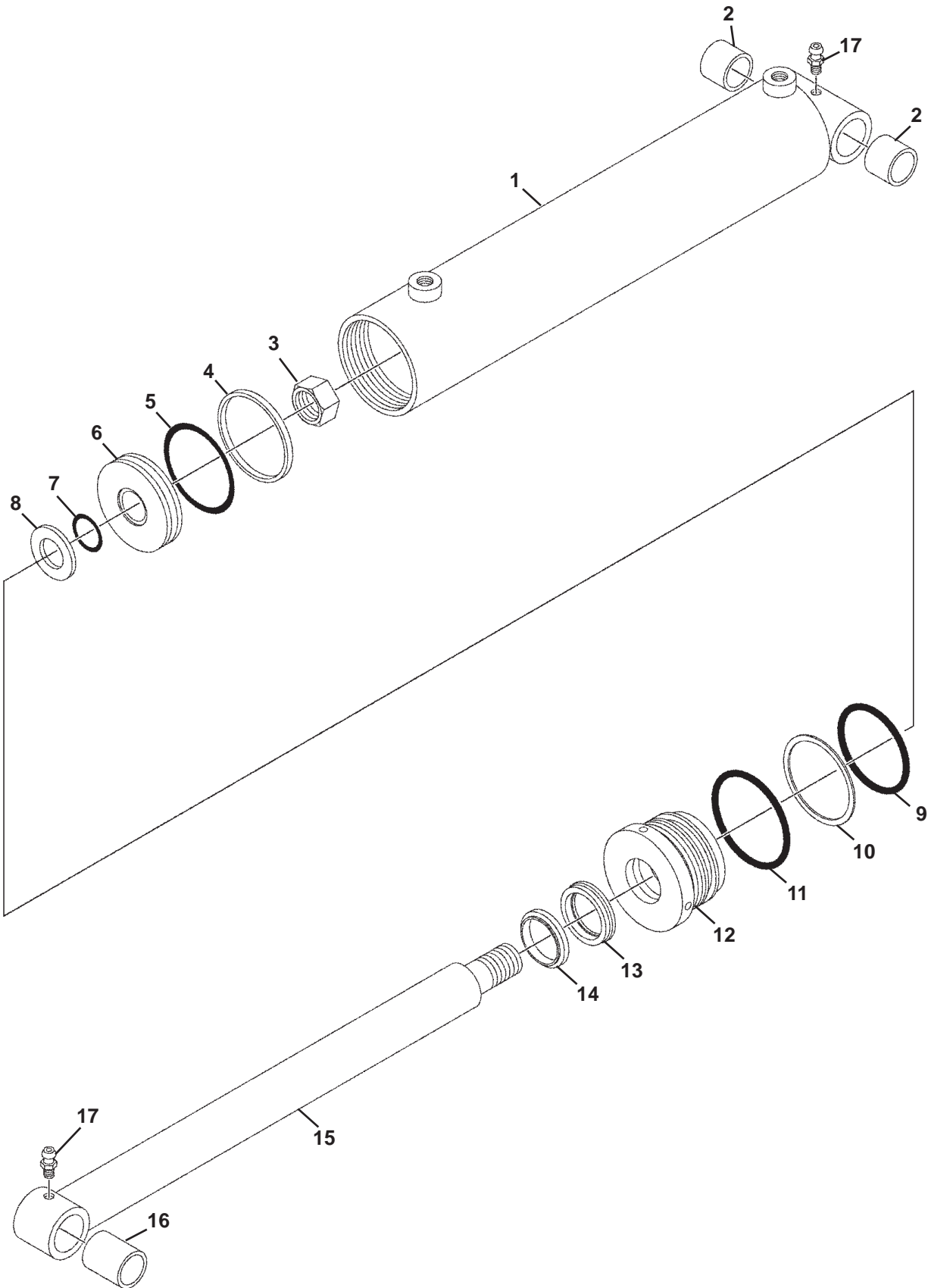

CYLINDER ASSEMBLY

ASSEMBLY #88920

<u>ITEM</u>	<u>QTY.</u>	<u>PART NO.</u>	<u>DESCRIPTION</u>
1	1	89112	Cylinder Tube, With Valve
2	2	88919	Bronze Bushing
3	1	1483	Hex Nut
4	1	4644*	Piston Ring
5	1	4645*	O-Ring
6	1	50252	Piston
7	1	4641*	O-Ring
8	1	5421	Washer
9	1	4509*	O-Ring
10	1	4510*	Back-Up Washer
11	1	45250*	O-Ring
12	1	77458	Cylinder Gland
13	1	45219*	Poly-Pak Seal
14	1	45389*	Rod Wiper
15	1	88915	Piston Rod
16	1	88918	Bronze Bushing
17	1	6616	Grease Zerk

NOTE: Seal Kit #45617 includes all parts marked with an asterisk (*). Parts are not sold separately.

CYLINDER ASSEMBLY

ASSEMBLY #88928

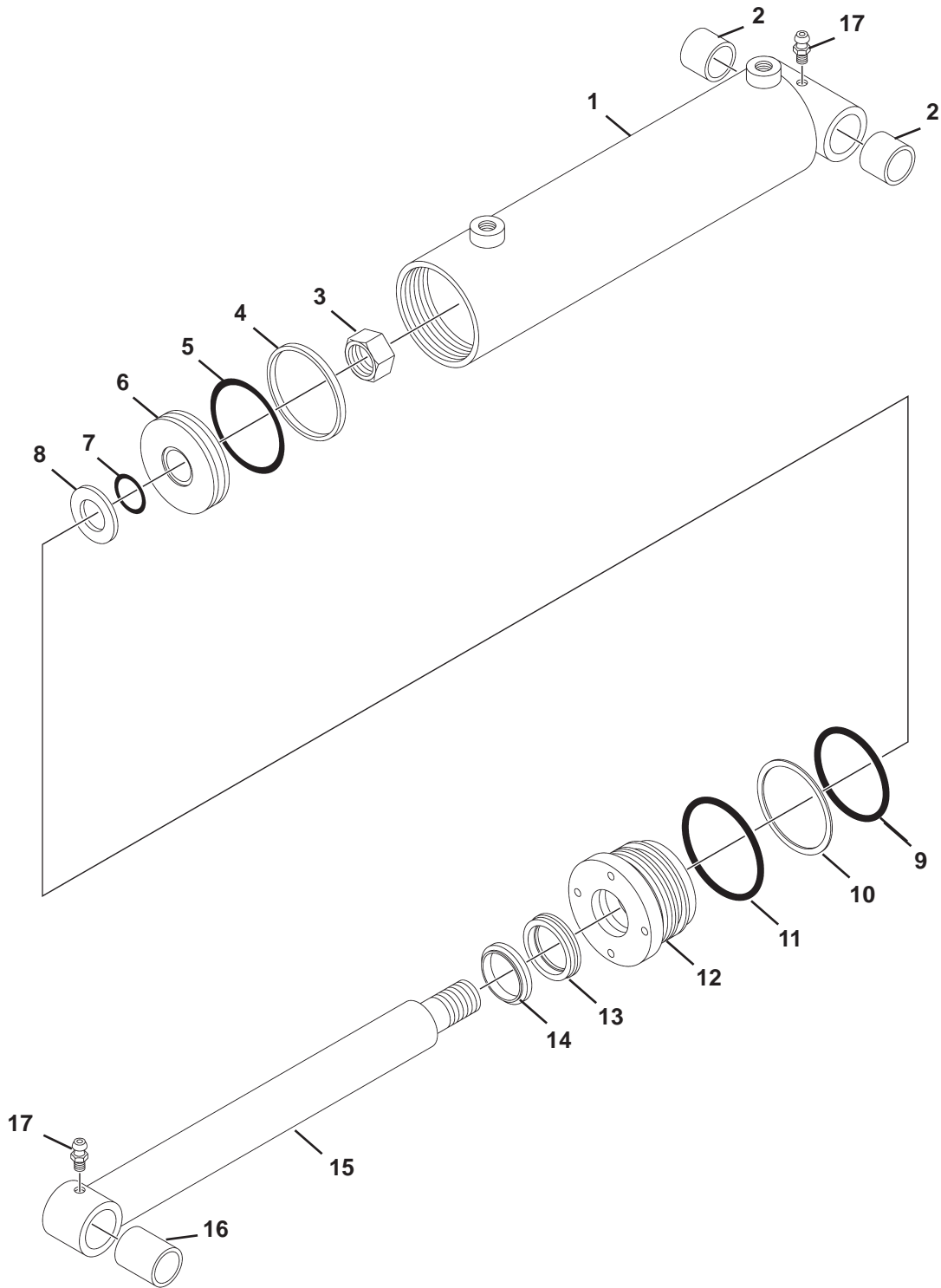

CYLINDER ASSEMBLY

ASSEMBLY #88928

<u>ITEM</u>	<u>QTY.</u>	<u>PART NO.</u>	<u>DESCRIPTION</u>
1	1	88926	Cylinder Tube
2	2	88919	Bronze Bushing
3	1	1483	Hex Nut
4	1	4644*	Piston Ring
5	1	4645*	O-Ring
6	1	50252	Piston
7	1	4641*	O-Ring
8	1	5421	Washer
9	1	4509*	O-Ring
10	1	4510*	Back-Up Washer
11	1	45250*	O-Ring
12	1	77458	Cylinder Gland
13	1	45219*	Poly-Pak Seal
14	1	45389*	Rod Wiper
15	1	88927	Cylinder Rod
16	1	88918	Bronze Bushing
17	2	6616	Grease Zerk

NOTE: Seal Kit #45617 includes all parts marked with an asterisk (*). Parts are not sold separately.